



---

## **ELECTRICAL CONTROL PANEL SCHEMATICS**

- **KROFTA PLC CONTROL PANEL**
- **KROFTA MOTOR CONTROL PANEL**



**Krofta Technologies LLC**  
PO Box 7 401 South Street Dalton MA 01227  
Tel: 413.236.5634 Fax: 413.236.6917 info@krofta.com

# AUMSVILLE WWTP

AUMSVILLE, OR

KROFTA PROJECT NUMBER: 25-K01  
ELECTRICAL PROJECT NUMBER: 56003EN-25

RELEASED FOR: REVIEW			
REV.	DATE	BY	REVISION DESCRIPTION
A	04/15/2025	CWF	FOR REVIEW
A.1	05/29/2025	CWF	UPDATED PER CUSTOMER COMMENTS

FILENAME	SUB	SH	DESCRIPTION-1	DESCRIPTION-2	CR
56003EN25_0A01	A	1	COVER SHEET		A.1
56003EN25_0A02	A	2	INDEX PAGE		A.1
56003EN25_0A03	A	3	DEFINITIONS PAGE		A.1
56003EN25_0A04	A	4	ECP-DAF-3001	BILL OF MATERIALS	A.1
56003EN25_0A05	A	5	MCP-DAF-3002	BILL OF MATERIALS	A.1
56003EN25_0B01	B	1	ECP-DAF-3001	EXTERNAL LAYOUT	A.1
56003EN25_0B02	B	2	ECP-DAF-3001	INTERNAL LAYOUT	A.1
56003EN25_0B03	B	3	MCP-DAF-3002	EXTERNAL LAYOUT	A.1
56003EN25_0B04	B	4	MCP-DAF-3002	INTERNAL LAYOUT	A.1
56003EN25_0B05	B	5	ECP-DAF-3001	PLC AND I/O TERMINALS DETAILS	A.1
56003EN25_0B06	B	6	ECP-DAF-3001	POWER DISTRIBUTION & NETWORK SWITCH DETAILS	A.1
56003EN25_0B07	B	7	MCP-DAF-3002	480VAC POWER DISTRIBUTION DETAILS	A.1
56003EN25_0B08	B	8	MCP-DAF-3002	SPARE SHEET	A.1
56003EN25_0B09	B	9	NETWORK LAYOUT		A.1
56003EN25_0C01	C	1	MCP-DAF-3002	3 PHASE WIRING	A.1
56003EN25_0C02	C	2	MCP-DAF-3002	3 PHASE WIRING	A.1
56003EN25_0C03	C	3	MCP-DAF-3002	3 PHASE WIRING	A.1
56003EN25_0D01	D	1	ECP-DAF-3001	120 VAC CONTROL POWER	A.1
56003EN25_0E01	E	1	CONTROL WIRING		A.1
56003EN25_0E02	E	2	CONTROL WIRING		A.1
56003EN25_0E03	E	3	E-STOP SAFETY CIRCUIT	DRIVE SAFE OFF	A.1
56003EN25_0F01	F	1	ECP-DAF-3001	ANALOG INPUT	A.1
56003EN25_0F02	F	2	ECP-DAF-3001	ANALOG OUTPUT	A.1
56003EN25_0G01	G	1	ECP-DAF-3001	DIGITAL INPUTS	A.1
56003EN25_0G02	G	2	ECP-DAF-3001	DIGITAL OUTPUTS	A.1
56003EN25_0H01	H	1	CHEMICAL PUMPS		A.1



**Krofta Technologies LLC**  
 P.O. Box 7, 401 South Street, Dalton MA 01227  
 Tel: 413.236.5634 Fax: 413.236.6917 info@krofta.com

**AUMSVILLE WWTP**  
 AUMSVILLE, OR

RELEASED FOR: REVIEW

REV.	DATE	BY	REVISION DESCRIPTION
A	04/15/2025	CWF	FOR REVIEW
A.1	05/29/2025	CWF	UPDATED PER CUSTOMER COMMENTS

INDEX PAGE

SECTION: DWN BY: CFW  
 DRAWING NUM: 56003EN25\_0A02

CHK'D BY: DATE DWN: 04/15/2025  
 SUB SEC: A

PROJECT NUM: 56003EN-25  
 SHEET: 2 OF 5  
 REV: A.1

01  
02  
03  
04  
05  
06  
07  
08  
09  
10  
11  
12  
13  
14  
15  
16  
17  
18  
19  
20

### LINE NUMBERS

REPEATING TO EACH SHEET  
TO THE LEFT OF EACH SCHEMATIC COLUMN  
1-20 LADDER COLUMN 1 AND  
21-40 LADDER COLUMN 2  
ON EQUAL INTERVALS. (EXAMPLE TO LEFT)

### WIRE COLUMN / PAGE BREAK

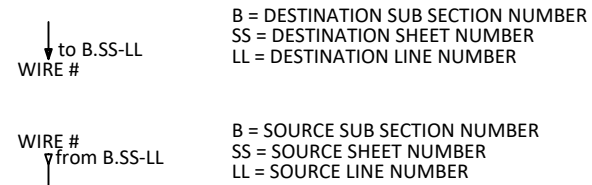

### WIRE NUMBERS

A:BB/CC      A = TYPE OF CARD (I FOR INPUT, O FOR OUTPUT)  
                  BB = MODULE SLOT NUMBER  
                  CC = INPUT/OUTPUT NUMBER

A.BBCC.D      A = SUB SECTION NUMBER  
                  BB = SHEET NUMBER  
                  CC = LINE NUMBER  
                  D = LINE REFERENCE

### CABLE MARKERS

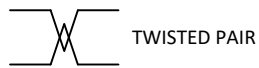
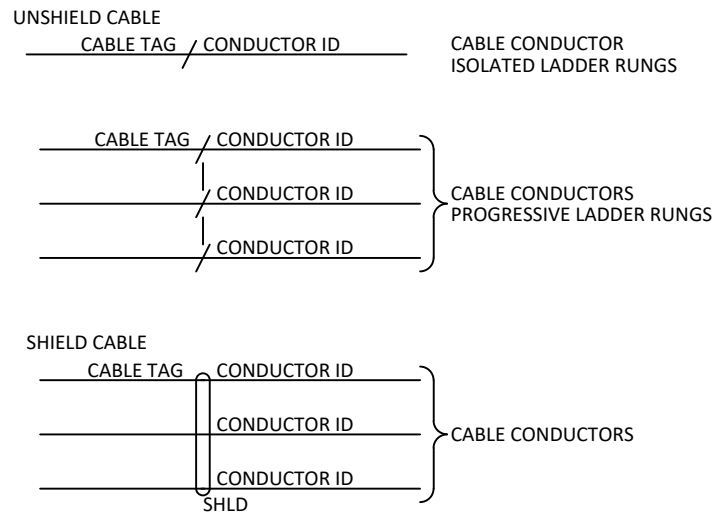

### CABLE COLOR ABBREVIATIONS

- BLK — BLACK
  - BLU — BLUE
  - BRN — BROWN
  - CYN — CYAN
  - GRY — GRAY
  - GRN — GREEN
  - ORG — ORANGE
  - PUR — PURPLE
  - RED — RED
  - VIO — VIOLET
  - WHT — WHITE
  - YEL — YELLOW
- BLK-WHT BLACK WIRE, WHITE TRACER

### SOCKET & PLUG CONNECTOR

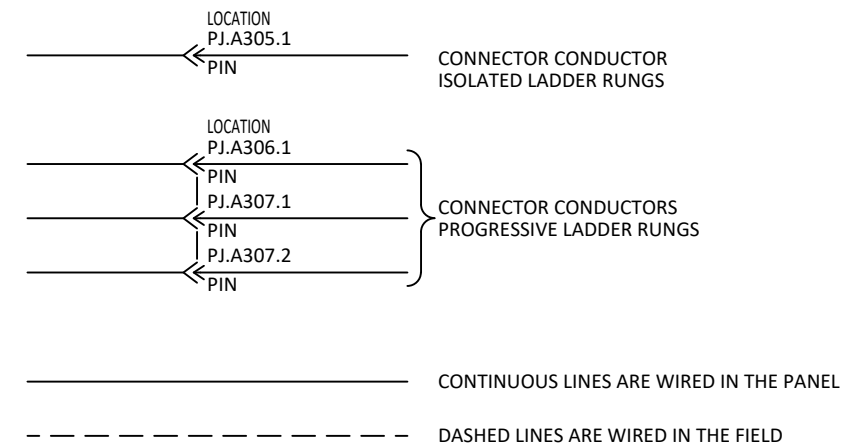

### FOOTNOTE DEFINITIONS

- 00.A3/1.1 SHIELD ISOLATED
- 00.A3/2.1 FLOW METER, REMOTE SIGNAL CABLE  
TRANSMITTER END, INNER SHIELD TERMINATED  
OUTER SHIELD ISOLATED  
FLOW HEAD END, INNER SHIELD TERMINATED  
OUTER SHIELD TERMINATED



**Krofta Technologies LLC**  
PO Box 7, 401 South Street, Dalton MA 01227  
Tel: 413.236.5634 Fax: 413.236.6917 info@krofta.com

**AUMSVILLE WWTP**  
AUMSVILLE, OR

REV.	DATE	BY	REVISION DESCRIPTION
A	04/15/2025	CWF	FOR REVIEW
A.1	05/29/2025	CWF	UPDATED PER CUSTOMER COMMENTS

SECTION:	DWN BY:	CHK'D BY:	DATE DWN:	PROJECT NUM:
DRAWING NUM:	CWF	A	04/15/2025	56003EN-25
56003EN25_0A03			SHEET:	OF:
			3	5
			REV:	A.1

DEFINITIONS PAGE

RELEASED FOR: REVIEW

ECP-DAF-3001 BILL OF MATERIALS (BOM)				
ITEM	QTY	CATALOG	MFG	DESCRIPTION
1	1	SCE-72XM4018	SCE	FREE-STANDING TYPE 12 SINGLE-DOOR ENCLOSURE
2	1	SCE-DCP	SCE	DISCONNECT COVER PLATE
3	1	SCE-64P37	SCE	60 X 33.75, SUB-PANEL, PAINTED WHITE
8	1	194R-PY	AB	RED/YELLOW PADLOCKABLE HANDLE
9	1	194U-S1	AB	S SHAFT 12 INCH
10	1	194U-A60-1753	AB	IEC LOAD SWITCH, OPEN - BASE / DIN RAIL, CHANGEOVER 1-0-2 90°, 60A, 3 POLES
11	1	194U-N1	AB	NFPA HANDLE
14	1	4983-DS120-401	AB	SURGE PROTECTION, 35mm DIN RAIL MOUNT, UL 1449 , 120V, 40KA, 1 POLE
17	1	SCE-SLMS	SCE	ENCLOSURE LIGHT, 14.07" LONG, 400 LUMENS, LED, MOTION SENSOR
18	1	SCE-SLCC	SCE	CABLE FOR ENCLOSURE LIGHT
29	16	GMC-63-R	BUSSMANN	FERRULE FUSE (5mm) 63mA, BUSSMANN, MEDIUM TIME DELAY, 250VAC, 63mA, GLASS FUSE, 5x20mm
30	32	GMC-2-R	BUSSMANN	FERRULE FUSE (5mm) 3A, BUSSMANN, MEDIUM TIME DELAY, 250VAC, 2A, GLASS FUSE, 5x20mm
37	2	LP-CC-25	BUSSMAN	FUSE, CLASS CC, 25A, 600VAC, 200KAIC
38	1	1492-FB2C30	AB	FUSE HOLDER, CLASS CC FUSES, 2-POLE, FINGERSAFE
44	2	1489-M1C150	AB	BULLETIN 1489 MINIATURE CIRCUIT BREAKER, 1 POLE, TRIP CURVE C, 15 AMP, UL/CSA 277V AC, 48V DC
45	1	1489-M1C010	AB	BULLETIN 1489 MINIATURE CIRCUIT BREAKER, 1 POLE, TRIP CURVE C, 1 AMP, UL/CSA 277V AC, 48V DC
46	1	1489-M1D100	AB	BULLETIN 1489 MINIATURE CIRCUIT BREAKER, 1 POLE, TRIP CURVE D, 10 AMP, UL/CSA 277V AC, 48V DC
47	1	1489-M1C400	AB	BULLETIN 1489 MINIATURE CIRCUIT BREAKER, 1 POLE, TRIP CURVE C, 40 AMP, UL/CSA 277V AC, 48V DC
48	3	1489-M1C050	AB	BULLETIN 1489 MINIATURE CIRCUIT BREAKER, 1 POLE, TRIP CURVE C, 5 AMP, UL/CSA 277V AC, 48V DC
49	1	1115661	PHOENIX CONTACT	POWER FEED MODULE WITH STATUS OUTPUT AND RESET INPUT.
50	1	1110989	PHOENIX CONTACT	BUSBAR FOR THE CAPAROC SYSTEM WITH 20 SLOTS. FOR INSTALLATION ON A DIN RAIL.
51	2	1115657	PHOENIX CONTACT	4-CHANNEL ELECTRONIC CIRCUIT BREAKER MODULE. NOMINAL CURRENT ADJUSTABLE FROM 1A TO 4A VIA LED BUTTON. NEC CLASS 2
52	2	1115658	PHOENIX CONTACT	4-CHANNEL ELECTRONIC CIRCUIT BREAKER MODULE. NOMINAL CURRENT ADJUSTABLE FROM 1A TO 10A VIA LED BUTTON.
53	4	1110987	PHOENIX CONTACT	POTENTIAL DISTRIBUTOR WITH PUSH-IN CONNECTIONS FOR DIRECTLY CONNECTING THE 0 V RETURN CONDUCTOR IN THE CAPAROC SYSTEM.
75	1	1159038	PHOENIX CONTACT	PRIMARY-SWITCHED TRIO3 POWER SUPPLY WITH PUSH-IN CONNECTION, DIN RAIL, INPUT: SINGLE-PHASE, OUTPUT: 24 V DC/10 A
76	1	2907067	PHOENIX CONTACT	QUINT4 DC UPS MODULE, DIN RAIL, INPUT: 24VDC, OUTPUT: 24 V DC/10 A, USB PORT
77	1	1274118	PHOENIX CONTACT	QUINT4 DC UPS BATTERY, 24VDC, 7 AH
85	1	2711P-T9W22D9P	AB	PANELVIEW PLUS 7 PERFORMANCE TERMINAL, TOUCH SCREEN, 12 WXGA, WIDE ASPECT RATION COLOR, ETHERNET DLR, 24V DC
86	1	FLEXY205	EWON	MODULAR INDUSTRIAL M2M ROUTER AND DATA GATEWAY
88	1	P-P11R2-K4RF0	GRACE ENGINEERING	PROGRAMMING PORT, 5e ETHERNET, USB, GFCI W/ NO CIRCUIT BREAKER, UL TYPE 12
89	1	LNX-800A-T	ANTAIRA	8-PORT INDUSTRIAL UNMANAGED SWITCH, 10/100TX, EOT
95	1	1756-A10	AB	1756 CONTROL LOGIX RACK I/O, 10 SLOT CHASSIS
96	1	1756-PB50	AB	1756 CONTROL LOGIX POWER SUPPLY
97	1	1756-L81E	AB	1756 CONTROL LOGIX PROCESSORS LOGIX 5580, 3MB MEMORY
98	1	1756-IF8	AB	1756 CONTROL LOGIX PLC ANALOG INPUT MODULE
99	1	1756-OF8	AB	1756 CONTROL LOGIX PLC ANALOG OUTPUT MODULE
100	2	1756-IB16	AB	1756 CONTROL LOGIX PLC DIGITAL DC INPUT MODULE
101	2	1756-OW16I	AB	1756 CONTROL LOGIX PLC DIGITAL RELAY OUTPUT MODULE
102	3	1756-N2	AB	1756 CONTROL LOGIX SLOT FILLER CARD
103	3	1756-TBCH	AB	1756 TERMINAL BLOCK
104	3	1756-TBNH	AB	1756 TERMINAL BLOCK
105	4	1756-JMPR	AB	1756 JUMPER
110	5	700-HLT1Z24	AB	HL TYPE TERMINAL BLOCK RELAY, 24VDC, 6A, SPDT, ELECTROMECHANICAL RELAY OUTPUT, SCREW TERMINAL
111	1	DC 2BD0	WARRICK	CONDUCTIVE LEVEL CONTROL, 8 PIN, 10K OHMS, 10-SEC DELAY
112	1	700-HN100	AB	SCREW TERMINAL TUBE BASE SOCKET, GUARDED TERMINAL CONSTRUCTION
120	1	440R-S12R2	AB	GUARDMASTER SINGLE INPUT SAFETY RELAY (SI), 1 DUAL CHANNEL UNIVERSAL INPUT, 1 N.C. SOLID STATE AUXILIARY OUTPUT
121	3	700-HPS2Z24	AB	SAFETY CONTROL RELAY, 700-HP GENERAL PURPOSE PCB PIN STYLE RELAY, 8 A, 2 POLE, DPDT, 24V DC
	3	700-HN123	AB	SCREW TERMINAL MINIATURE SOCKET
122	3	700-ADL1R	AB	VARIATOR WITH LED SURGE SUPPRESSOR, 6-24VDC
130	2	1492-BSPJLD3N	AB	END BARRIER FOR 1492-JDG3N, GREY (STANDARD)
131	3	1492-J4-BL	AB	SCREW CONNECTION TERMINAL BLOCK; 1492-J
133	4	1492-J4-W	AB	SCREW CONNECTION TERMINAL BLOCK; 1492-J
134	6	1492-JG3	AB	SCREW CONNECTION TERMINAL BLOCK; 1492-J
135	2	1492-JG4	AB	SCREW CONNECTION TERMINAL BLOCK; GREEN/YELLOW; 20-10AWG, GFEEED-THROUGH GROUND BLOCK
136	49	1492-JD3-B	AB	SCREW CONNECTION TERMINAL BLOCK; 1492-J
138	9	1492-JDG3N	AB	TERMINAL BLOCK 1492, GRAY
139	32	1492-JD3FB	AB	TERMINAL BLOCK 1492, GRAY
140	16	1492-JDG3FB	AB	TERMINAL BLOCK 1492, GRAY
141	3	1492-WTF3	AB	TERMINAL BLOCK 1492, GRAY
143	5	1492-EBJD3-B	AB	END BARRIER, 1492-J, BLUE
144	4	1492-EBJD3FB	AB	END BARRIER, 1492-J, GREY
145	2	1492-EBTF3	AB	END BARRIER FOR 1492-WTF3, GREY (STANDARD)
146	1	1492-JT3M	AB	TERMINAL BLOCK 1492, GRAY
147	1	1492-EBJ3TM	AB	END BARRIER, 1492-J
148	35	1492-EAJ35	AB	1492 TERMINAL BLOCK ACCESSORIES, END ANCHOR, USED W/ STANDARD 35MM DIN RAIL
165	1	800FP-LMT44	AB	800F ILLUMINATED MUSHROOM OPERATORS, ILLUMINATED, TWIST TO RELEASE, 40MM, TYPE 4/4X/13, IP66, RED
	1	800F-X20D	AB	22.5mm PB NO LATCH, SCREW CONTACT BLOCK, 2 N.O. DOUBLE CIRCUIT
	1	800F-X02D	AB	22.5mm PB NO LATCH, SCREW CONTACT BLOCK, 2 N.C. DOUBLE CIRCUIT
	1	800F-ALP	AB	800F LATCH, PLASTIC LATCH
167	1	800F-15YSE112	AB	800F LEGEND PLATE, 60MM ROUND, 22.5MM OPENING
166	1	800FP-LF0	AB	800F MOMENTARY PUSH BUTTON - PLASTIC, ILLUMINATED, FLUSH, AMBER
	1	800F-N3W	AB	POWERBLOCK MODULE w LED
	1	800F-ALP	AB	800F MOUNTING LATCH
	1	800F-X10	AB	800F CONTACT BLOCK
170	1	800F-11WE186	AB	800F LEGEND PLATE, 30 X 40MM STD., 2 PIECE SNAP-IN, RESET, WHITE WITH BLACK LEGEND TEXT, 22.5MM OPENING
169	1	800FP-SM22	AB	SELECTOR SW - 2 POS MAINTAINED
	1	800F-X10	AB	800F CONTACT BLOCK
	1	800F-ALP	AB	800F MOUNTING LATCH
168	1	800F-11WE156	AB	LEGEND PLATE FOR 2 POS SELECTOR SW, MANUAL - AUTO
171	1	855PC-B24ME422	AB	PANEL MOUNT SOUNDER WITH LED, 855PC SERIES
172	1	855PB-B24ME522	AB	PANEL MOUNT SELECTABLE STEADY OR FLASHING LED, 855PB SERIES



**Krofta Technologies LLC**  
 P.O. Box 7  
 401 South Street  
 Dalton MA 01227  
 Tel: 413.236.5634 Fax: 413.236.6917 info@krofta.com

**AUMSVILLE WWTP**  
 AUMSVILLE, OR

**RELEASED FOR: REVIEW**

REV.	DATE	BY	REVISION DESCRIPTION
A	04/15/2025	CWF	FOR REVIEW
A.1	05/29/2025	CWF	UPDATED PER CUSTOMER COMMENTS

SECTION:	DWN BY:	CHK'D BY:	DATE DWN:	PROJECT NUM:
DRAWING NUM: 56003EN25 0A04	CWF		04/15/2025	56003EN-25
		SUB SEC:	SHEET:	OF:
		A	4	5
				REV: A.1

ECP-DAF-3001  
 BILL OF MATERIALS

MCP-DAF-3002 BILL OF MATERIALS (BOM)				
ITEM	QTY	CATALOG	MFG	DESCRIPTION
1	1	SCE-72XM4018	SCE	FREE-STANDING TYPE 12 SINGLE-DOOR ENCLOSURE
2	1	SCE-DCP	SCE	DISCONNECT COVER PLATE
3	1	SCE-64P37	SCE	60 X 33.75, SUB-PANEL, PAINTED WHITE
4	1	140G-G2C3-C40	AB	140G - MOLDED CASE CIRCUIT BREAKER, G FRAME, 25 KA, T/M - THERMAL MAGNETIC, 40 AMPS
5	1	140G-G-TLC13	AB	FRAME-G, TERMINAL LUG, QTY 3, FCCU 1X14-1/0AWG
6	1	140G-G-MTL63	AB	FRAME-G, MULTI TERMINAL LUG, QTY 3, 6X14-2AWG
7	1	140G-G-NVM21R	AB	140G PRODUCT HANDLE ACCESSORIES/OPERATING MECHANISMS, 140G ROTARY , ROTARY HANDLE WITH NFPA79 HANDLE ,21" , RED/YELLOW
12	1	VS-AVT-C08-L10	PANDUIT	ABSENCE OF VOLTAGE TESTER
13	1	813S-V3-480V	AB	THREE-PHASE VOLTAGE MONITORING RELAY, 440...480V AC (TYPE V3),
16	1	599-GR1	AB	GROUND LUG KIT, 30A...100A
17	1	SCE-SLMS	SCE	ENCLOSURE LIGHT, 14.07" LONG, 400 LUMENS, LED, MOTION SENSOR
18	1	SCE-SLCC	SCE	CABLE FOR ENCLOSURE LIGHT
20	1	SCE-N12FA66LG	SCE	FAN ASSEMBLY, 6", 115VAC, 0.36AM RAL 7035, UL TYPE 12
21	1	SCE-N12FGA66LG	SCE	FAN GRILLE ASSEMBLY, RAL 7035, UL TYPE 12
26	1	1492-FB3C30-L	AB	3 POLE FUSE BLOCK - CLASS CC
27	3	1492-FB3J30-L	AB	3 POLE FUSE BLOCK - CLASS J
31	3	FNQ-R-2	BUSSMANN	FUSE - CLASS CC, 2AMPS
33	3	LPJ-30SP	BUSSMANN	DUAL ELEMENT FUSE - CLASS J, 30AMPS
35	3	JJS-6	BUSSMANN	FUSE - CLASS T
36	3	JJS-15	BUSSMANN	FUSE - CLASS T
60	1	100-C16EJ10	AB	100-C CONTACTOR, 3-POLE
62	1	193-1EFDB	AB	IEC E100 SOLID-STATE OVERLOAD RELAY, 3-PHASE, SCREW TYPE CONTROL TERMINALS
64	1	20G21RD3P4JA0NNNNN	AB	AC Drive, W/ Dual Embedded EtherNet/IP, Forced Air, AC Input W/Precharge, Incl. DC Term., 480 VAC, 3 PH, CM Jumper Installed, DB Transistor
65	1	20G21RD8P0JA0NNNNN	AB	AC Drive, W/ Dual Embedded EtherNet/IP, Forced Air, AC Input W/Precharge, Incl. DC Term., 480 VAC, 3 PH, CM Jumper Installed, DB Transistor
66	2	20-750-S	AB	POWERFLEX 750 AC DRIVE, SAFE TORQUE OFF MODULE
131	9	1492-J4-BL	AB	SCREW CONNECTION TERMINAL BLOCK; 1492-J
132	2	1492-J4-G	AB	SCREW CONNECTION TERMINAL BLOCK; 1492-J
135	3	1492-JG4	AB	SCREW CONNECTION TERMINAL BLOCK; GREEN/YELLOW; 20-10AWG, GFEEED-THROUGH GROUND BLOCK
137	7	1492-JD3-Y	AB	SCREW CONNECTION TERMINAL BLOCK; 1492-J
141	8	1492-WTF3	AB	TERMINAL BLOCK 1492, GRAY
142	3	1492-EBJD3	AB	END BARRIER; 1492-J, GREY
145	1	1492-EBTF3	AB	END BARRIER FOR 1492-WTF3, GREY (STANDARD)
148	17	1492-EAJ35	AB	1492 TERMINAL BLOCK ACCESSORIES, END ANCHOR, USED W/ STANDARD 35MM DIN RAIL
149	1	1492-JD3	AB	TERMINAL BLOCK, 2 TIER, GREY



**Krofta Technologies LLC**  
 401 South Street  
 Dalton MA 01227  
 Tel: 413.236.5634 Fax: 413.236.6917 info@krofta.com

**AUMSVILLE WWTP**  
 AUMSVILLE, OR

RELEASED FOR: REVIEW

REV.	DATE	BY	REVISION DESCRIPTION
A	04/15/2025	CWF	FOR REVIEW
A.1	05/29/2025	CWF	UPDATED PER CUSTOMER COMMENTS

MCP-DAF-3002  
 BILL OF MATERIALS

SECTION:	DWN BY:	CHK'D BY:	DATE DWN:	PROJECT NUM:
DRAWING NUM: 56003EN25 0A05	CFW		04/15/2025	56003EN-25
			SHEET:	OF:
			5	5
			REV:	A.1

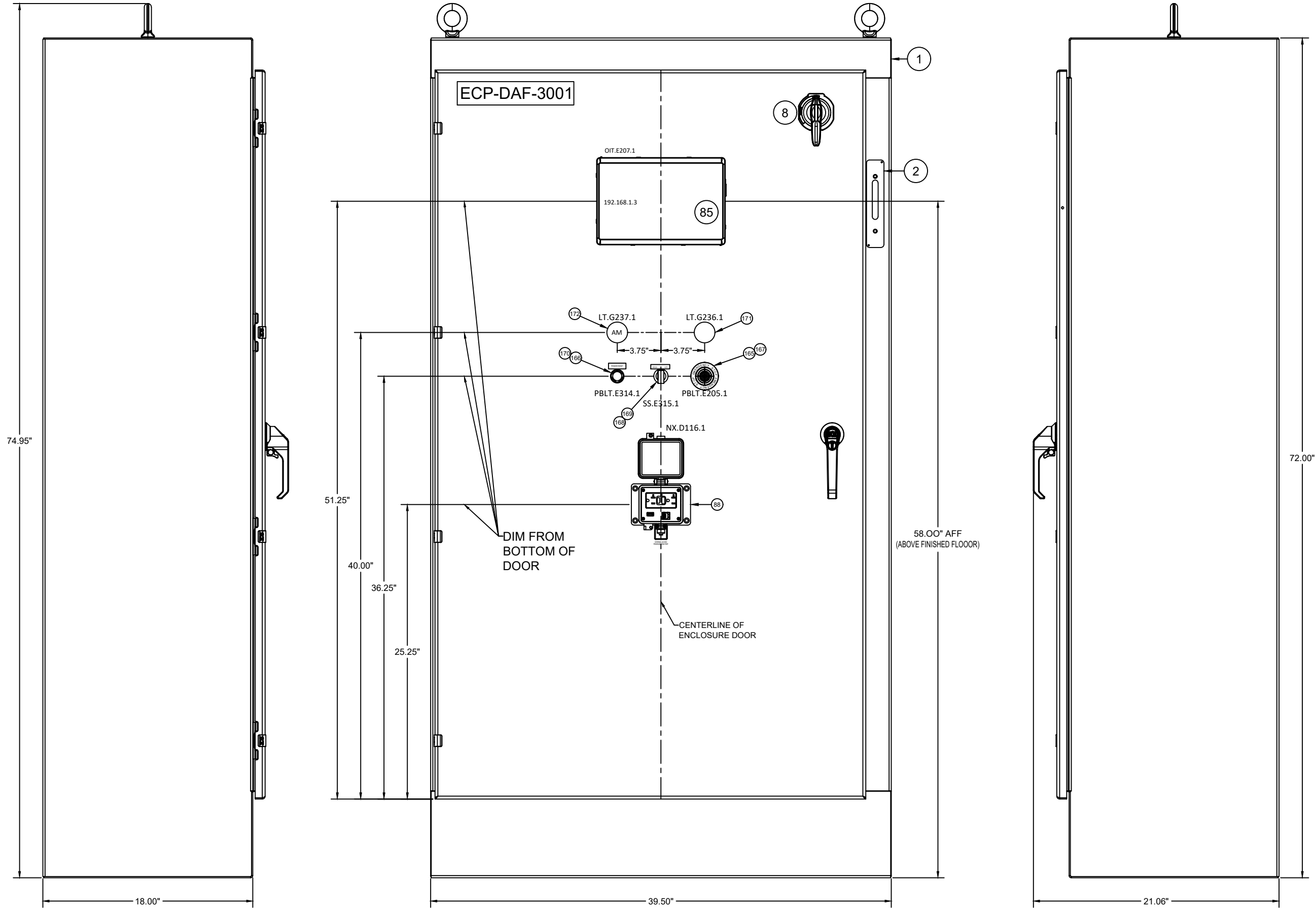

<b>RELEASED FOR: REVIEW</b>		<b>KROFTA Technologies LLC</b> PO Box 7 401 South Street Dalton MA 01227 Tel: 413.236.5634 Fax: 413.236.6917 info@krofta.com		SECTION: 56003EN25 DWN BY: CFW CHK'D BY:	DATE DWN: 04/15/2025 PROJECT NUM: 56003EN-25
REV. A A.1	BY CWF CWF	REVISION DESCRIPTION FOR REVIEW UPDATED PER CUSTOMER COMMENTS	<b>AUMSVILLE WWTP</b> AUMSVILLE, OR	DRAWING NUM: 56003EN25 0B01 SUB SEC: B	SHEET: 1 OF 9 REV: A.1

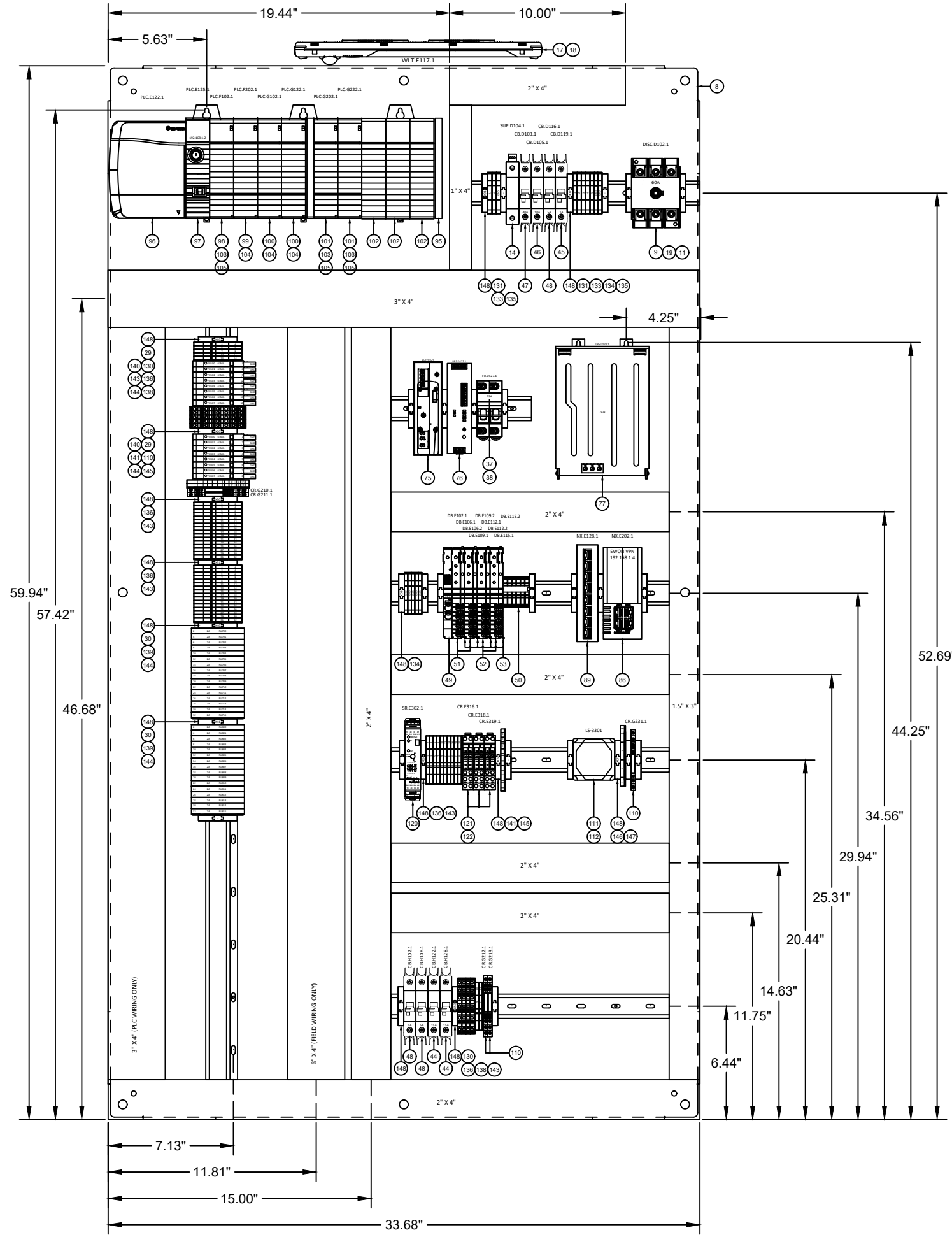

**AUMSVILLE WWTP**  
AUMSVILLE, OR



**Krofta Technologies LLC**  
PO Box 7  
401 South Street  
Dalton MA 01227  
Tel: 413.236.5634 Fax: 413.236.6917 info@krofta.com

REV.	DATE	BY	REVISION DESCRIPTION
A	04/15/2025	CFW	FOR REVIEW
A.1	05/29/2025	CFW	UPDATED PER CUSTOMER COMMENTS

ECP-DAF-3001  
INTERNAL LAYOUT

SECTION: DWN BY: CFW  
DRAWING NUM: 56003EN25\_0B02

CHK'D BY: DATE DWN: 04/15/2025  
SUB SEC: B  
PROJECT NUM: 56003EN-25  
SHEET: 2 OF: 9  
REV: A.1

RELEASED FOR: REVIEW

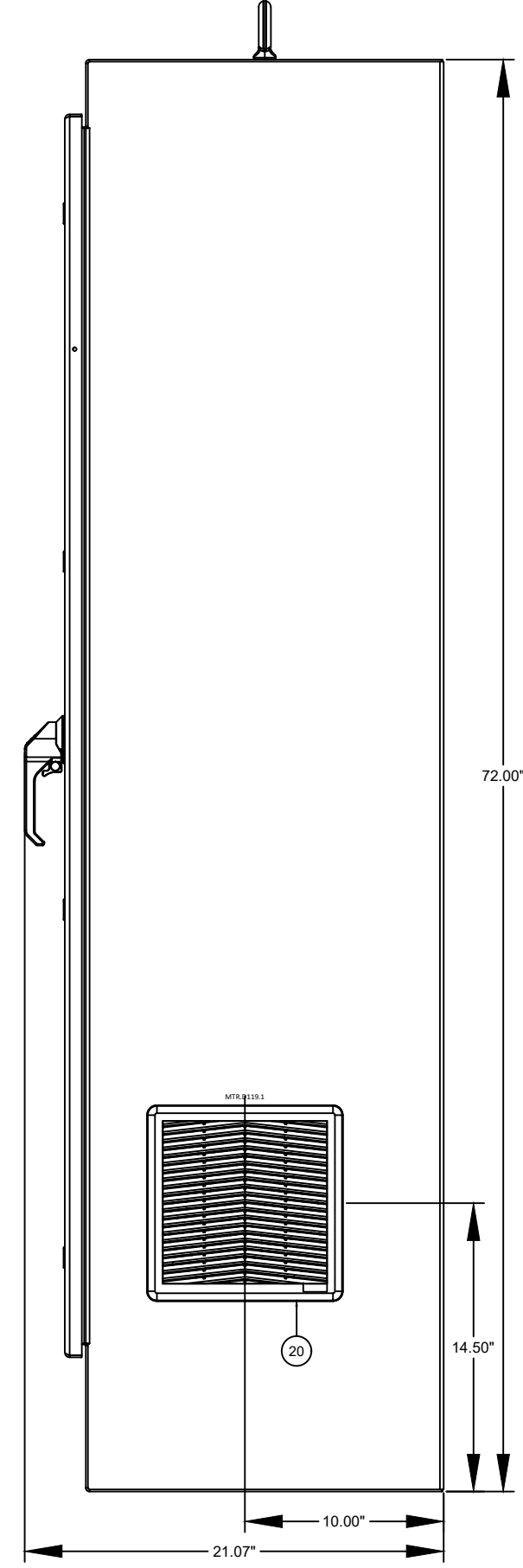
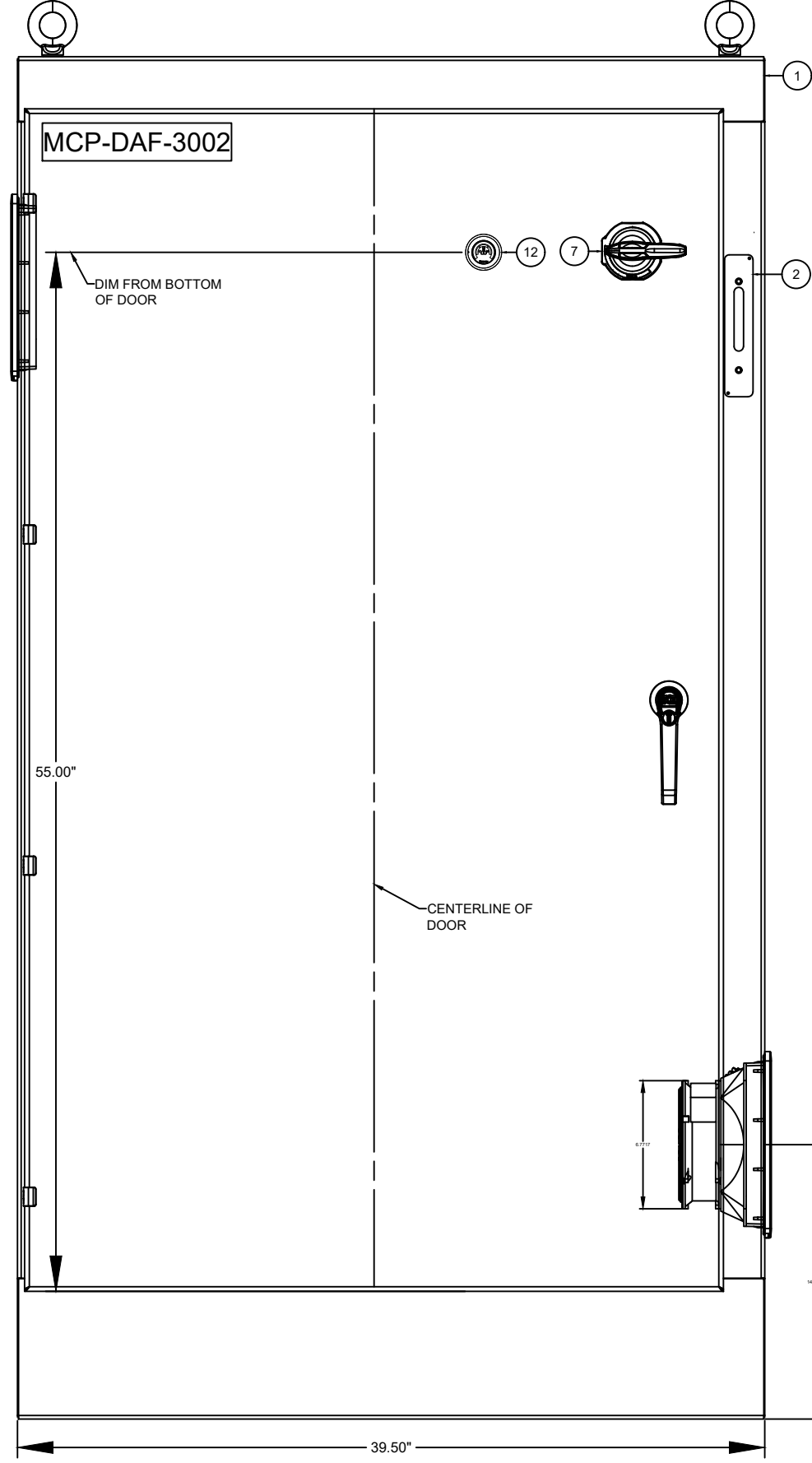
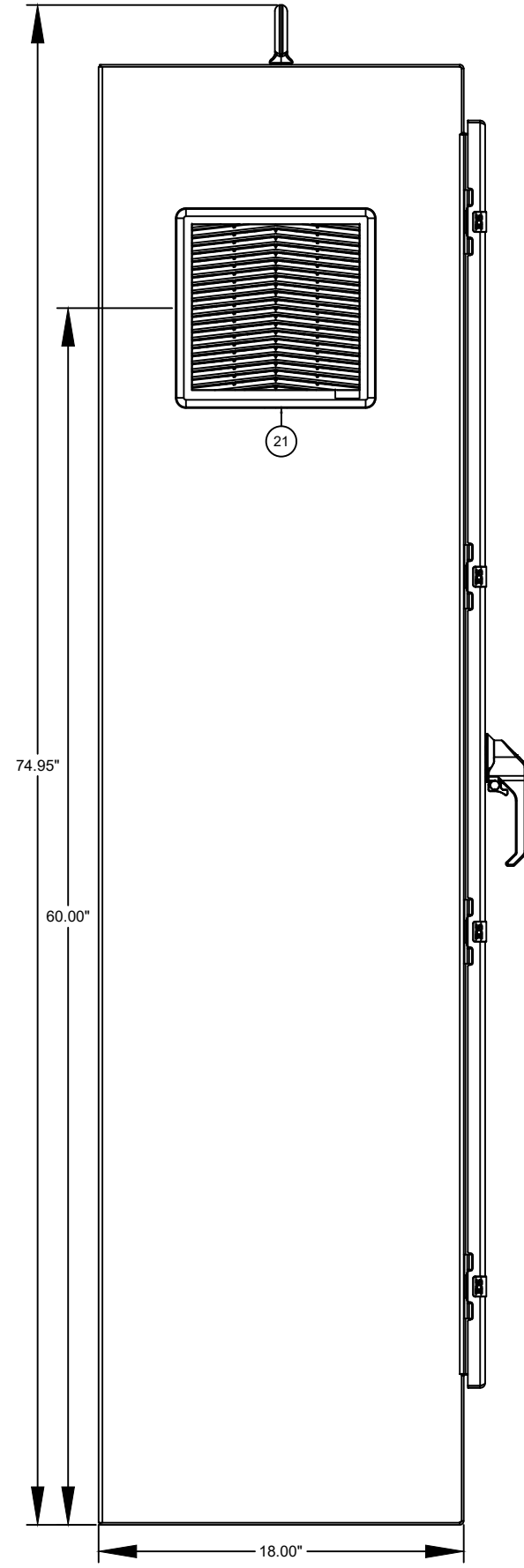

RELEASED FOR: REVIEW

REV.	DATE	BY	REVISION DESCRIPTION
A	04/15/2025	CWF	FOR REVIEW
A.1	05/29/2025	CWF	UPDATED PER CUSTOMER COMMENTS

**AUMSVILLE WWTP**  
AUMSVILLE, OR

MCP-DAF-3002  
EXTERNAL LAYOUT



**Krofta Technologies LLC**  
PO Box 7  
401 South Street  
Dalton MA 01227  
Tel: 413.236.5634 Fax: 413.236.6917 info@krofta.com

SECTION:	DWN BY:	CHK'D BY:	DATE DWN:	PROJECT NUM:
DRAWING NUM:	CFW	CFW	04/15/2025	56003EN-25
56003EN25_0B03		B	SHEET:	OF:
			3	9
			REV:	A.1

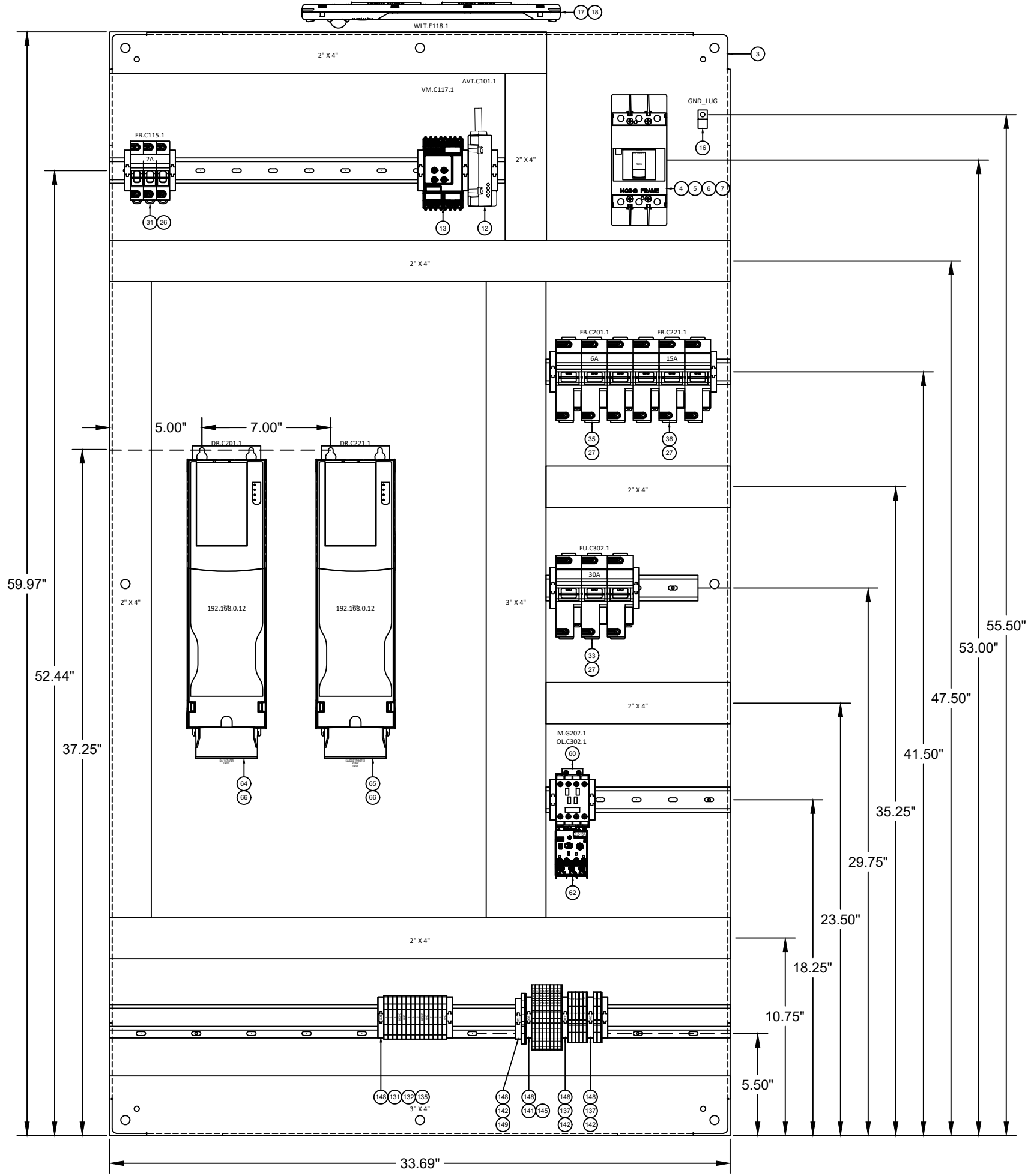

**AUMSVILLE WWTP**  
AUMSVILLE, OR

MCP-DAF-3002  
INTERNAL LAYOUT

RELEASED FOR: REVIEW

REV.	DATE	BY	REVISION DESCRIPTION
A	04/15/2025	CFW	FOR REVIEW
A.1	05/29/2025	CFW	UPDATED PER CUSTOMER COMMENTS



**Krofta Technologies LLC**  
PO Box 7  
401 South Street  
Dalton MA 01227  
Tel: 413.236.5634 Fax: 413.236.6917 info@krofta.com

SECTION:	DWN BY:	CHK'D BY:	DATE DWN:	PROJECT NUM:
DRAWING NUM:	CFW		04/15/2025	56003EN-25
56003EN25_0B04			SHEET:	OF:
			B	4 9
			REV:	A.1

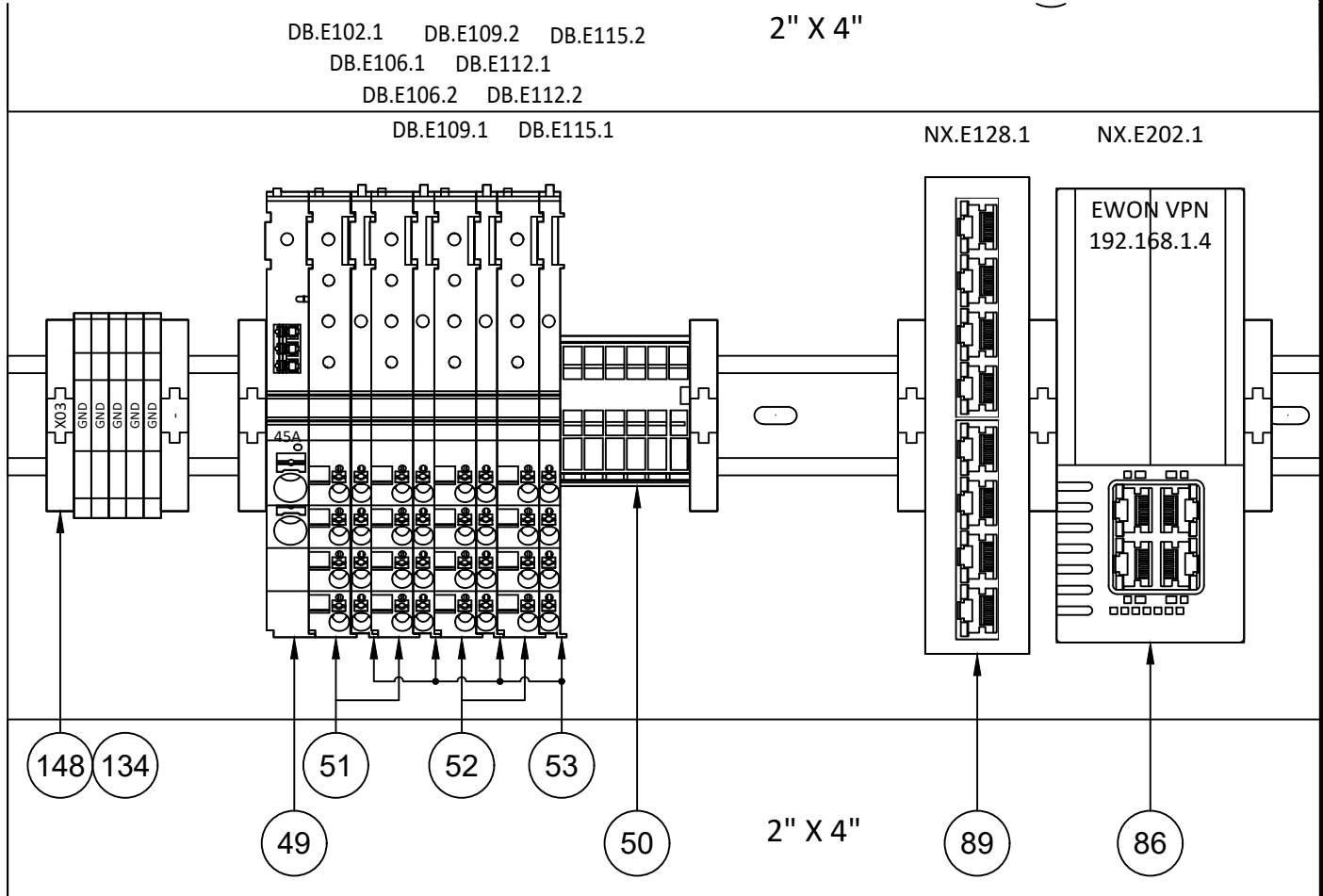
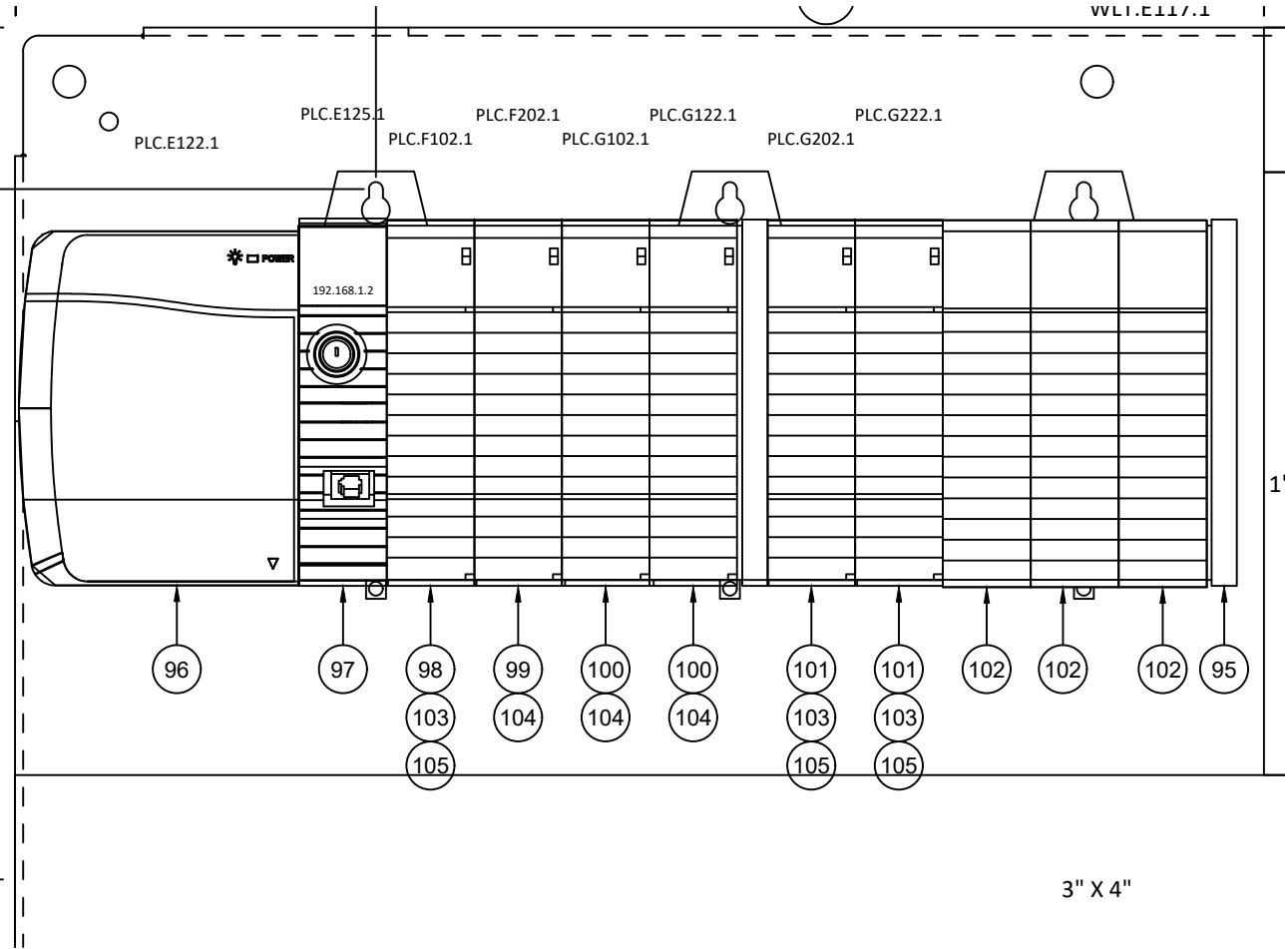
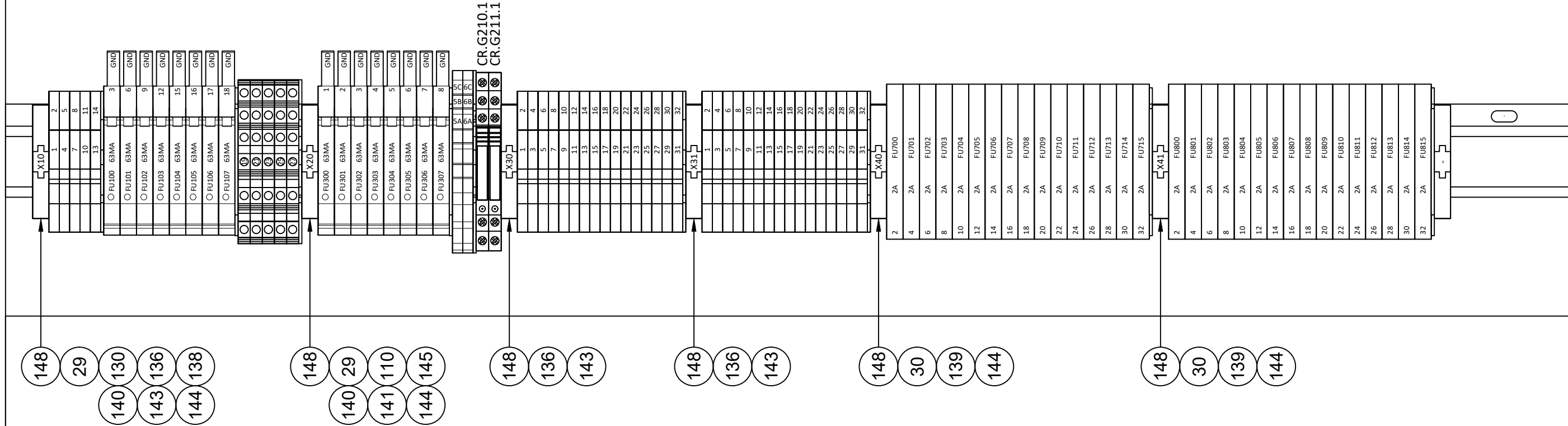

RELEASED FOR: REVIEW

REV.	DATE	BY	REVISION DESCRIPTION
A	04/15/2025	CFW	FOR REVIEW
A.1	05/29/2025	CFW	UPDATED PER CUSTOMER COMMENTS

**AUMSVILLE WWTP**  
AUMSVILLE, OR

ECP-DAF-3001  
PLC AND I/O TERMINALS DETAILS

**KROFTA Technologies LLC**  
PO Box 7, 401 South Street, Dalton MA 01227  
Tel: 413.236.5634 Fax: 413.236.6917 info@krofta.com

**KROFTA**

SECTION: DWN BY: CFW  
DRAWING NUM: 56003EN25 0B05

CHK'D BY: DATE DWN: 04/15/2025  
PROJECT NUM: 56003EN-25

SUB SEC: B  
SHEET: 5 OF 9  
REV: A.1

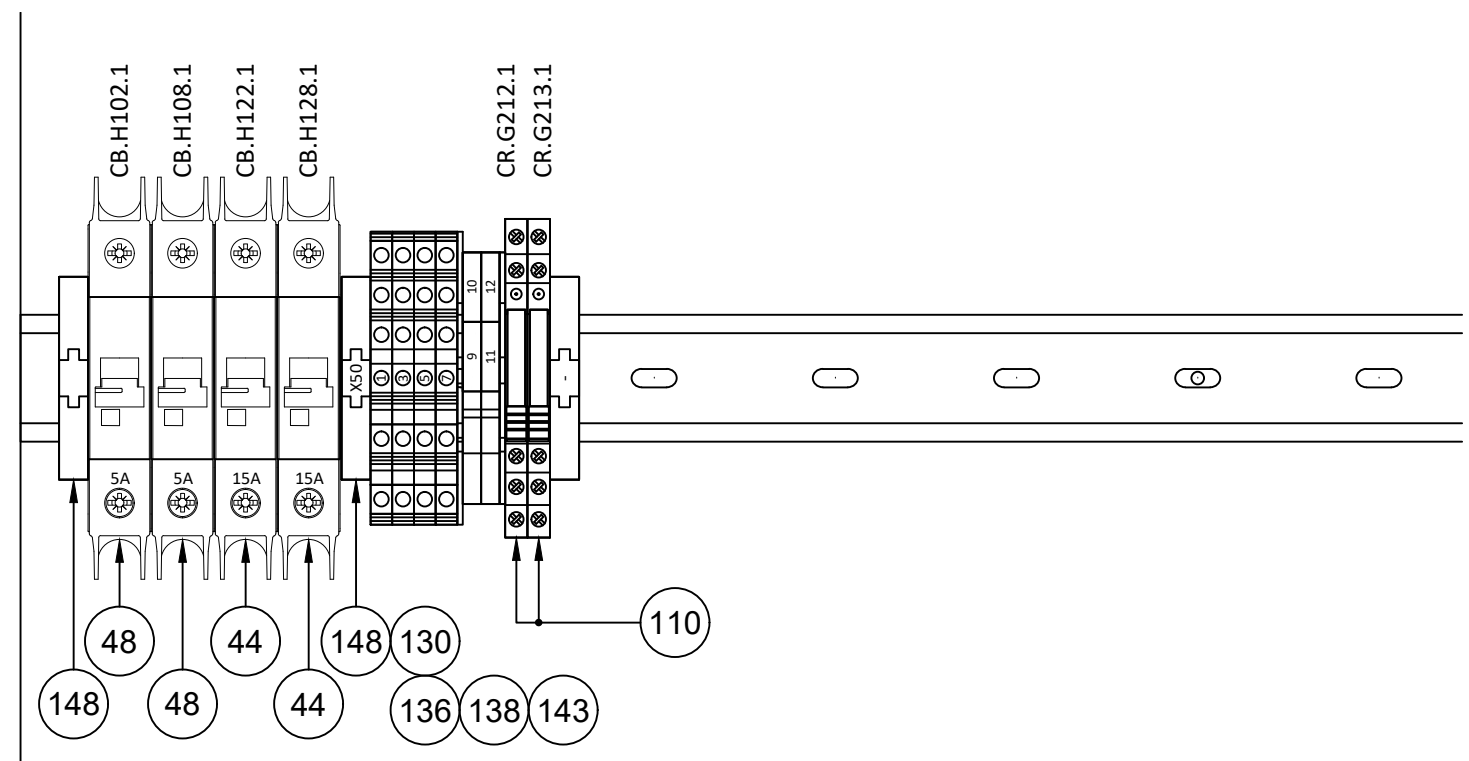
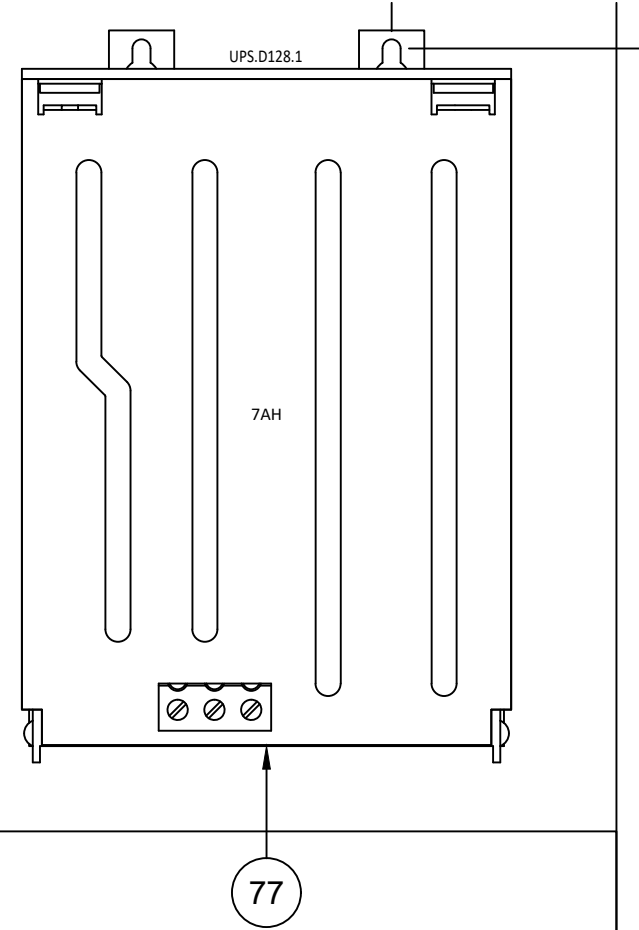
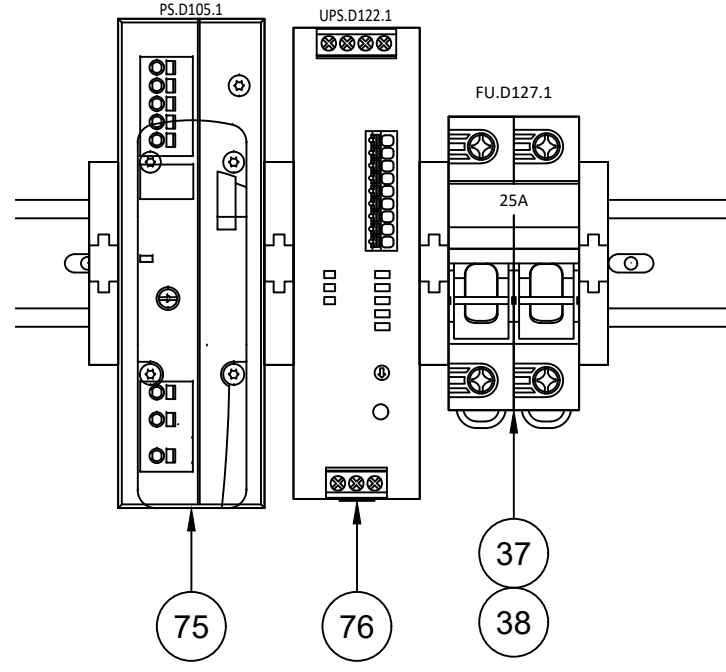
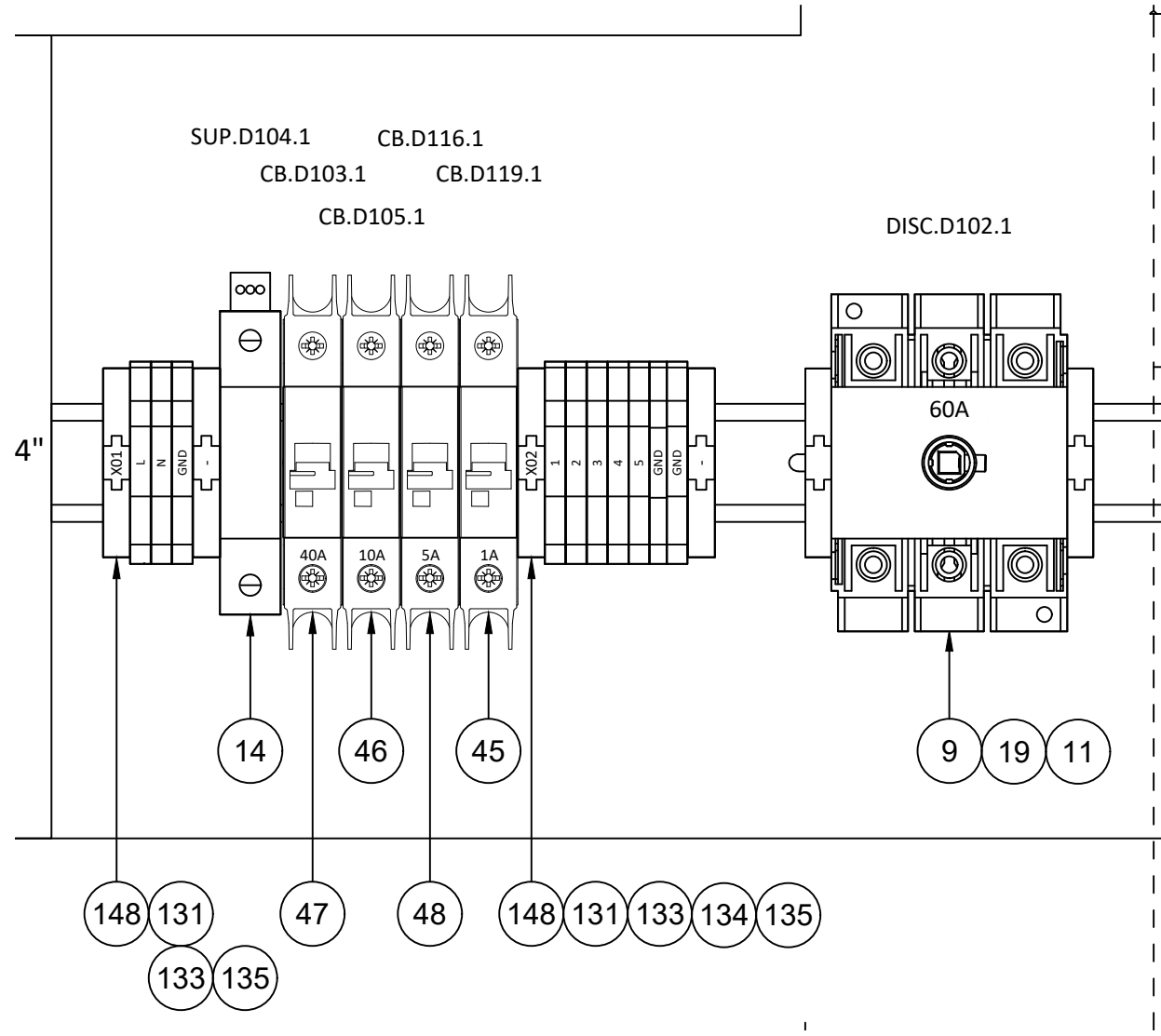

RELEASED FOR: REVIEW		REVISION DESCRIPTION	
REV. A	DATE 04/15/2025	BY CWF	FOR REVIEW
A.1	05/29/2025	CWF	UPDATED PER CUSTOMER COMMENTS
AUMSVILLE WWTP AUMSVILLE, OR		ECP-DAF-3001 POWER DISTRIBUTION & NETWORK SWITCH DETAILS	
KROFTA Technologies LLC PO Box 7 401 South Street Dalton MA 01227 Tel: 413.236.5634 Fax: 413.236.6917 info@krofta.com		PROJECT NUM: 56003EN-25	
SECTION: 56003EN25_0B06	DWN BY: CFW	CHK'D BY:	DATE DWN: 04/15/2025
DRAWING NUM: 56003EN25_0B06	SUB SEC: B	SHEET: 6	OF: 9
		REV: A.1	

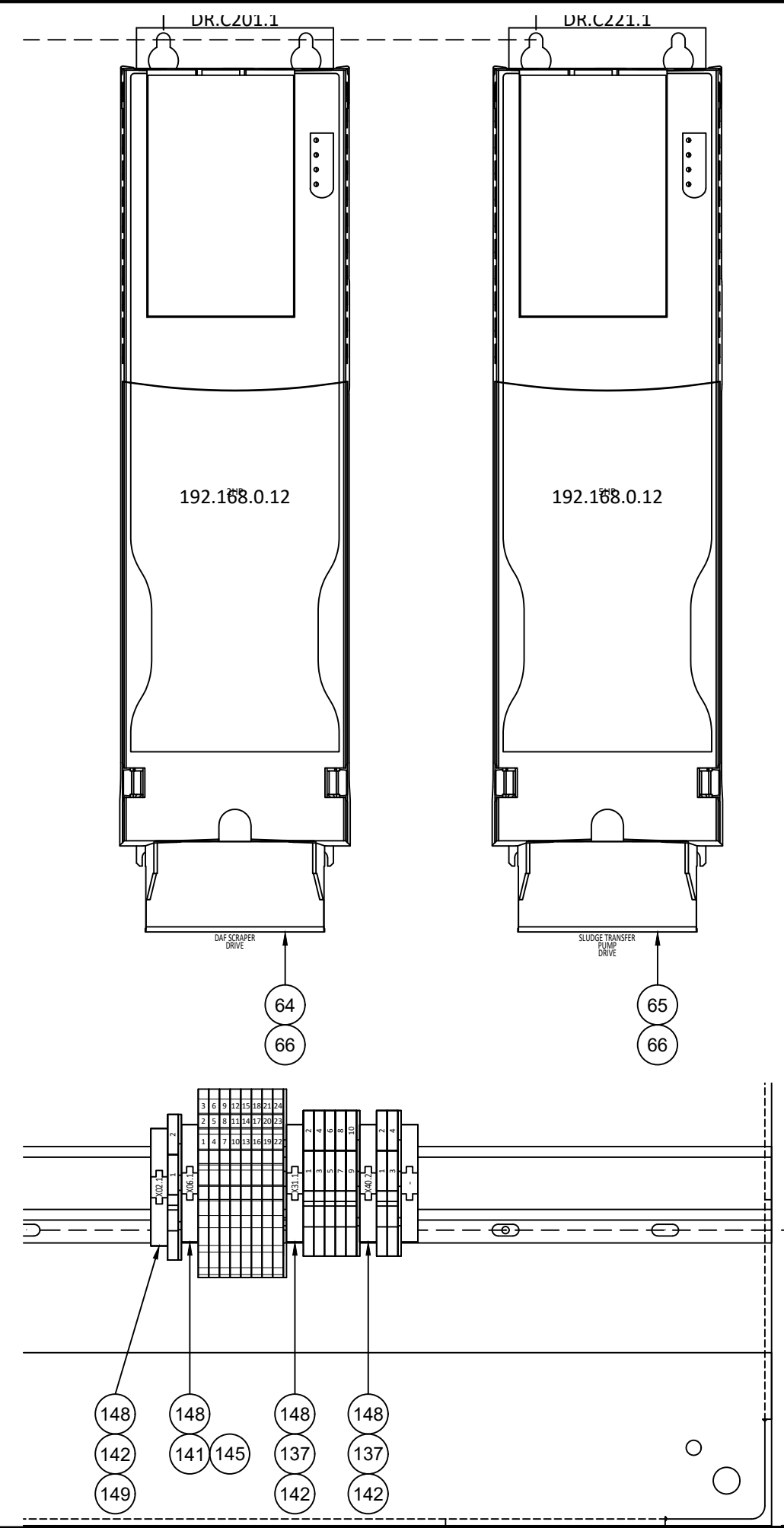
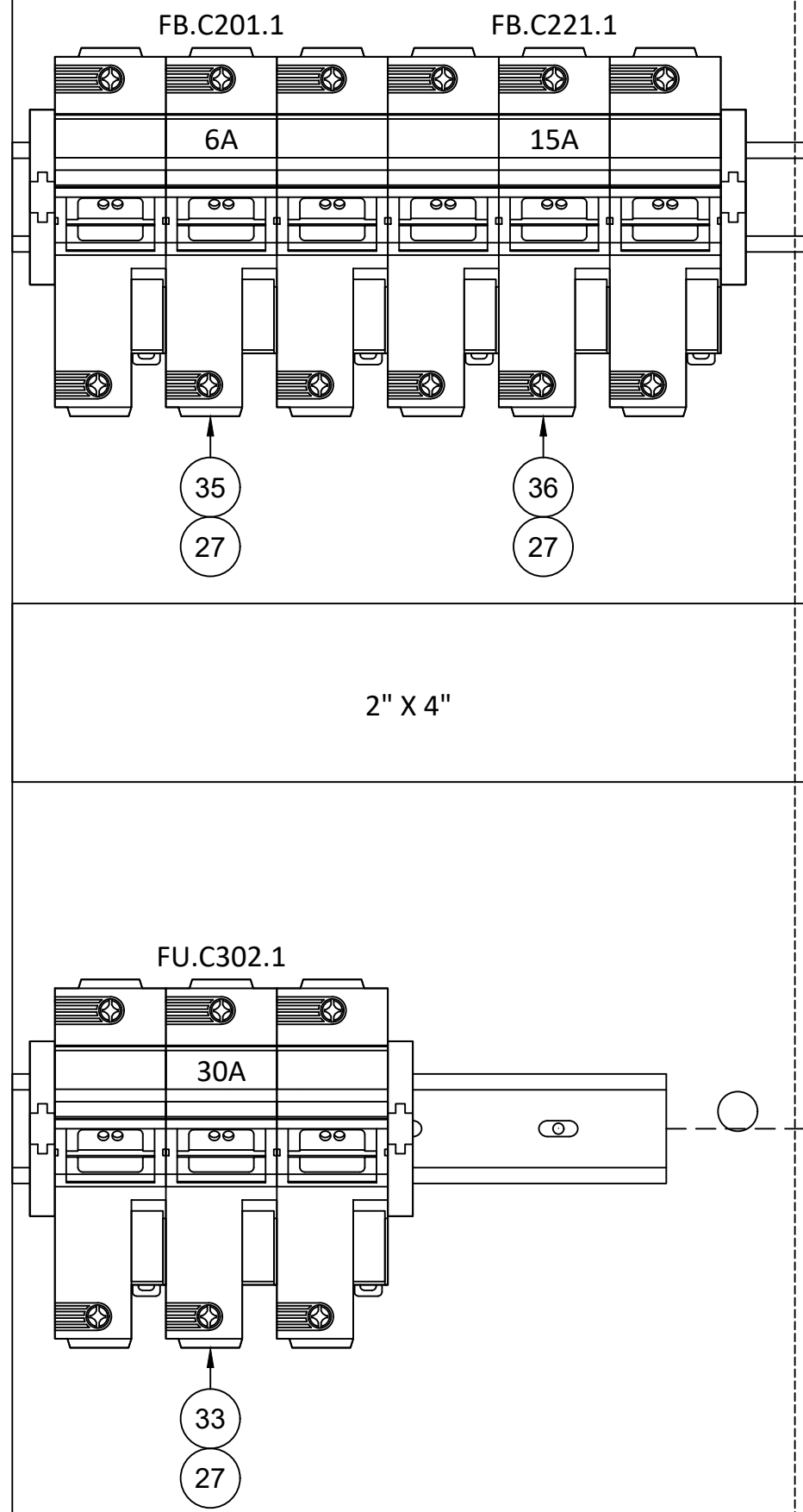
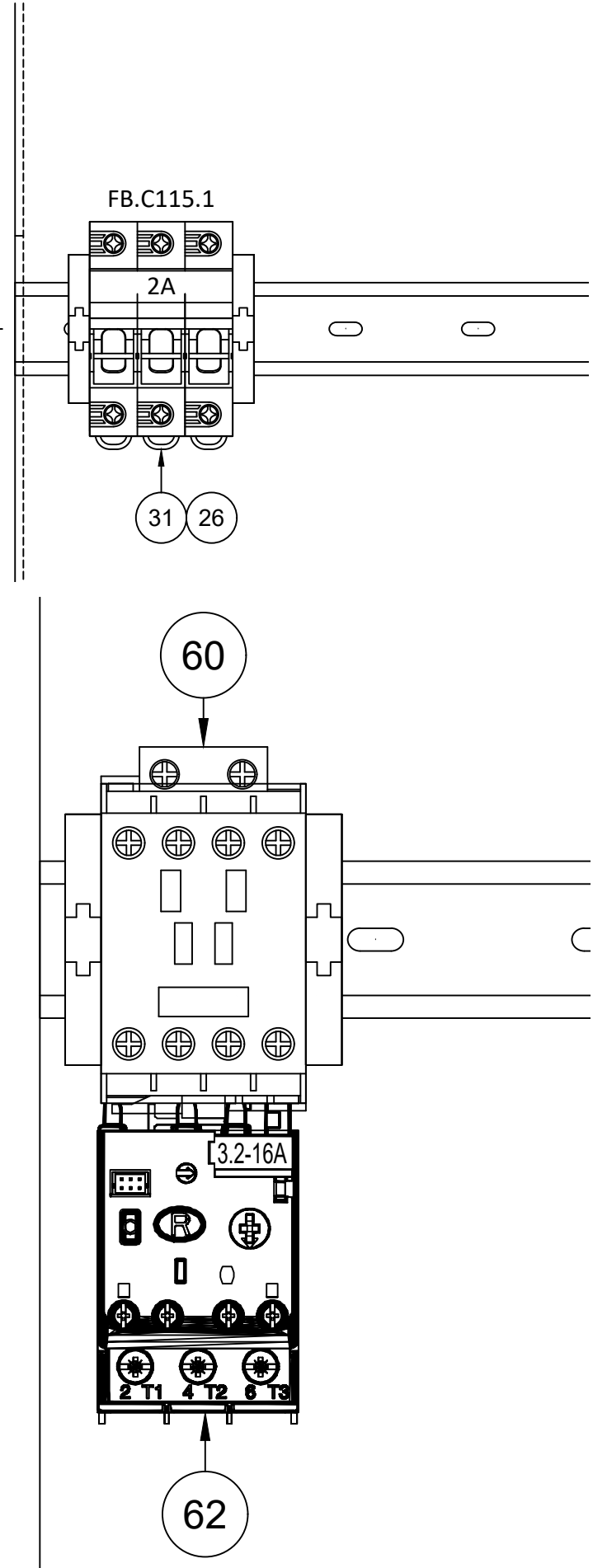

RELEASED FOR: REVIEW		REVISION DESCRIPTION	
REV. A	DATE 04/15/2025	BY CWF	FOR REVIEW
A.1	05/29/2025	CWF	UPDATED PER CUSTOMER COMMENTS
AUMSVILLE WWTP AUMSVILLE, OR		MCP-DAF-3002 480VAC POWER DISTRIBUTION DETAILS	
KROFTA Technologies LLC PO Box 7 401 South Street Dalton MA 01227 Tel: 413.236.5634 Fax: 413.236.6917 info@krofta.com		SECTION: 56003EN25_0B07	DRAWING NUM: 56003EN-25
DWN BY: CFW	CHK'D BY:	DATE DWN: 04/15/2025	PROJECT NUM: 56003EN-25
SUB SEC: B	SHEET: 7	OF: 9	REV: A.1

RELEASED FOR: REVIEW

REV.	DATE	BY	REVISION DESCRIPTION
A	04/15/2025	CWF	FOR REVIEW
A.1	05/29/2025	CWF	UPDATED PER CUSTOMER COMMENTS

AUMSVILLE WWTP  
AUMSVILLE, OR

MCP-DAF-3002  
SPARE SHEET



**Krofta Technologies LLC**  
PO Box 7  
401 South Street  
Dalton MA 01227  
Tel: 413.236.5634 Fax: 413.236.6917 info@krofta.com

SECTION:	DWN BY:	CHK'D BY:	DATE DWN:	PROJECT NUM:
DRAWING NUM: 56003EN25 0B08	CFW		04/15/2025	56003EN-25
		SUB SEC: B	SHEET: 8	OF: 9
				REV: A.1

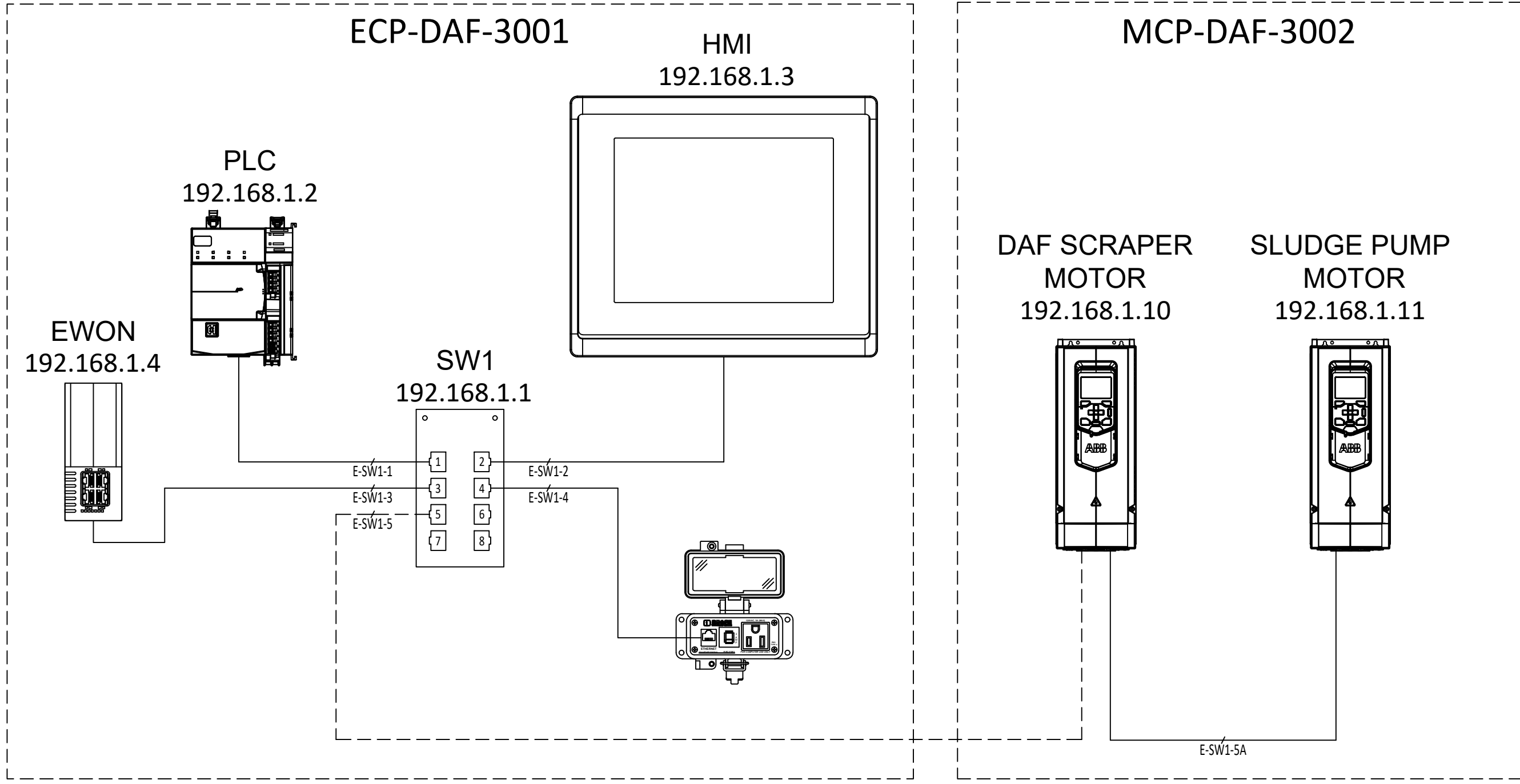

THESE IP ADDRESSES CONFORM TO KROFTA STANDARDS  
 ANY CHANGES SHOULD BE CONVEYED PRIOR TO COMMISSIONING OF THE SYSTEM.

<b>KROFTA</b> <b>Krofta Technologies LLC</b> PO Box 7, 401 South Street, Dalton MA 01227 Tel: 413.236.5634 Fax: 413.236.6917 info@krofta.com		SECTION:	DWN BY:	CHK'D BY:	DATE DWN:	PROJECT NUM:
		DRAWING NUM:	CFW	CFW	04/15/2025	56003EN-25
<b>AUMSVILLE WWTP</b> AUMSVILLE, OR		DRAWING NUM:	SUB SEC:	SHEET:	OF:	REV:
NETWORK LAYOUT		56003EN25_0B09	B	9	9	A.1
RELEASED FOR: REVIEW	REVISION DESCRIPTION	DATE 04/15/2025	BY CWF	FOR REVIEW	UPDATED PER CUSTOMER COMMENTS	
A.1		05/29/2025	CWF			

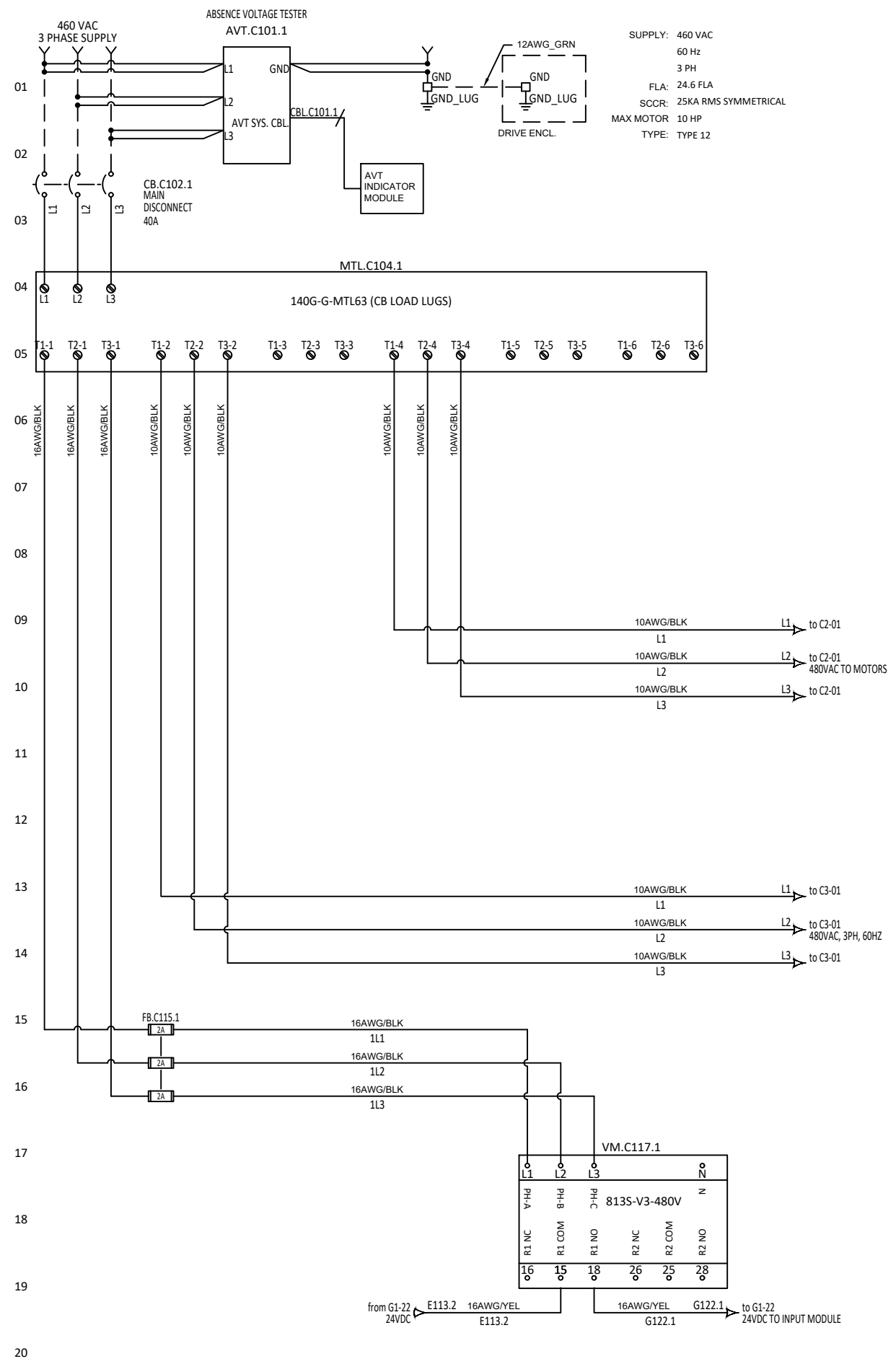

21

22

23

24

25

26

27

28

29

30

31

32

33

34

35

36

37

38

39

40

**AUMSVILLE WWTP**  
AUMSVILLE, OR



**Krofta Technologies LLC**  
PO Box 7  
401 South Street  
Dalton MA 01227  
Tel: 413.236.5634 Fax: 413.236.6917 info@krofta.com

RELEASED FOR: REVIEW

REV.	DATE	BY	REVISION DESCRIPTION
A	04/15/2025	CWF	FOR REVIEW
A.1	05/29/2025	CWF	UPDATED PER CUSTOMER COMMENTS

MCP-DAF-3002  
3 PHASE WIRING

SECTION: DWN BY: CFW  
DRAWING NUM: 56003EN25\_0C01

CHK'D BY: DATE DWN: PROJECT NUM:  
04/15/2025 56003EN-25

SUB SEC: SHEET: OF: REV:  
C 1 3 A.1

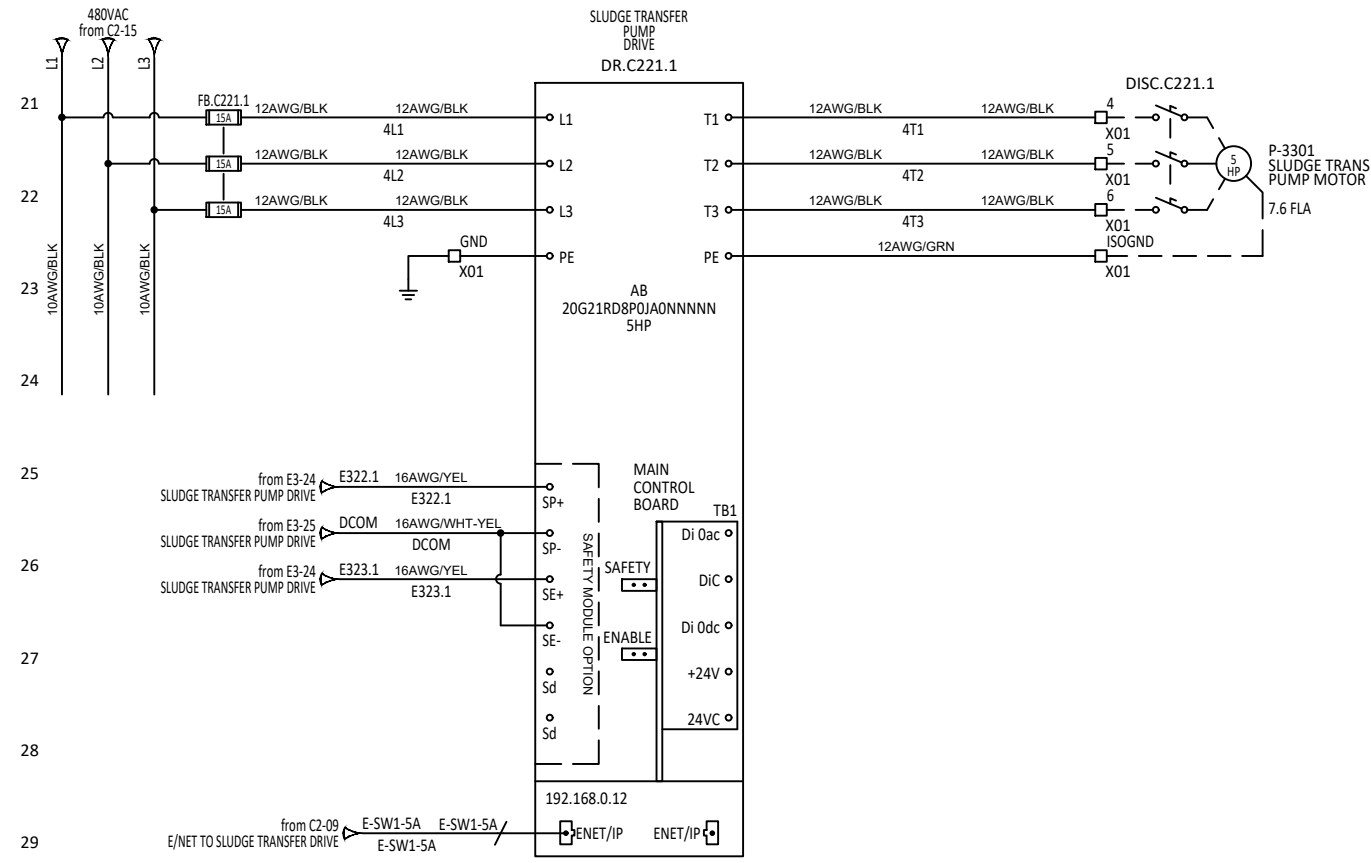
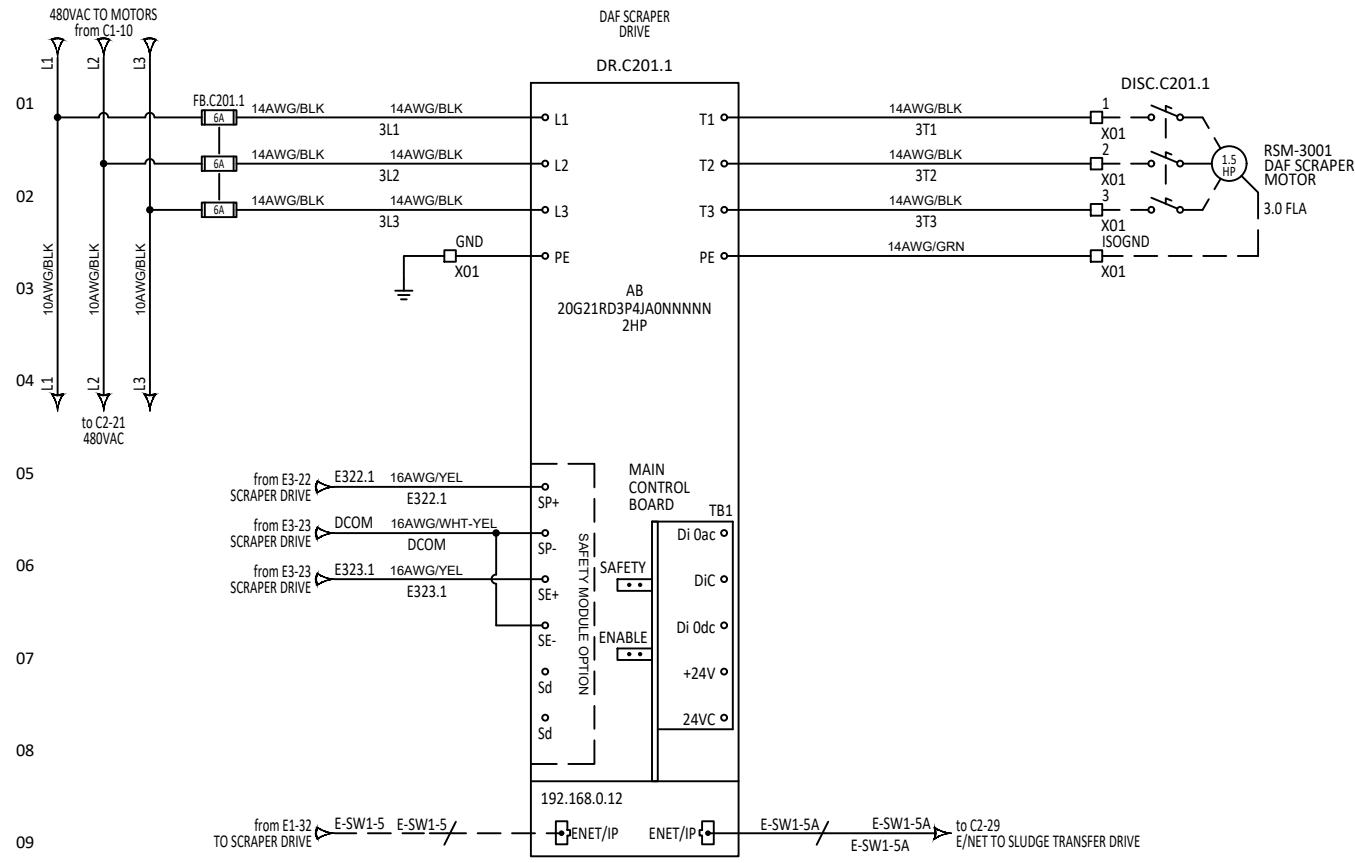

01  
02  
03  
04  
05  
06  
07  
08  
09  
10  
11  
12  
13  
14  
15  
16  
17  
18  
19  
20

21  
22  
23  
24  
25  
26  
27  
28  
29  
30  
31  
32  
33  
34  
35  
36  
37  
38  
39  
40

RELEASED FOR: REVIEW		REVISION DESCRIPTION	
REV.	DATE	BY	
A	04/15/2025	CWF	FOR REVIEW
A.1	05/29/2025	CWF	UPDATED PER CUSTOMER COMMENTS
AUMSVILLE WWTP AUMSVILLE, OR		MCP-DAF-3002 3 PHASE WIRING	
KROFTA Technologies LLC PO Box 7 401 South Street Dalton MA 01227 Tel: 413.236.5634 Fax: 413.236.6917 info@krofta.com		PROJECT NUM: 56003EN-25	
SECTION: 56003EN25_0C02	DWN BY: CFW	CHK'D BY: CFW	DATE DWN: 04/15/2025
DRAWING NUM: 56003EN25_0C02	SUB SEC: C	SHEET: 2	OF: 3
		REV: A.1	

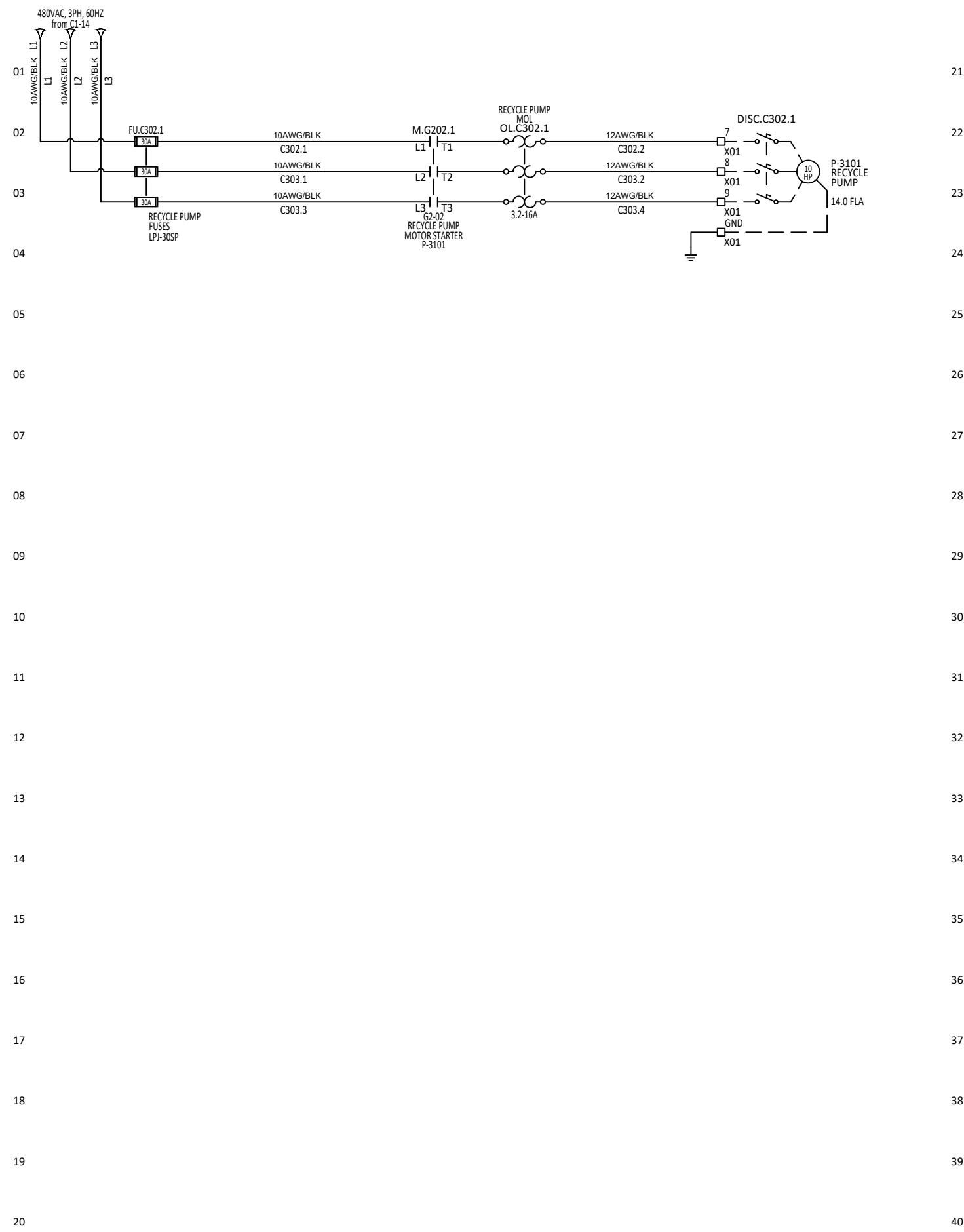

01  
02  
03  
04  
05  
06  
07  
08  
09  
10  
11  
12  
13  
14  
15  
16  
17  
18  
19  
20

21  
22  
23  
24  
25  
26  
27  
28  
29  
30  
31  
32  
33  
34  
35  
36  
37  
38  
39  
40

RELEASED FOR: REVIEW

REV.	DATE	BY	REVISION DESCRIPTION
A	04/15/2025	CWF	FOR REVIEW
A.1	05/29/2025	CWF	UPDATED PER CUSTOMER COMMENTS

**AUMSVILLE WWTP**  
AUMSVILLE, OR

MCP-DAF-3002  
3 PHASE WIRING



**Krofta Technologies LLC**  
PO Box 7  
401 South Street  
Dalton MA 01227  
Tel: 413.236.5634 Fax: 413.236.6917 info@krofta.com

SECTION: DWN BY: CFW  
DRAWING NUM: 56003EN25\_0C03

CHK'D BY: DATE DWN: 04/15/2025  
SUB SEC: C  
PROJECT NUM: 56003EN-25  
SHEET: 3 OF: 3  
REV: A.1



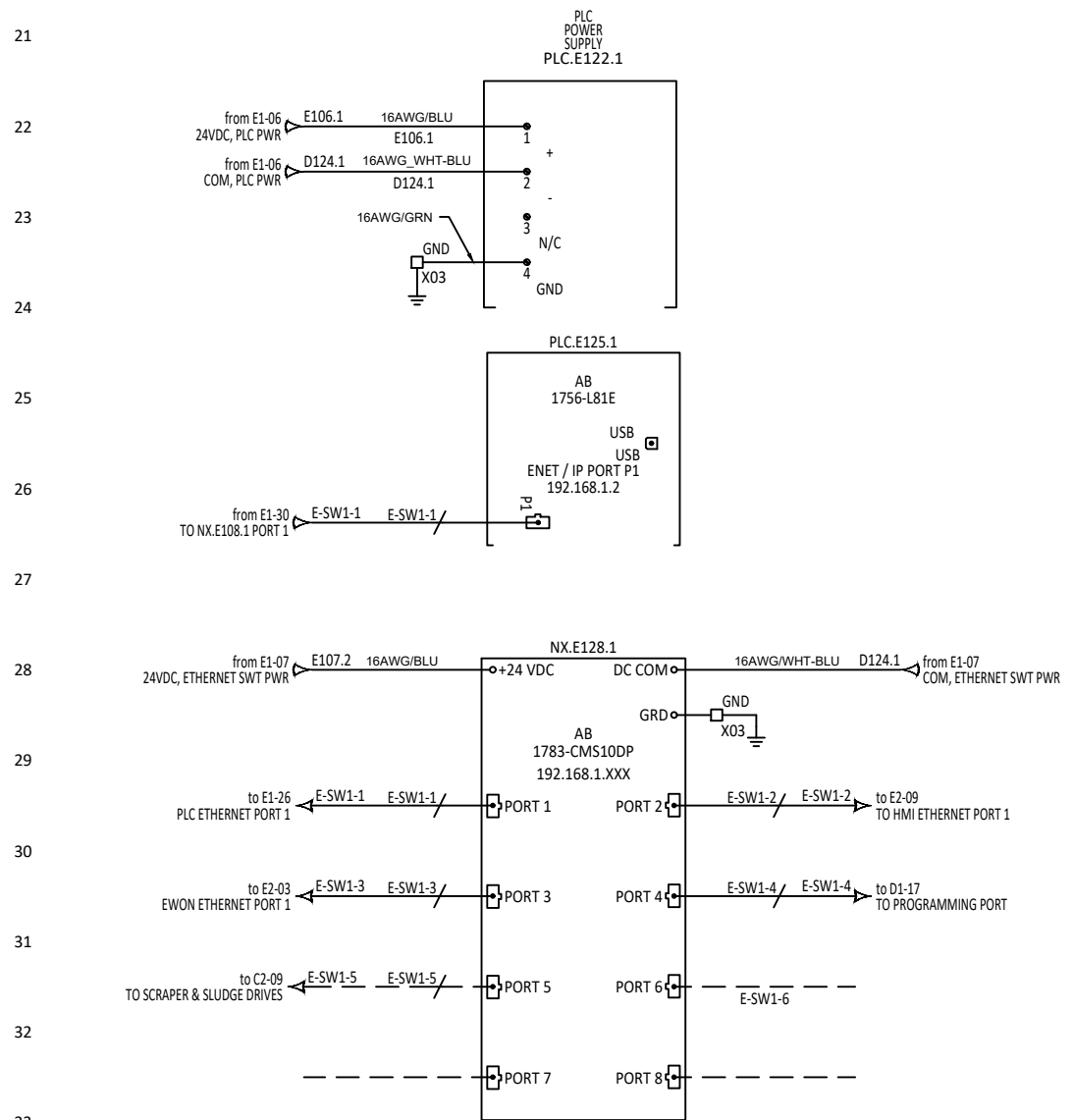
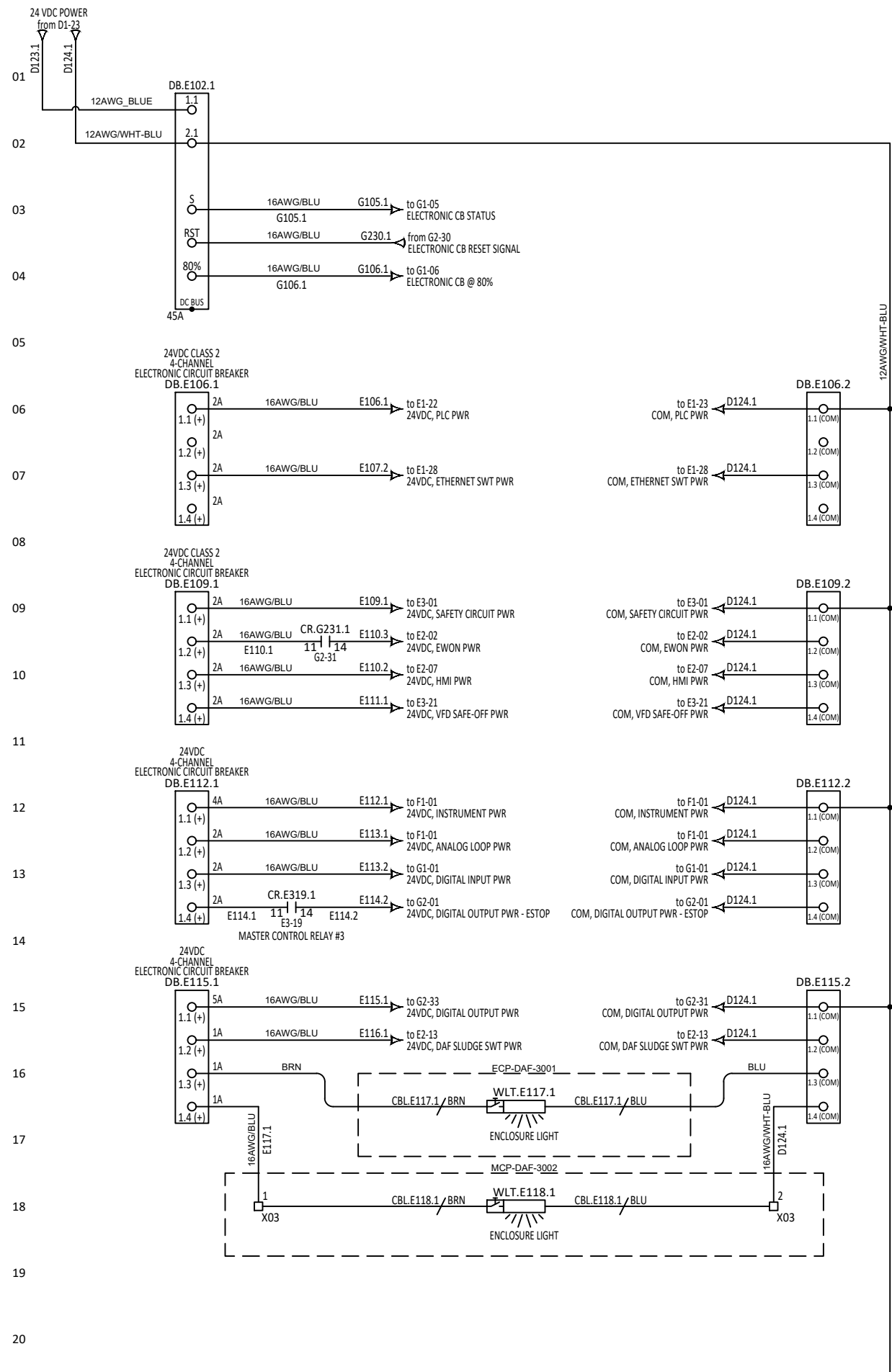

RELEASED FOR: REVIEW		REVISION DESCRIPTION	
REV. A	DATE 04/15/2025	BY CWF	FOR REVIEW
A.1	05/29/2025	CWF	UPDATED PER CUSTOMER COMMENTS
KROFTA Technologies LLC 401 South Street Dalton MA 01227 Tel: 413.236.5634 Fax: 413.236.6917 info@krofta.com		SECTION: 56003EN25 0E01	DRAWING NUM: 56003EN-25
AUMSVILLE WWTP AUMSVILLE, OR		CHK'D BY: CFW	DATE DWN: 04/15/2025
CONTROL WIRING		DWN BY: CFW	PROJECT NUM: 56003EN-25
		SUB SEC: E	SHEET: 1 OF 3
			REV: A.1

01  
02  
03  
04  
05  
06  
07  
08  
09  
10  
11  
12  
13  
14  
15  
16  
17  
18  
19  
20

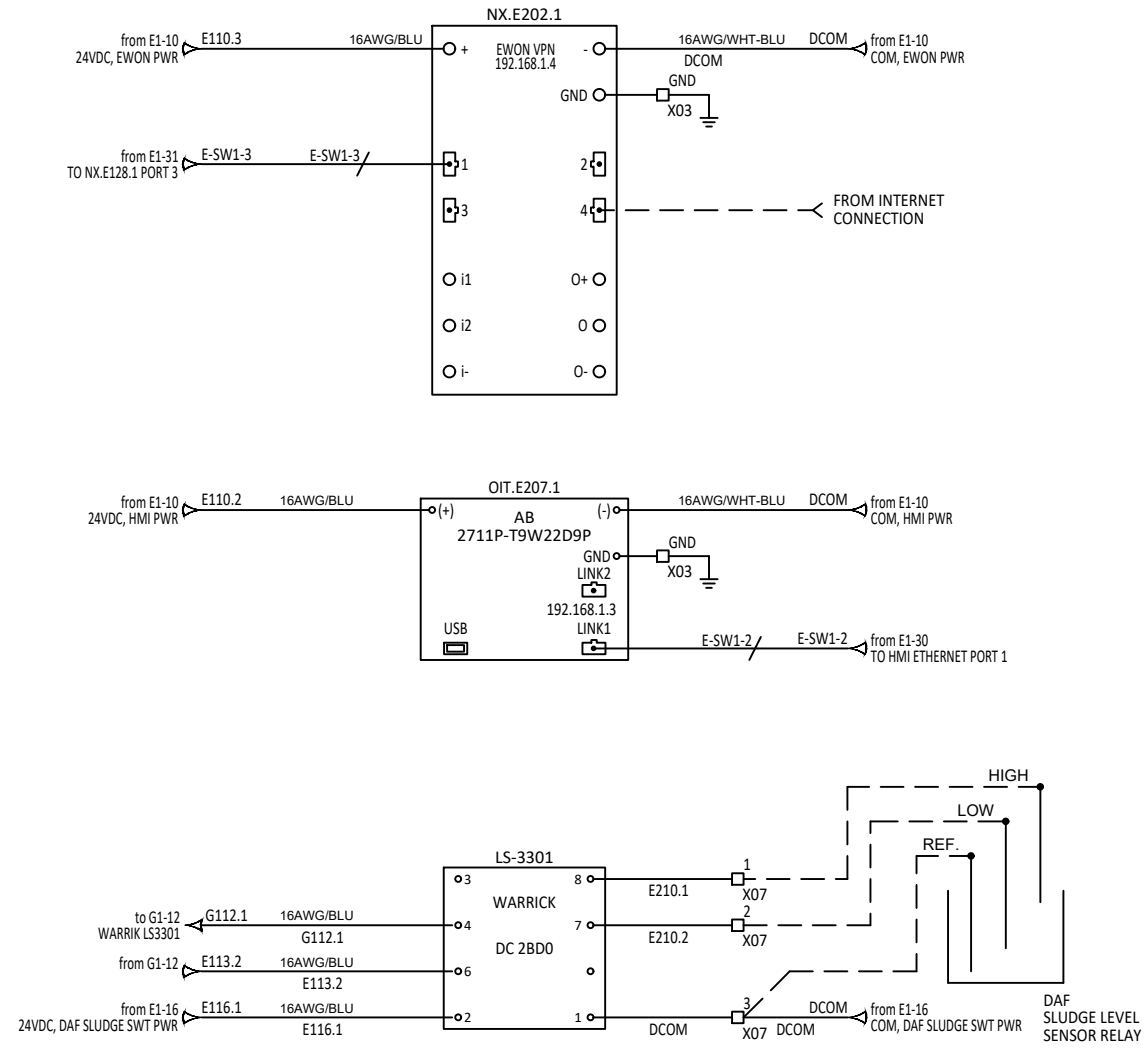

21  
22  
23  
24  
25  
26  
27  
28  
29  
30  
31  
32  
33  
34  
35  
36  
37  
38  
39  
40

RELEASED FOR: REVIEW

REV.	DATE	BY	REVISION DESCRIPTION
A	04/15/2025	CWF	FOR REVIEW
A.1	05/29/2025	CWF	UPDATED PER CUSTOMER COMMENTS

**AUMSVILLE WWTP**  
AUMSVILLE, OR

CONTROL WIRING



**Krofta Technologies LLC**  
PO Box 7  
401 South Street  
Dalton MA 01227  
Tel: 413.236.5634 Fax: 413.236.6917 info@krofta.com

SECTION:	DWN BY:	CHK'D BY:	DATE DWN:	PROJECT NUM:
DRAWING NUM: 56003EN25 0E02	CWF		04/15/2025	56003EN-25
			SHEET:	OF:
			2	3
			REV:	A.1

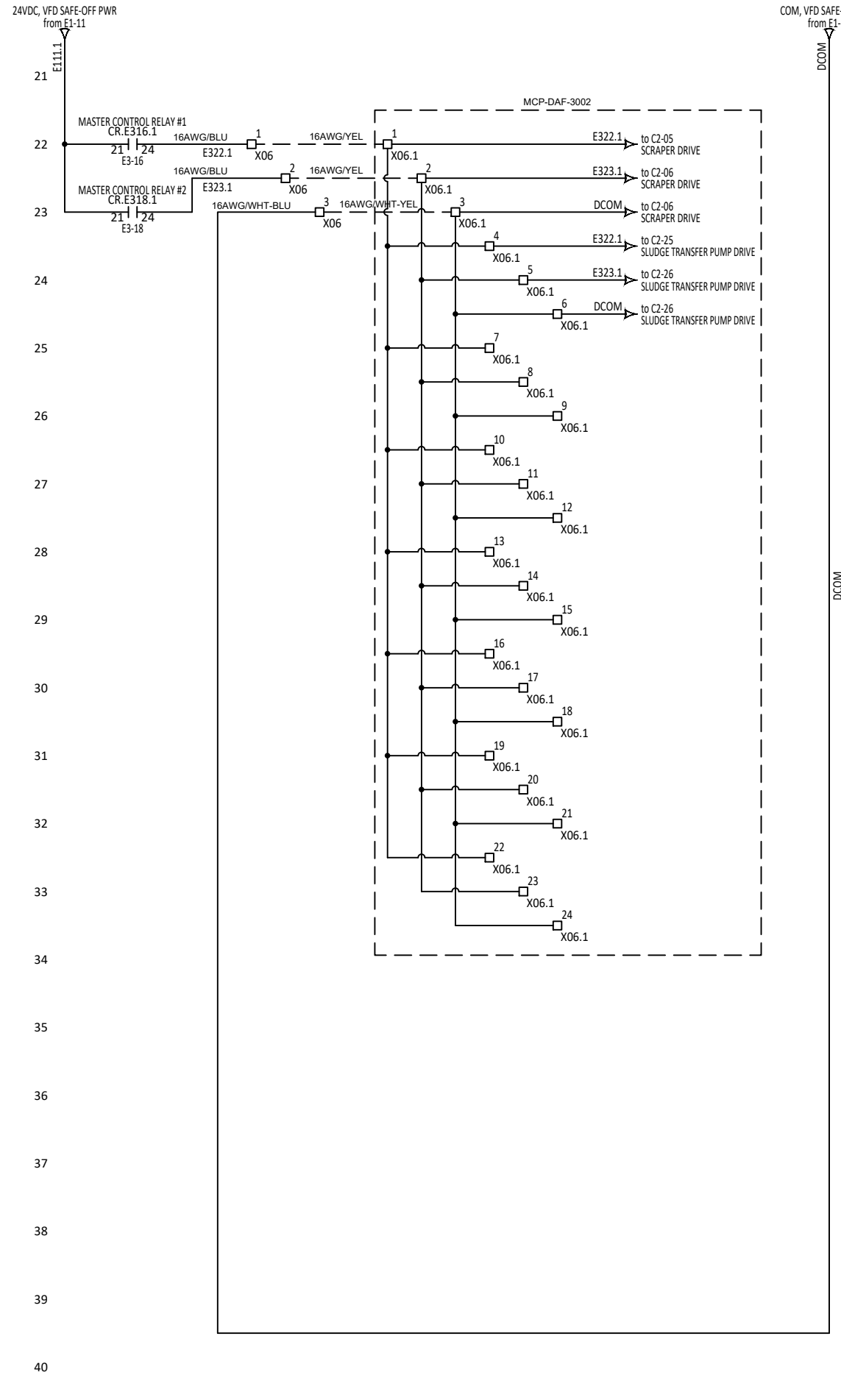
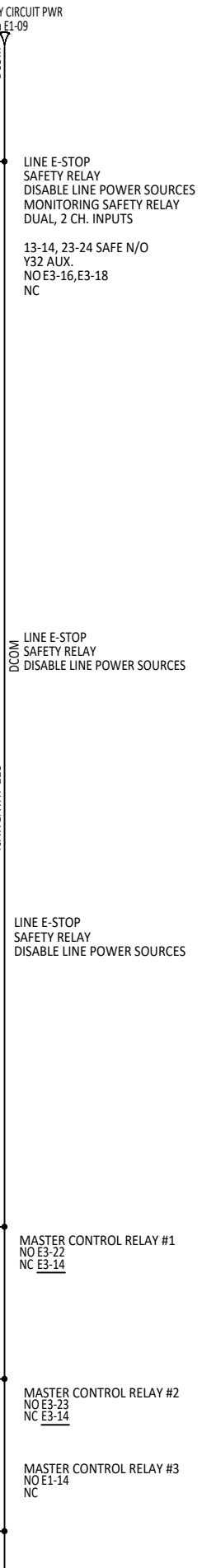
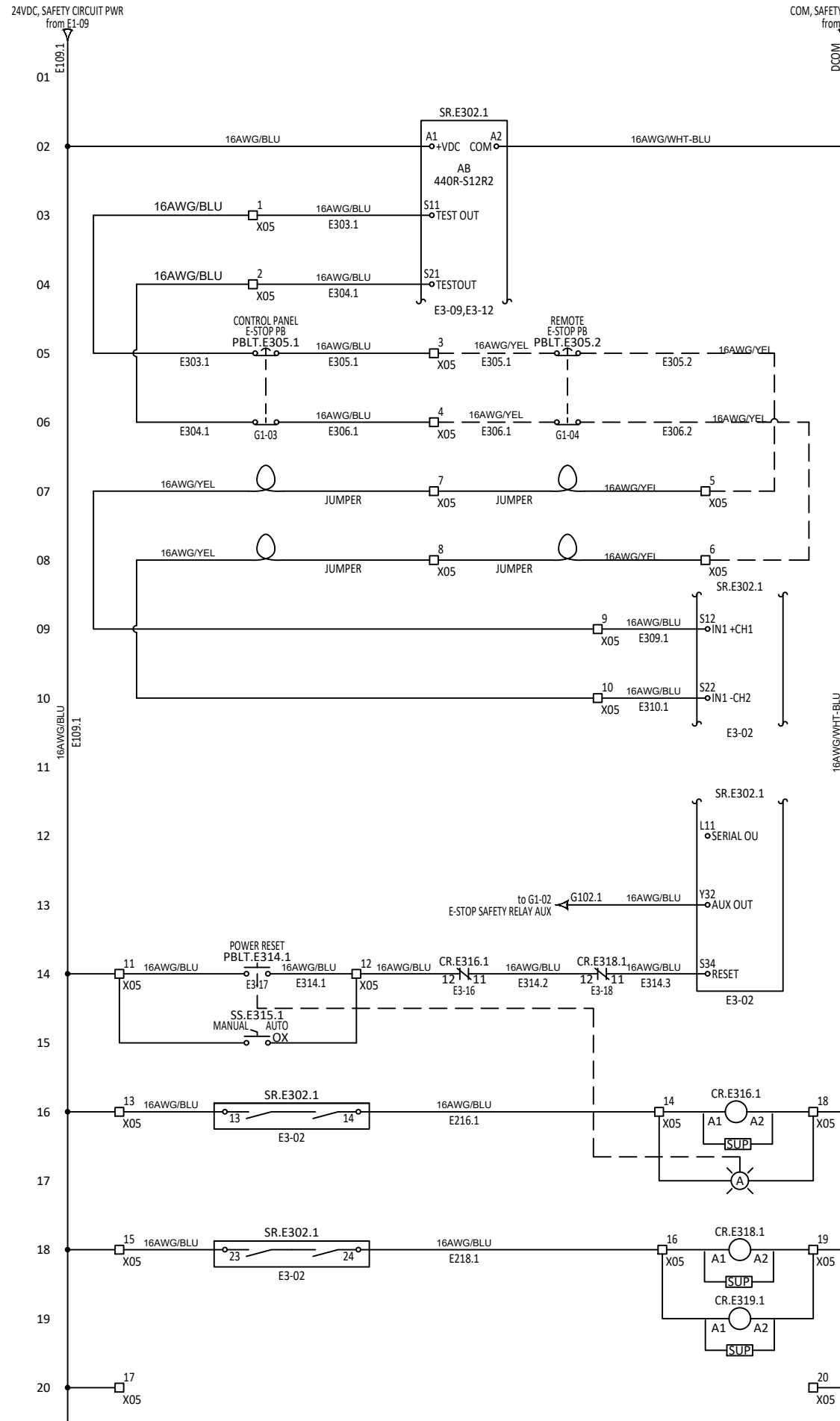

**RELEASED FOR: REVIEW**

REV.	DATE	BY	REVISION DESCRIPTION
A	04/15/2025	CFW	FOR REVIEW
A.1	05/29/2025	CFW	UPDATED PER CUSTOMER COMMENTS

**Krofta Technologies LLC**  
 401 South Street, Dalton MA 01227  
 Tel: 413.236.5634 Fax: 413.236.6917 info@krofta.com

**KROFTA**

**AUMSVILLE WWTP**  
 AUMSVILLE, OR

**E-STOP SAFETY CIRCUIT**  
 DRIVE SAFE OFF

SECTION:	DWN BY:	CHK'D BY:	DATE DWN:	PROJECT NUM:
56003EN25 0E03	CFW	CFW	04/15/2025	56003EN-25
DRAWING NUM:	SUB SEC:	SHEET:	OF:	REV:
56003EN25 0E03	E	3	3	A.1

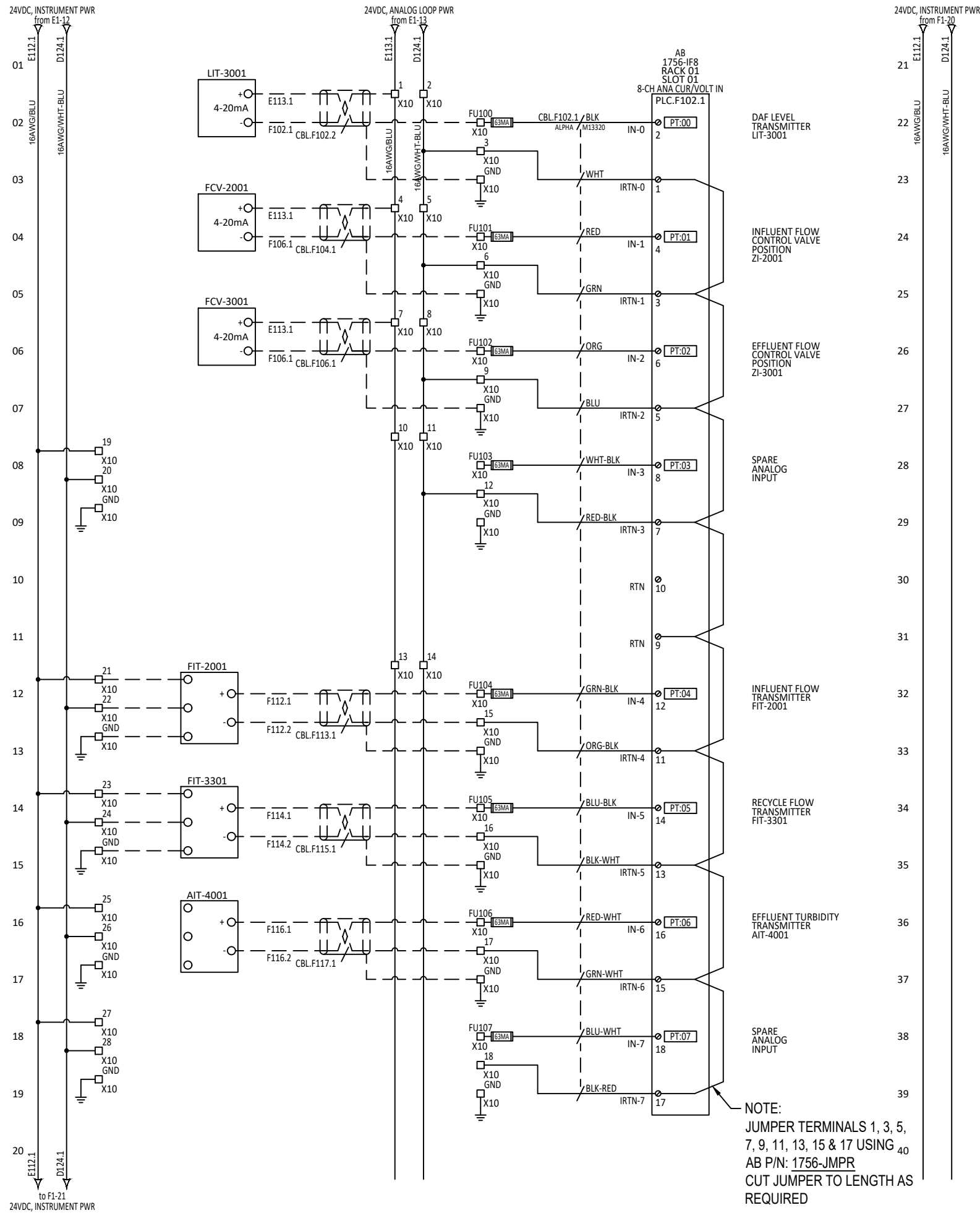

**AUMSVILLE WWTP**  
AUMSVILLE, OR



**Krofta Technologies LLC**  
PO Box 7, 401 South Street, Dalton MA 01227  
Tel: 413.236.5634 Fax: 413.236.6917 info@krofta.com

REV.	DATE	BY	REVISION DESCRIPTION
A	04/15/2025	CFW	FOR REVIEW
A.1	05/29/2025	CFW	UPDATED PER CUSTOMER COMMENTS

SECTION:	DWN BY:	CHK'D BY:	DATE DWN:	PROJECT NUM:
56003EN25_0F01	CFW		04/15/2025	56003EN-25
DRAWING NUM:	SUB SEC:	SHEET:	OF:	REV:
56003EN25_0F01	F	1	2	A.1

ECP-DAF-3001  
ANALOG INPUT

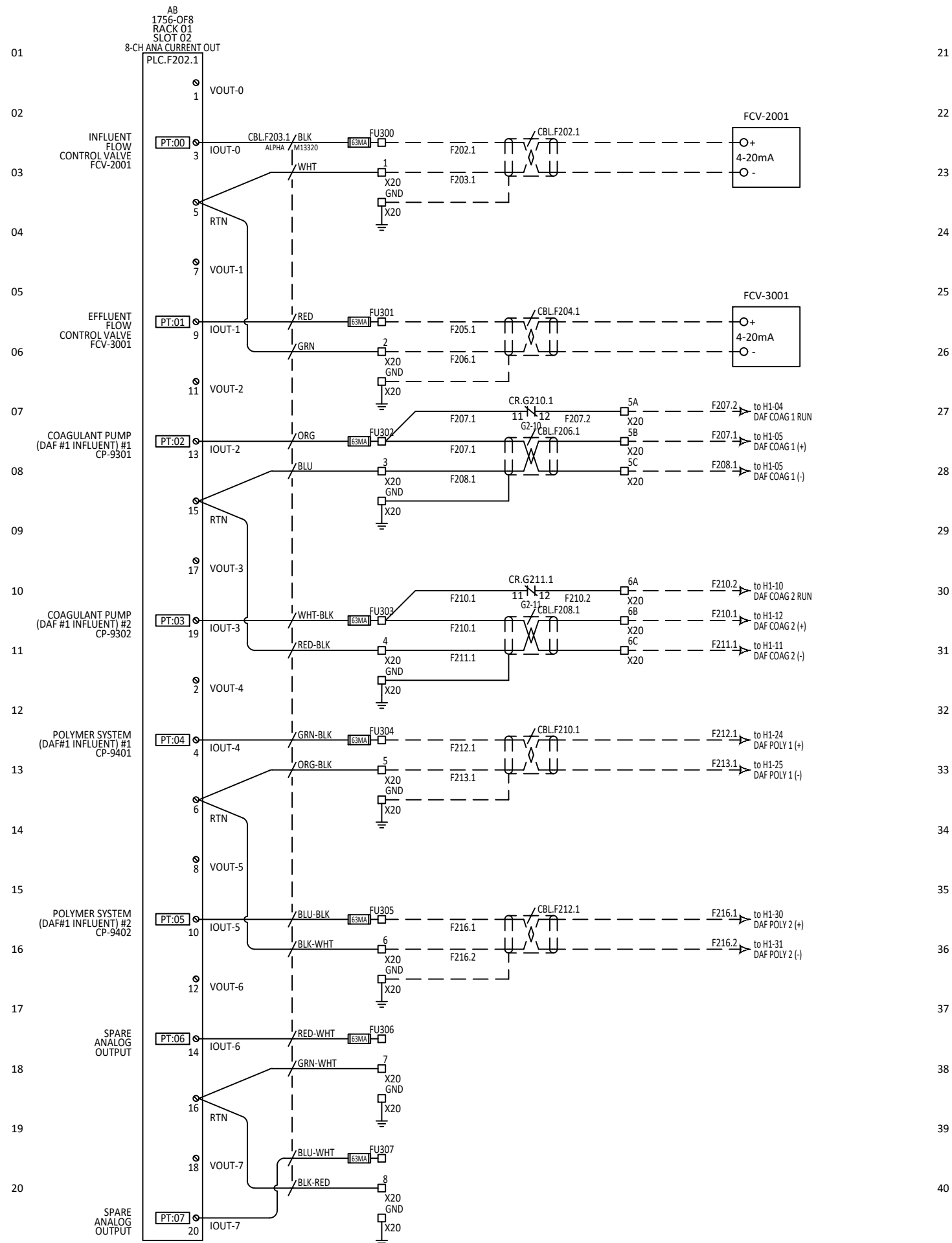

**Krofta Technologies LLC**  
 P.O. Box 7, South Street, Dalton, MA 01227  
 Tel: 413.236.5634 Fax: 413.236.6917 info@krofta.com

**AUMSVILLE WWTP**  
 AUMSVILLE, OR

SECTION:	DWN BY:	CHK'D BY:	DATE DWN:	PROJECT NUM:
DRAWING NUM:	CFW	CFW	04/15/2025	56003EN-25
56003EN25_0F02		F	SHEET:	OF:
			2	2
			REV:	A.1

RELEASED FOR: REVIEW

REV.	DATE	BY	REVISION DESCRIPTION
A	04/15/2025	CFW	FOR REVIEW
A.1	05/29/2025	CFW	UPDATED PER CUSTOMER COMMENTS

ECP-DAF-3001  
ANALOG OUTPUT

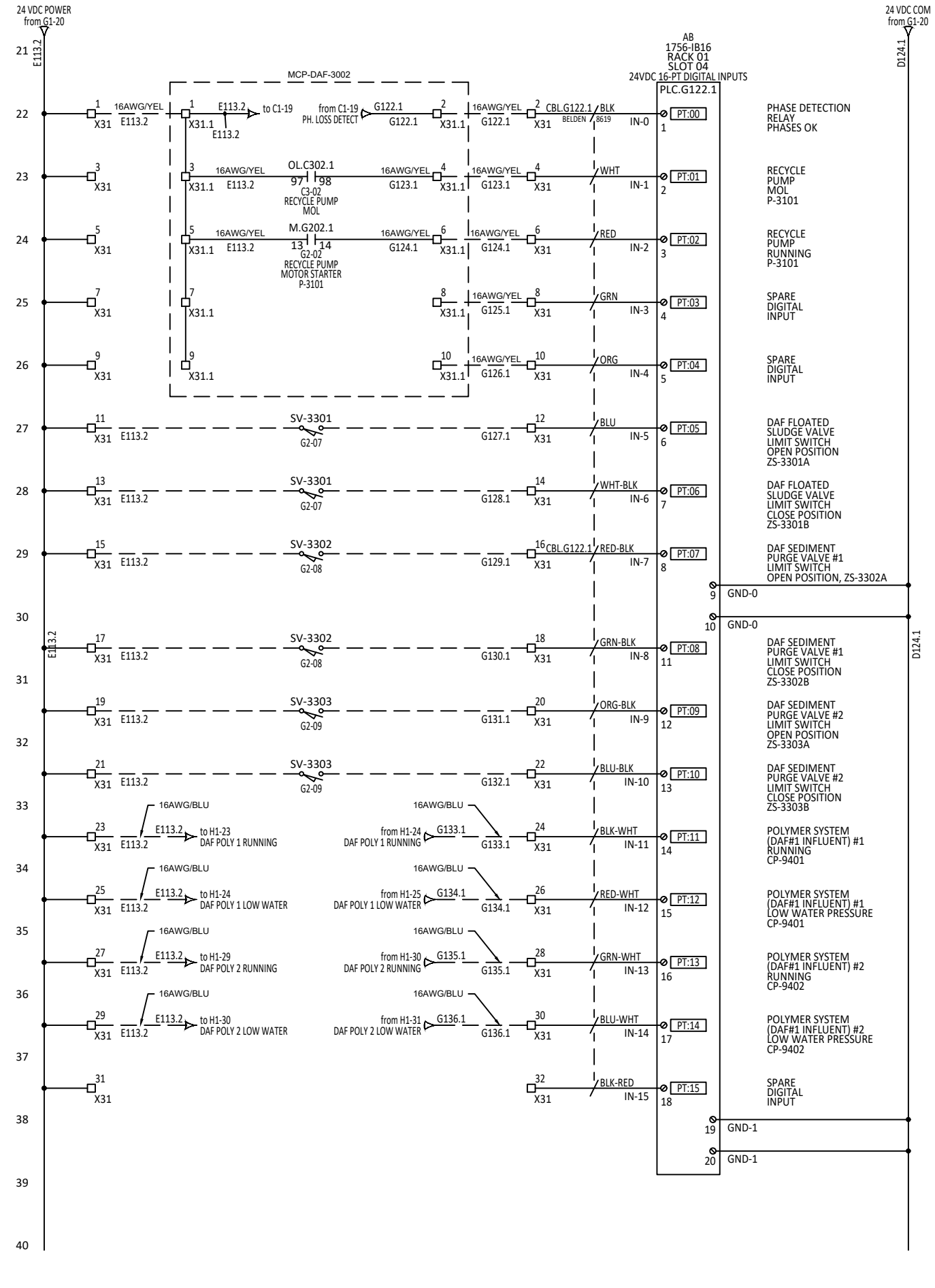
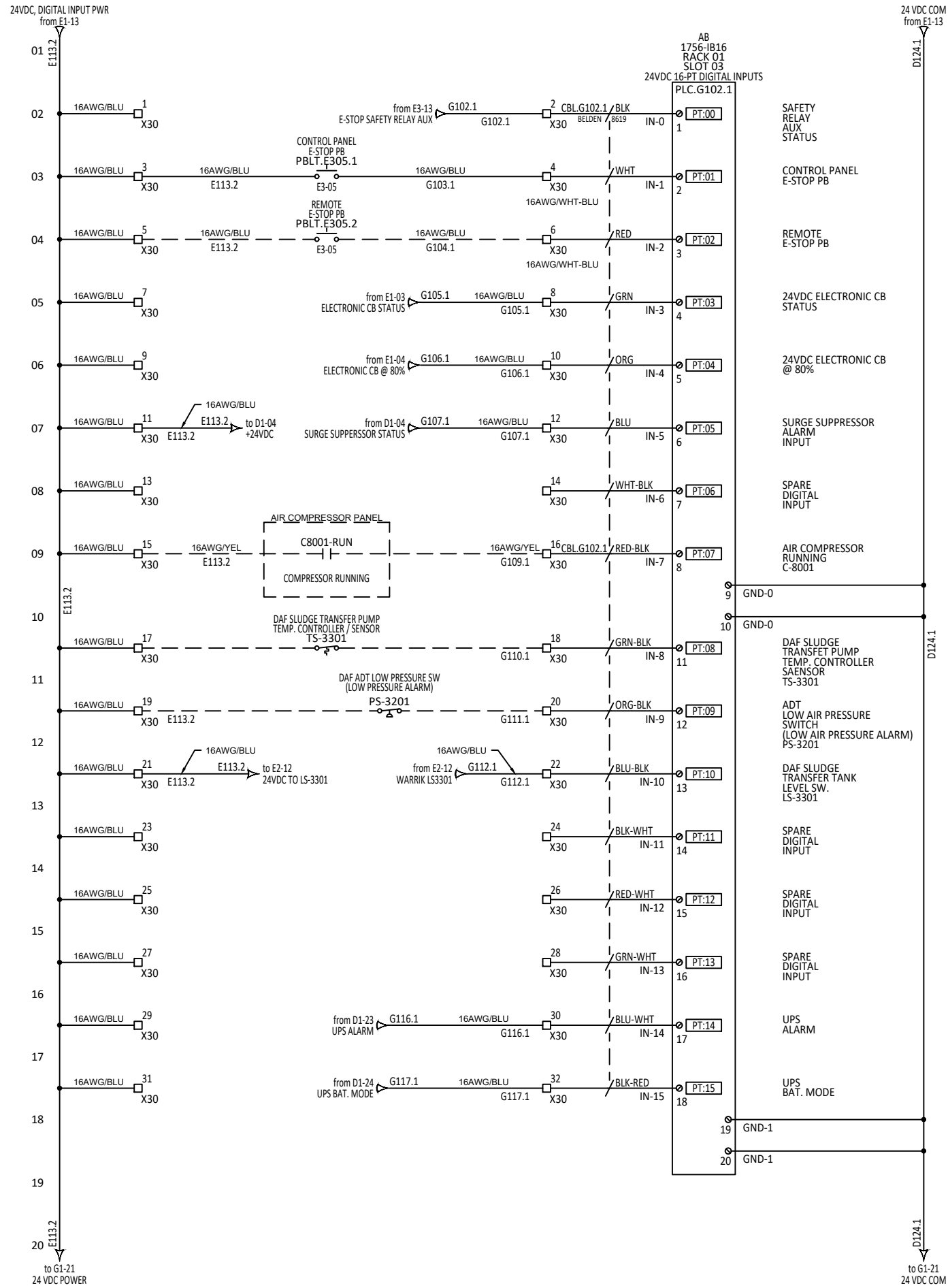

**AUMSVILLE WWTP**  
AUMSVILLE, OR

**KROFTA**  
Krofta Technologies LLC  
PO Box 7 401 South Street Dalton MA 01227  
Tel: 413.236.5634 Fax: 413.236.6917 info@krofta.com

RELEASED FOR: REVIEW

REV.	DATE	BY	REVISION DESCRIPTION
A	04/15/2025	CFW	FOR REVIEW
A.1	05/29/2025	CFW	UPDATED PER CUSTOMER COMMENTS

SECTION:	DWN BY:	CHK'D BY:	DATE DWN:	PROJECT NUM:
DRAWING NUM:	CFW		04/15/2025	56003EN-25
56003EN25		G	SHEET:	OF:
0601			1	2
			REV:	A.1

ECP-DAF-3001  
DIGITAL INPUTS



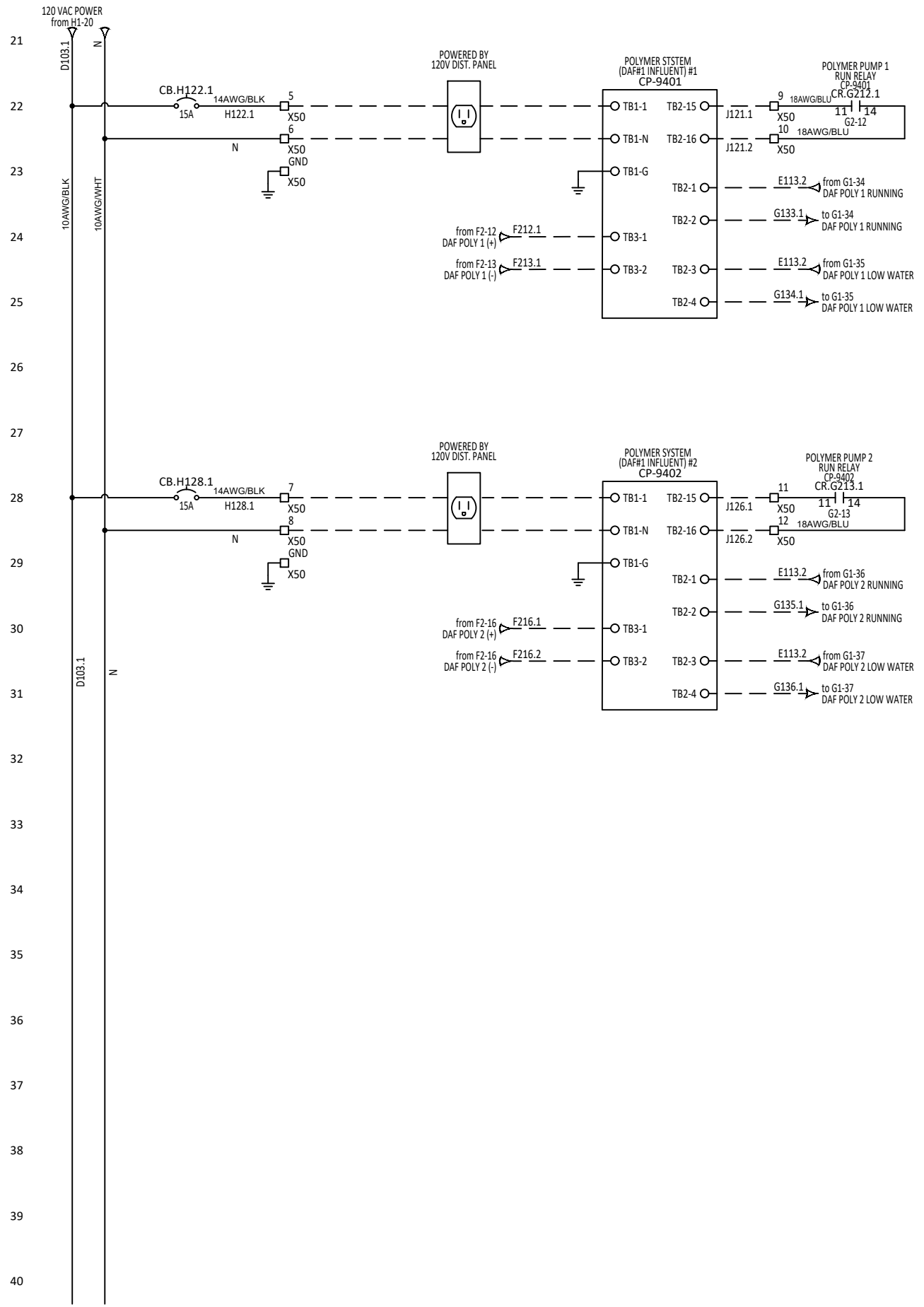
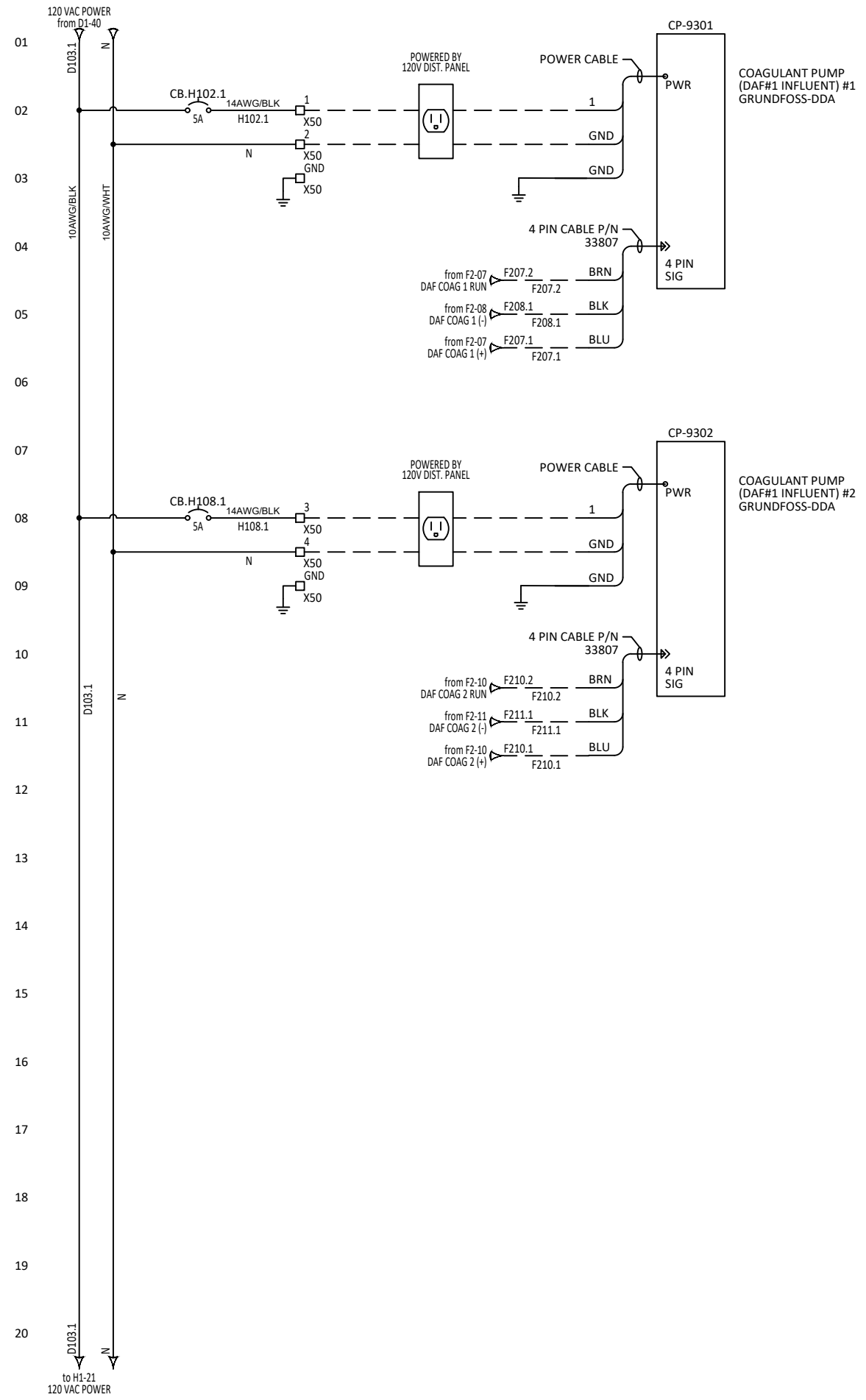

**AUMSVILLE WWTP**  
 AUMSVILLE, OR

RELEASED FOR: REVIEW

REV.	DATE	BY	REVISION DESCRIPTION
A	04/15/2025	CWF	FOR REVIEW
A.1	05/29/2025	CWF	UPDATED PER CUSTOMER COMMENTS

SECTION:	DWN BY:	CHK'D BY:	DATE DWN:	PROJECT NUM:
56003EN25 0H01	CWF	H	04/15/2025	56003EN-25
DRAWING NUM:	SUB SEC:	SHEET:	OF:	REV:
56003EN25 0H01	H	1	1	A.1

CHEMICAL PUMPS