

AMENDMENT OF SOLICITATION/MODIFICATION OF CONTRACT			1. CONTRACT ID CODE N/A	PAGE 1 of 2
2. AMENDMENT/MODIFICATION NO. A002	3. EFFECTIVE DATE 06/01/2026	4. REQUISITION/PURCHASE NO. N/A		5. PROJECT NO. (If applicable) See Blk 14
6. ISSUED BY Department of Transportation Federal Highway Administration 610 East Fifth Street Vancouver WA 98661-3801		CODE N/A	7. ADMINISTERED BY (If other than Item 6) CODE N/A	
8. NAME AND ADDRESS OF CONTRACTOR (No., street, county, State and Zip Code)			X	9A. AMENDMENT OF SOLICITATION NO. 69056726B000001
				9B. DATED (SEE ITEM 11) 05/12/2026
				10A. MODIFICATION OF CONTRACT/ORDER NO. N/A
				10B. DATED (SEE ITEM 13) N/A
CODE: N/A		FACILITY CODE: N/A		

11. THIS ITEM ONLY APPLIES TO AMENDMENTS OF SOLICITATIONS

The above numbered solicitation is amended as set forth in Item 14. The hour and date specified for receipt of Offers

() is extended, () is not extended.

Offers must acknowledge receipt of this amendment prior to the hour and date specified in the solicitation or as amended, by one of the following methods:

(a) By completing Items 8 and 15, and returning 1 copies of the amendment; (b) By acknowledging receipt of this amendment on each copy of the offer submitted; or (c) By separate letter or telegram which includes a reference to the solicitation and amendment numbers. **FAILURE OF YOUR ACKNOWLEDGMENT TO BE RECEIVED AT THE PLACE DESIGNATED FOR THE RECEIPT OF OFFERS PRIOR TO THE HOUR AND DATE SPECIFIED MAY RESULT IN REJECTION OF YOUR OFFER.** If by virtue of this amendment you desire to change an offer already submitted, such change may be made by telegram or letter, provided each telegram or letter makes reference to the solicitation and this amendment, and is received prior to the opening hour and date specified.

12. ACCOUNTING AND APPROPRIATION DATA (If required)

N/A

13. THIS ITEM APPLIES ONLY TO MODIFICATIONS OF CONTRACTS/ORDERS, IT MODIFIES THE CONTRACT/ORDER NO. AS DESCRIBED IN ITEM 14.

A	THIS CHANGE ORDER IS ISSUED PURSUANT TO (Specify authority) THE CHANGES SET FORTH IN ITEM 14 ARE MADE IN THE CONTRACT ORDER NO. IN ITEM 10A. N/A
B	THE ABOVE NUMBERED CONTRACT/ORDER IS MODIFIED TO REFLECT THE ADMINISTRATIVE CHANGES (Such as changes in paying office, appropriation date, etc.) SET FORTH IN ITEM 14, PURSUANT TO THE AUTHORITY OF FAR 43.103(b). N/A
C	THIS SUPPLEMENTAL AGREEMENT IS ENTERED INTO PURSUANT TO AUTHORITY OF: N/A
D	OTHER (Specify type of modification and authority) N/A

E. IMPORTANT: Contractor n/a is not, n/a is required to sign this document and return n/a copies to the issuing office.

14. DESCRIPTION OF AMENDMENT/MODIFICATION (Organized by UCF section headings, including solicitation/contract subject matter where feasible.)

WA NP MORA 11(1), Fryingpan Creek Bridge

See page 2

Except as provided herein, all terms and conditions of the document referenced in Item 9A or 10A, as heretofore changed, remains unchanged and in full force and effect.	
15a. NAME AND TITLE OF SIGNER (Type or print)	15a. NAME AND TITLE OF CONTRACTING OFFICER (Type or print) N/A
15B. CONTRACTOR/OFFEROR	15C. DATE SIGNED
BY _____ (Signature of person authorized to sign)	16B. UNITED STATES OF AMERICA BY <u>N/A</u> (Signature of Contracting Officer)
	16C. DATE SIGNED N/A

REVISIONS ARE AS FOLLOWS:

SF 1442, SOLICITATION, OFFER, AND AWARD

Page A-3, Block 13A. Revises bid opening date from 06/18/2026 to 07/01/2026.

Page A-5, Continuation SF 1442, Block 11. Revises notice to proceed date from 08/04/2026 to 08/25/2026.

PLANS

Plan sheet S.19. Adds weld details to Detail B.

ENCLOSURES

Pages:

A-3

A-5

Plan Sheets:

S.19

SOLICITATION, OFFER, AND AWARD <i>(Construction, Alteration, or Repair)</i>	1. SOLICITATION NO. 69056726B000001	2. TYPE OF SOLICITATION <input checked="" type="checkbox"/> SEALED BID (IFB) <input type="checkbox"/> NEGOTIATED (RFP)	3. DATE ISSUED 05/12/2026	PAGE OF PAGES 1 2	
	IMPORTANT -- The "offer" section on the reverse must be fully completed by offeror.				

4. CONTRACT NO.		5. REQUISITION/PURCHASE REQUEST NO.	6. PROJECT NO. See Blk 10
7. ISSUED BY Federal Highway Administration FHWA WESTERN FED LANDS DIVISION 610 E FIFTH STREET Vancouver WA 98661	CODE 690567	8. ADDRESS OFFER TO Federal Highway Administration FHWA WESTERN FED LANDS DIVISION 610 E FIFTH STREET Vancouver WA 98661	
9. FOR INFORMATION CALL: 	a. NAME See Page A-5	b. TELEPHONE NO. (Include area code) (NO COLLECT CALLS) 360-619-7520	

SOLICITATION**NOTE: In sealed bid solicitations "offer" and "offeror" mean "bid" and "bidder."**

10. THE GOVERNMENT REQUIRES PERFORMANCE OF THE WORK DESCRIBED IN THESE DOCUMENTS (Title, identifying no., date)

This solicitation is designed WA NP MORA 11(1), Fryingpan Creek Bridge

IN STRICT ACCORDANCE WITH:

Federal Acquisition Regulation (FAR) and Transportation Acquisition Regulations (TAR)
 General Wage Decision
 Special Contract Requirements
 Standard Specifications for Construction of Roads and Bridges on Federal Highway
 Projects, FP-14

11. The Contractor shall begin performance within <u>10</u> calendar days and complete it within <u>*</u> calendar days after receiving <input type="checkbox"/> award, <input checked="" type="checkbox"/> notice to proceed. The performance period is <input checked="" type="checkbox"/> mandatory <input type="checkbox"/> negotiable. (See <u>Page A-6</u> .)	12b. CALENDAR DAYS 10
12a. THE CONTRACTOR MUST FURNISH ANY REQUIRED PERFORMANCE AND PAYMENT BONDS? <input checked="" type="checkbox"/> YES <input type="checkbox"/> NO (If "YES", indicate within how many calendar days after award in Item 12b.)	

13. ADDITIONAL SOLICITATION REQUIREMENTS:

a. Sealed offers in original and 0 copies to perform the work required are due at the place specified in Item 8 by 1400 (hour) local time07/01/2026 ~~06/18/2026~~ (date). If this is a sealed bid solicitation, offers will be publicly opened at that time. Sealed envelopes containing offers shall be

marked to show the offeror's name and address, the solicitation number, and the date and time offers are due.

b. An offer guarantee is, is not required.

c. All offers are subject to the (1) work requirements, and (2) other provisions and clauses incorporated in the solicitation in full text or by reference.

d. Offers providing less than 60 calendar days for Government acceptance after the date offers are due will not be considered and will be rejected .

Block 9 **FOR GENERAL INFORMATION**, call **360.619.7520** from the hours of 8:00 a.m. to 4:00 p.m. local time or e-mail us at wfl.contracts@dot.gov.

FOR TECHNICAL INFORMATION (plan and specification questions only), requests for technical information about this project will only be accepted in writing. Submit questions via e-mail at wfl.plans-spec@dot.gov.

QUESTIONS/ANSWERS POSTED ONLINE. You can view questions and answers on the Contract Opportunities Website SAM.gov.

- Insert the solicitation number in search box.
- Scroll to the project.
- Make sure you are on the most recent view and look in the right section of the page for the most recent Q&A document.

FOR DAVIS-BACON WAGE RATE INFORMATION go to the U.S. Department of Labor, Branch of Construction Wage Determinations Website: <https://www.dol.gov/agencies/whd/government-contracts/construction>.

FOR PHYSICAL DATA, See Subsection 102.02A in the Special Contract Requirements for listing of available data. Physical Data will be posted with the solicitation on the SAM.gov website.

Block 11 **COMPLETION DATE:** The Contractor shall be required to (a) commence work under this contract within 10 calendar days after the date the Contractor receives the notice to proceed, (b) prosecute the work diligently, and (c) complete the entire work ready for use not later than **09/28/2029** for Schedule A and B, subject to such extensions as may be authorized. The time stated for completion shall include final cleanup of the premises. The completion date is based on the assumption that the successful offeror will receive the notice to proceed by ~~08/04/2026~~ **08/25/2026** for Schedule A and B. The completion date will be extended by the number of calendar days after the above date that the Contractor receives the notice to proceed, except to the extent that the delay in issuance of the notice to proceed results from the failure of the Contractor to execute the contract and give the required performance and payment bonds within the time specified in the offer.

Work shall be completed on or before the date specified above, subject to such extensions as may be authorized by the terms of the contract and the specifications made a part thereof.

Block 12A **PERFORMANCE & PAYMENT BONDS:** See FAR Clause, 52.228-15, *Performance and Payment Bonds - Construction* (clauses begin on page C-1) and Subsection 102.06 of the *Standard Specifications for Construction of Roads and Bridges on Federal Highway Projects, FP-14, U.S. Customary Units*.

Block 13A **BID OPENING:** Video call link: <https://meet.google.com/xgh-hthy-edi> Or dial: (US) +1 304-405-6237 PIN: 983 639 621#

Revised by Amendment A002

STATE	PROJECT	SHEET NUMBER
WA	NP MORA 11(1)	S.19

ACTUAL FILE: S.12_MORA 11(1)_BEARING_DET.S.DGN

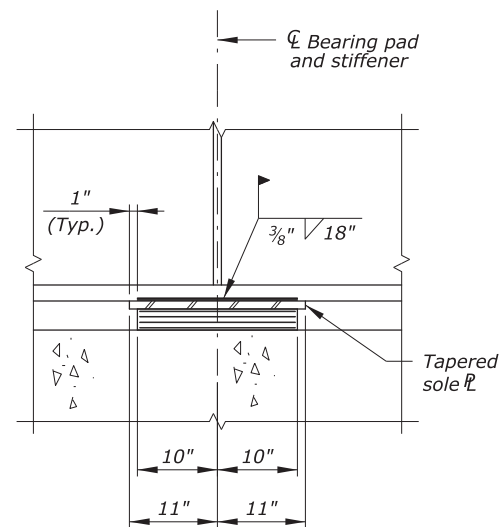

SECTION A-A
Scale: 1" = 1'-0"

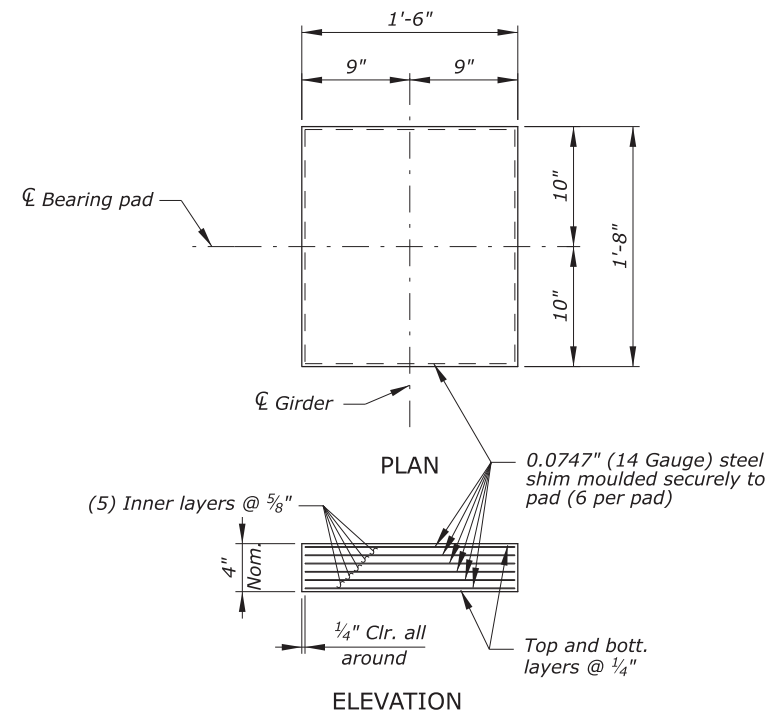

ABUT. ELASTOMERIC BEARING PAD
Scale: 1 1/2" = 1'-0"

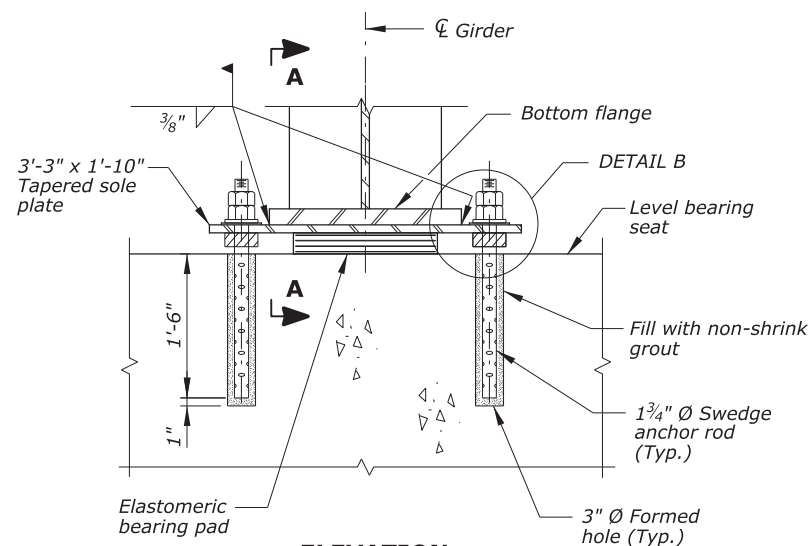

ELEVATION
Scale: 1" = 1'-0"

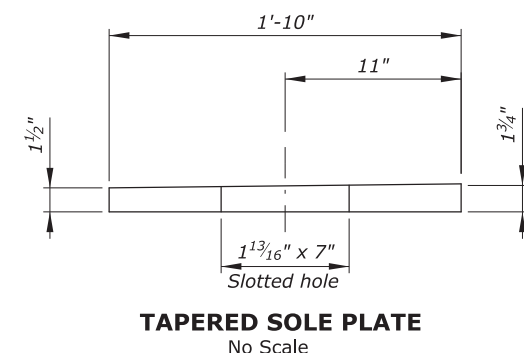

TAPERED SOLE PLATE
No Scale

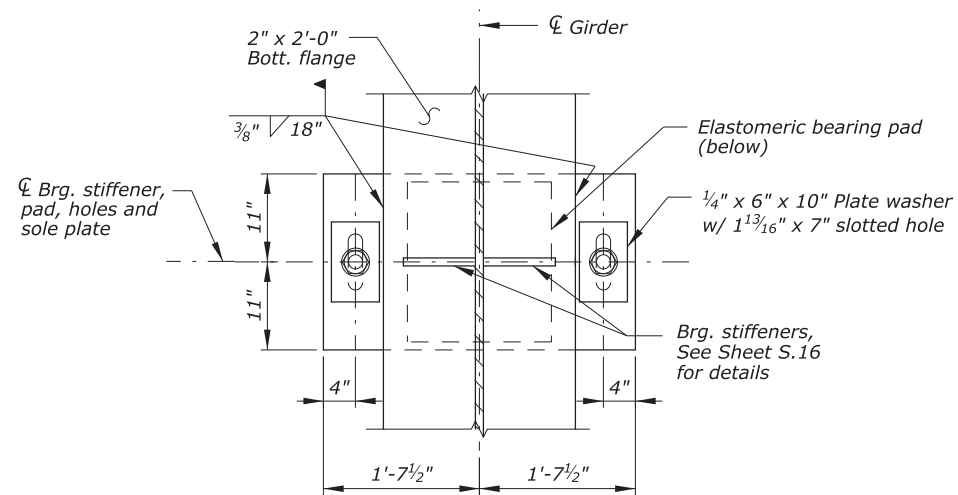

ELEVATION
(8 Req'd)
Scale: 1" = 1'-0"

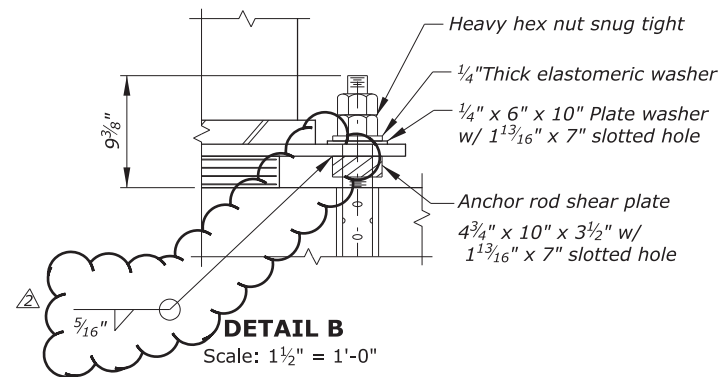

DETAIL B
Scale: 1 1/2" = 1'-0"

Notes:

1. Furnish AASHTO M 270, Grade 50W sole plates and anchor rod shear plates.
2. Conform to AASHTO M 251 for steel reinforced elastomeric bearing pads. Provide 60 Durometer hardness, elastomer Grade 5.
3. Conform to ASTM F1554, Grade 105 for anchor rods including supplementary charpy V-notch test criteria, S4. Conform to ASTM A563, Grade DH or DH3 for heavy hex nuts. Galvanize rods and nuts.
4. Vulcanize elastomeric pad to bottom surface of sole plate.
5. Mark all bearings prior to shipping. Include the bearing location on the bridge and a direction arrow pointing ahead of installation.

U.S. DEPARTMENT OF TRANSPORTATION
FEDERAL HIGHWAY ADMINISTRATION
WESTERN FEDERAL LANDS HIGHWAY DIVISION

MOUNT RAINIER NATIONAL PARK

FRYINGPAN CREEK BRIDGE

BEARING DETAILS

NO.	DATE	BY	REVISIONS	NO.	DATE	BY	REVISIONS	DESIGNED BY	DRAWN BY	CHECKED BY	SCALE	PROJECT TEAM LEADER	BRIDGE DRAWING	DATE	DRAWING NO.
1	5/28/26	BAO	Added weld details to Detail B					Y.Qi	J. Galdos	P. Clark	As shown	B. Oltmann	19 of 46	April 2026	RG3283-S