

Metro Transit - University Bridge Trolley Pole Replacement

Contract KC001609

FTA Grant No. WA-2024-052-00 (APP 1731-2024-8)

Volume 3 of 3

Contract Drawings

February 2026



King County

Metro Transit Department
Capital Division

LOCATION MAP
NOT TO SCALE

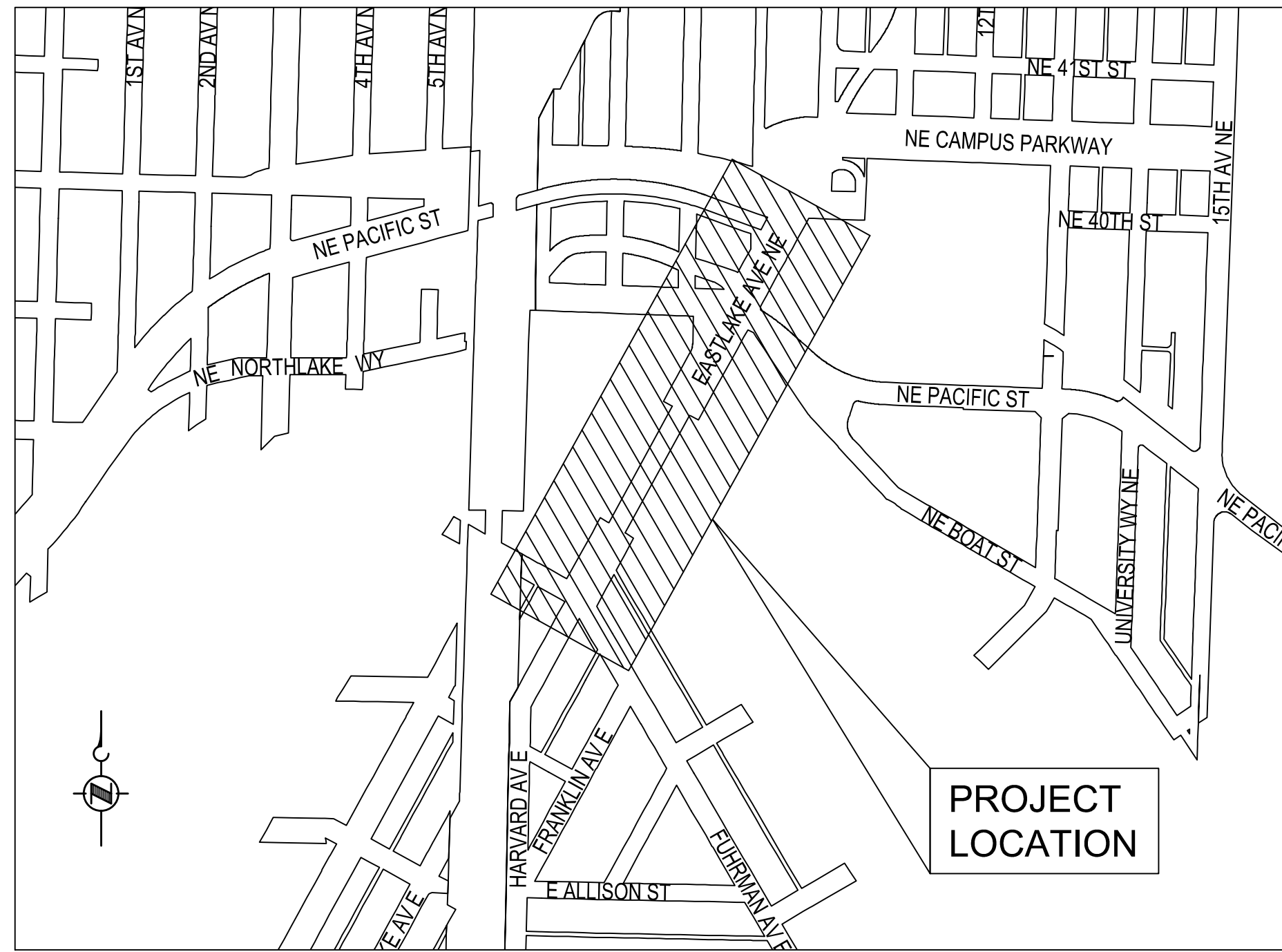

VICINITY MAP
NOT TO SCALE

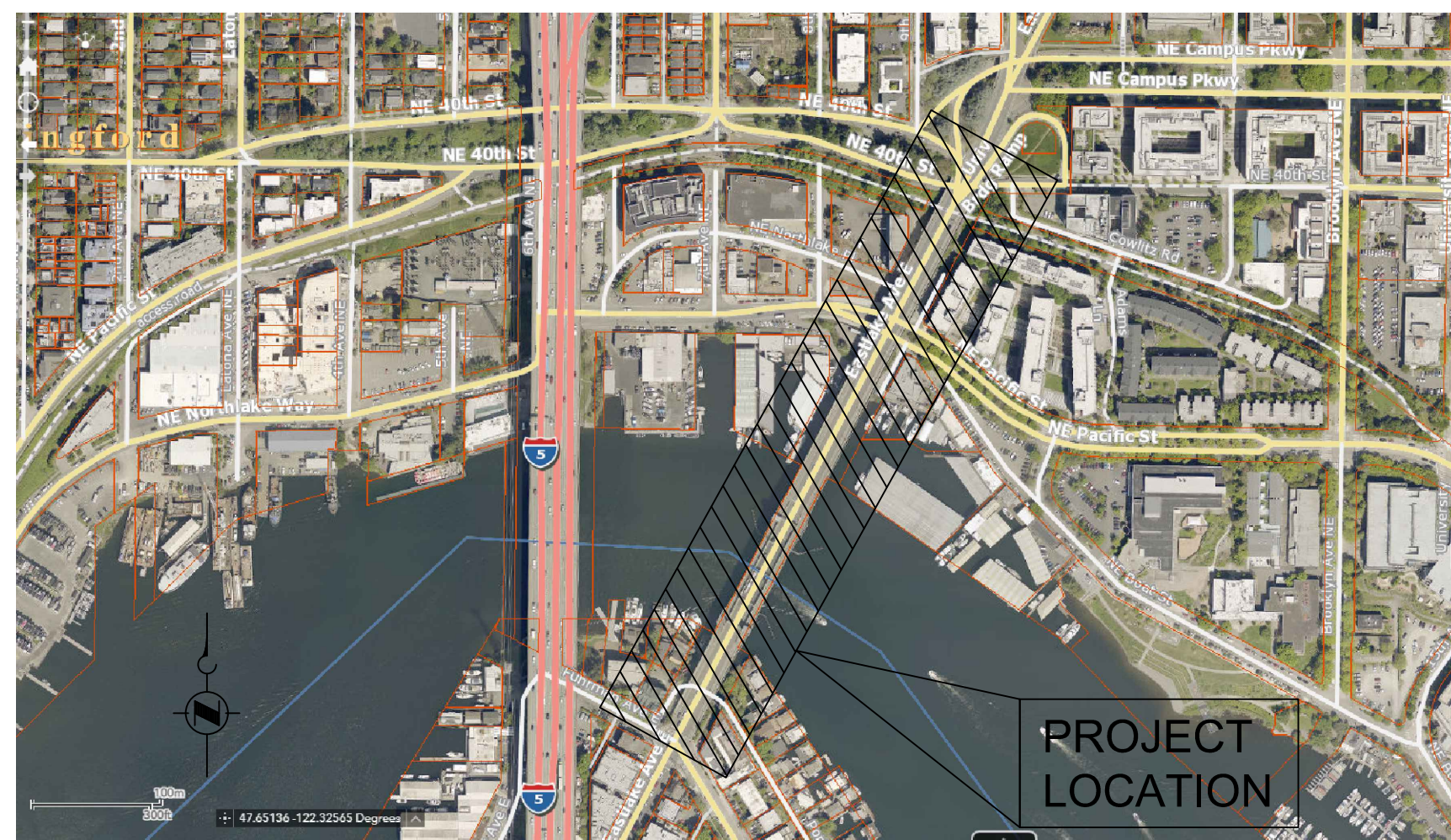
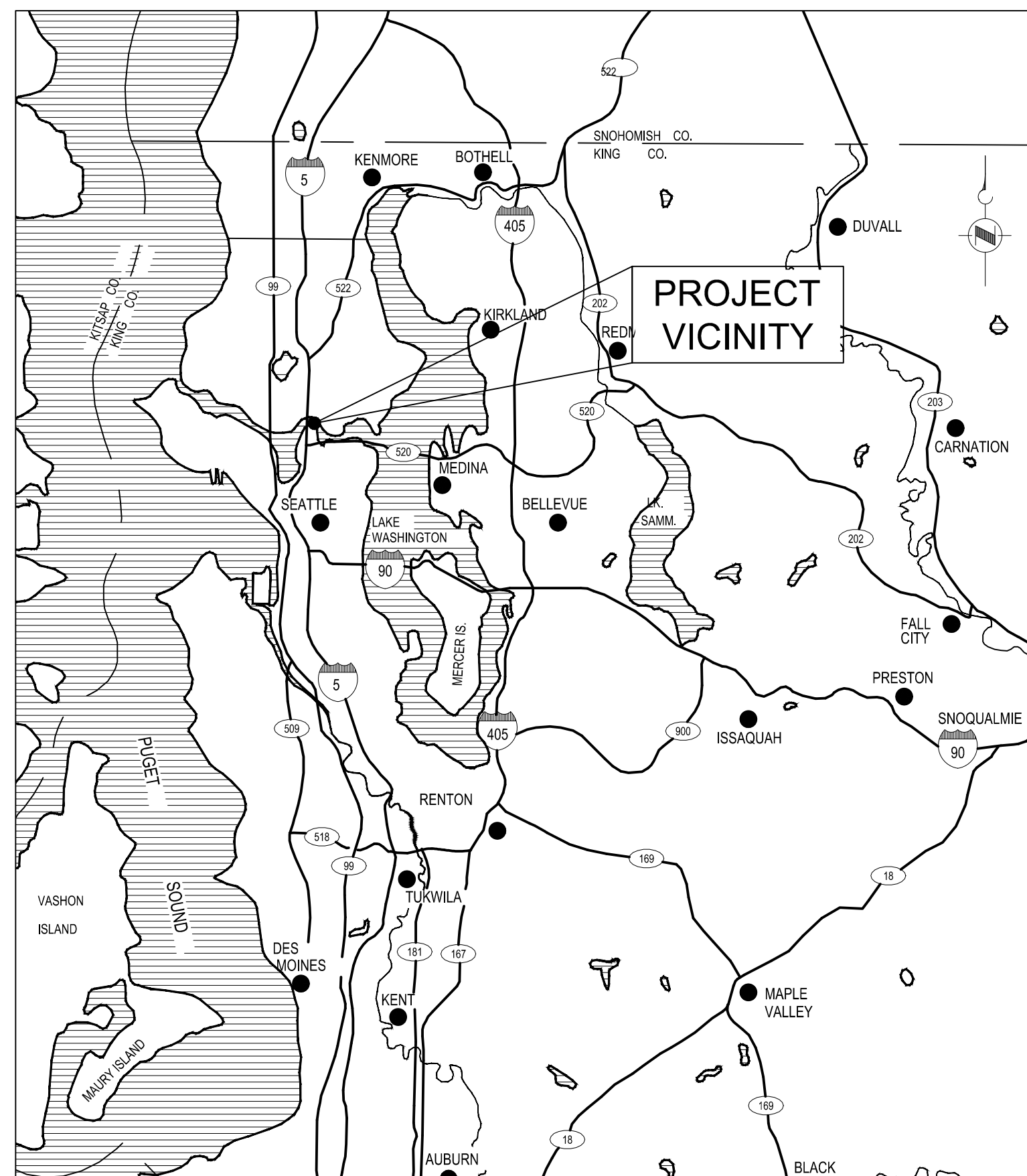

SHEET INDEX

SHEET NO.	DRAWING NUMBER	DRAWING NAME
1	G0.01	COVER
2	G0.02	GENERAL NOTES - 1
3	G0.03	GENERAL NOTES - 2
4	ST1.01	PLAN AND ELEVATION - 1
5	ST1.02	PLAN AND ELEVATION - 2
6	ST1.03	PLAN AND ELEVATION - 3
7	ST1.04	PLAN AND ELEVATION - 4
8	ST3.01	TYPICAL SECTIONS
9	ST3.02	BRIDGE FRAMING PLAN
10	ST5.01	POLE FOUNDATION DETAILS ON STEEL BRIDGE SPANS (TYPE A)
11	ST5.02	POLE FOUNDATION DETAILS ON CONCRETE BRIDGE SPANS (TYPE B)
12	ST5.03	POLE SHAFT FOUNDATION DETAILS - 1
13	ST5.04	POLE SHAFT FOUNDATION DETAILS - 2
14	ST5.05	POLE ANCHOR PLATE AND BASE PLATE DETAILS
15	ST5.06	POLE INSTALLATION DETAILS
16	ST5.07	FEEDER POLE DETAILS
17	ST5.08	SUPERBENT POLE MOUNTING DETAILS - 1
18	ST5.09	SUPERBENT POLE MOUNTING DETAILS - 2
19	ST5.10	SUPERBENT POLE MOUNTING DETAILS - 3
20	ST5.11	SUPERBENT POLE MOUNTING DETAILS - 4
21	ST5.12	SUPERBENT POLE MOUNTING DETAILS - 5
22	ST5.13	SUPERBENT POLE MOUNTING DETAILS - 6
23	ST5.14	STEEL POLE SIDEWALK GUY DETAILS
24	ST5.15	WOOD POLE DOWN GUY DETAILS
25	ST5.16	POLE SPECIFICATIONS - 1
26	ST5.17	POLE SPECIFICATIONS - 2
27	ST6.01	TROLLEY POLE REPLACEMENT SCHEDULE
28	CSP.01	CONSTRUCTION SEQUENCE
29	CSP.02	CONSTRUCTION SEQUENCE STAGE 2 - 1
30	CSP.03	CONSTRUCTION SEQUENCE STAGE 2 - 2
31	CSP.04	CONSTRUCTION SEQUENCE STAGE 3 - 1
32	CSP.05	CONSTRUCTION SEQUENCE STAGE 3 - 2
33	C1.01	SOUTH END PAVEMENT RESTORATION PLAN
34	C1.02	NORTH END PAVEMENT RESTORATION PLAN
35	C1.03	SOUTH END EROSION AND SEDIMENT CONTROL PLAN
36	C1.04	NORTH END EROSION AND SEDIMENT CONTROL PLAN
37	ET1.01	OCS FEEDER SPAN CONDUIT REPLACEMENT PLAN
38	ET1.02	OCS FEEDER SPAN CONDUIT REPLACEMENT DETAILS
39	ET1.03	LIGHTING CONDUIT REPLACEMENT PLAN
40	ET1.04	LIGHTING CONDUIT REPLACEMENT DETAILS
41	ET1.05	OCS TEMPORARY FEEDER SOUTH END
42	ET1.06	OCS TEMPORARY FEEDER NORTH END
43	ET1.07	OCS FEEDER CABLE SUPPORT DETAILS

METRO UNIVERSITY BRIDGE TROLLEY POLE REPLACEMENT KING COUNTY

Z:\210127 KC University Pole Replacement\CAD\SHEET 1 G0.01 COVER.dwg | Layout: G1.01
 PLOTTED: Dec 11, 2025 10:40:38am By Jane Work
 XREFS: KC DC-BORDER-RHC Engineering IMAGES

No.	REVISION	BY	APP'D	DATE

ONE INCH

 AT FULL SCALE

RHC ENGINEERING
 WWW.RHCENGINEERING.COM
 720 3RD AVE SUITE 1400
 SEATTLE WA 98104
 PH: 206.623.5984

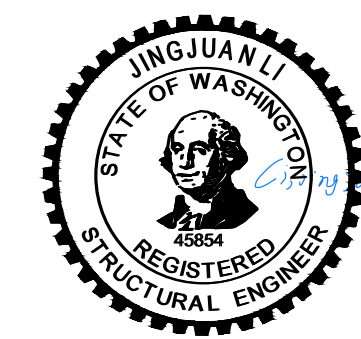

DESIGNED: J. LI	APPROVED: G. FRANCO
DRAWN: T. LOZADA	PROJECT NO: 1127254
CHECKED: G. CHEN	CONTRACT NO: -
CHECKED: -	



METRO TRANSIT CAPITAL DIVISION
 TROLLEY OVERHEAD SYSTEM
 UNIVERSITY BRIDGE TROLLEY POLE REPLACEMENT











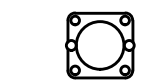
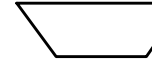

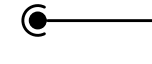
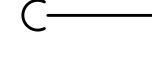
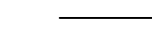



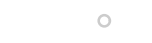

COVER

DRAWING NO:
G0.01

SHEET NO. OF
1 OF 43

DATE: DECEMBER 2, 2025
DRAWING NO: G0.01
SHEET NO. OF 1 OF 43

LEGEND

-  NEW ANCHOR BASE STEEL POLE
-  NEW ANCHOR BASE STEEL POLE WITH FEEDER CONDUIT
-  CURB FOUNDATION
-  SHAFT FOUNDATION
-  SIDEWALK GUY ON POLE
-  DOWN GUY ON POLE
-  NEW SPAN WIRE
-  EX. TROLLEY WIRE, NEGATIVE (DOUBLE LINE) POSITIVE
-  EXISTING SPAN WIRE
-  EXISTING DIRECT EMBEDMENT STEEL TROLLEY POLE
-  EXISTING TROLLEY POLE
-  EXISTING TROLLEY/LIGHT POLE
-  EXISTING STORM DRAIN
-  EXISTING BOLLARD
-  EXISTING HANDHOLE
-  EXISTING BUILDING EYEBOLT
-  EXISTING YARD LIGHT
-  EXISTING TREE (CONIFER)
-  EXISTING TREE (DECIDUOUS)
-  EX. UNDERGROUND WATER LINE
-  EX. UNDERGROUND GAS LINE
-  EX. UNDERGROUND ELECTRICAL
-  EX. TELEPHONE LINES
-  EX. PROPERTY BOUNDARY

ABBREVIATIONS:

- ASPH ASPHALT PAVEMENT
 - BMP BEST MANAGEMENT PLAN
 - EX EXISTING
 - MIN MINIMUM
 - S/W SIDEWALK
 - STA STATIONING
 - TYP. TYPICAL
 - DC DIRECT CIRCUIT
 - PPE PERSONAL PROTECTIVE EQUIPMENT
-
- M METRO TROLLEY
 - SL STREET LIGHTING
 - PL PEDESTRIAN LIGHT
 - SN SIGN
 - F TROLLEY FEEDER POLE
- } PRESENTED IN VARIOUS JOINT USE POLE COMBINATIONS

TYPICAL SECTION AND DETAIL REFERENCING SYSTEM

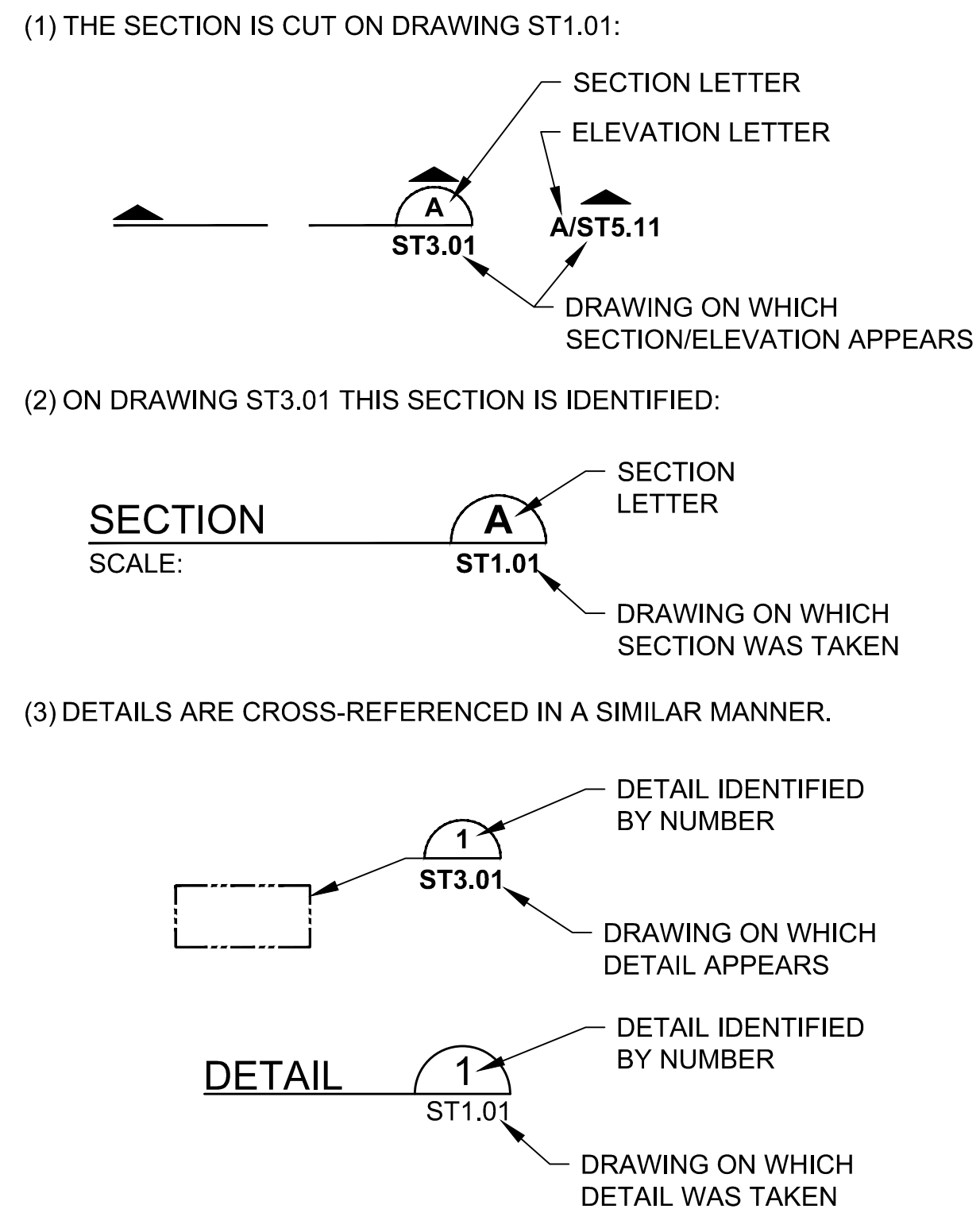

WORK DESCRIPTION:

WORK INCLUDES BUT IS NOT LIMITED TO REPLACE 30 EXISTING TROLLEY AND LIGHTING JOINT USE POLES, AND ADD TWO NEW POLES ON THE EXISTING SUPERBENT BETWEEN PIERS 14 AND 15, ON THE UNIVERSITY BRIDGE. WORK WILL INCLUDE AND BE NOT LIMITED TO TRAFFIC CONTROL, TEMPORARY FEATURES INSTALLATION AND REMOVAL INCLUDING POLES AND SUPPORTS, TEMPORARY OCS POWER FEEDER CALBES, EX. POLES REMOVAL, POLE BASE CURB CONCRETE REMOVAL AND REPLACEMENT, FOUNDATION SHAFT CONSTRUCTION, ANCHOR BOLT AND BASE PLATE INSTALLATION, TROLLEY POLES INSTALLATION, LUMINAIRE AND POWER ELECTRICAL CONDUIT REPLACEMENT, EX. TRAFFIC DEVICE REMOVAL AND INSTALLATION.

SPECIAL INSPECTION REQUIREMENTS:

CONTRACTOR SHALL SUBMIT WORK PLAN FOR ENGINEER'S APPROVAL PRIOR TO CONSTRUCTION AND SHALL HAVE THE FOLLOWING FINISHED WORK INSPECTED BY THE KING COUNTY PROJECT REPRESENTATIVE PRIOR TO THE NEXT STEP OF CONSTRUCTION:

1. TEMPORARY DEADEND POLE AND DOWN GUY/SIDEWALK GUY CONSTRUCTION
2. INSTALLATION, INSPECTION, AND ENERGIZATION OF TEMPORARY FEEDERS SHALL BE COMPLETED PRIOR TO REMOVAL OF ANY EXISTING FEEDER INFRASTRUCTURE, REFER TO DRAWINGS ET1.05 AND ET1.06.
3. EXISTING OCS FEEDER CONDUIT REMOVAL
4. EXISTING POLE FOUNDATION CURB CONCRETE REMOVAL AND EXISTING SHAFT REMOVAL, DRAWINGS ST5.01 - ST5.03.
5. PLACEMENT OF LIGHTING NEW CONDUITS, REINFORCEMENT, AND ANCHOR BOLTS PRIOR TO CONCRETE POUR, DRAWINGS ET1.03 - ET1.04.
6. POLE FOUNDATIONS CONCRETE POUR
7. NEW TROLLEY POLE INSTALLATION, DRAWING ST5.06
8. NEW FEEDER CONDUITS AND PULL BOX PLACEMENT, DRAWINGS ET1.01 TO ET1.02.
9. TEMPORARY FEEDER CABLES, TEMPORARY POLES, AND DOWN GUYS REMOVAL AFTER THE NEW FEEDER AND OCS SYSTEM IS INSTALLED AND ENERGIZED.

GENERAL NOTES

1. TROLLEY OVERHEAD CONSTRUCTION WILL BE PERFORMED BY KING COUNTY IN ACCORDANCE WITH METRO TROLLEY STANDARDS, CURRENT VERSION.
2. POLE FOUNDATION REPLACEMENT CONSTRUCTION SHALL BE IN ACCORDANCE WITH CITY OF SEATTLE 2023 STANDARD SPECIFICATIONS FOR ROAD, BRIDGE, AND MUNICIPAL CONSTRUCTION, AND THE SEATTLE DEPARTMENT OF TRANSPORTATION DIRECTOR'S RULE 01-2017 FOR STREET AND SIDEWALK PAVEMENT OPENING AND RESTORATION.
3. CONTRACTOR SHALL FIELD VERIFY POLE LOCATIONS FOR UTILITY CONFLICTS AND EXISTING BRIDGE CONDITIONS BEFORE CONSTRUCTION. CONTRACTOR SHALL NOTIFY THE KING COUNTY PROJECT REPRESENTATIVE IMMEDIATELY FOR ANY CONFLICT OR DISCREPANCIES PRIOR TO CONSTRUCTION. CALL 811 TO LOCATE UTILITIES BEFORE EXCAVATION.
4. CONTRACTOR SHALL PROTECT IN PLACE ALL EXISTING UTILITIES AND OTHER FEATURES UNLESS OTHERWISE SPECIFIED IN PLAN. RESTORATION OF SUCH DAMAGE SHALL BE AT CONTRACTOR'S OWN EXPENSE.
5. IF TROLLEY CONTACT WIRES ARE IN THE VICINITY OF THE WORK AND STAGING AREA, COORDINATE ANY WIRE MOVEMENT OR DE-ACTIVATION TO ACCOMMODATE CONSTRUCTION WITH TROLLEY IMPACTS (206-477-1150). WORK WITHIN 10 FEET OF ENERGIZED TROLLEY WIRE IS ALLOWED ONLY FOR PERSONNEL CERTIFIED TO WORK ON VOLTAGES 700 OR HIGHER. SEE PROJECT SPECIFICATION SECTION 011000. PER WAC 296-155, ALL NON-QUALIFIED PERSONNEL AND EQUIPMENT MUST MAINTAIN 10 FEET CLEARANCE FROM THE OVERHEAD TROLLEY CONTACT WIRES.
6. CONTRACTOR SHALL PROVIDE SUFFICIENT ADVANCE NOTICE TO THE KING COUNTY PROJECT REPRESENTATIVE IN ORDER TO HAVE FOLLOWING STEPS/ITEMS INSPECTED WITHIN FIVE DAYS AFTER CONSTRUCTION: EXCAVATION, REINFORCING BAR CAGE, ANCHOR BOLTS, GROUNDING, POURING OF CONCRETE, AND POLE INSTALLATION BEFORE ANY ATTACHMENT IS MADE. CONTRACTOR TO PROVIDE ALL TRAINING AND PPE FOR INSPECTORS AND EQUIPMENT TO INSPECT THE WORK UNDERSIDE OF THE BRIDGE.
7. PROTECT ALL EXISTING STRAIN POLES THAT ARE NOT TO BE REPLACED ON SITE.
8. CONTRACTOR SHALL FIELD VERIFY UTILITIES CONFLICT BEFORE EXCAVATION FOR EACH POLE FOUNDATION ON GROUND.
9. ALL UTILITIES SHALL BE PROTECTED IN PLACE, NOTIFY THE KING COUNTY PROJECT REPRESENTATIVE IMMEDIATELY IF UTILITY CONFLICTS OCCUR. CONTRACTOR IS RESPONSIBLE FOR RESTORING UTILITIES DAMAGED FROM CONSTRUCTION.
10. CONTRACTOR SHALL FIELD VERIFY ALL DIMENSIONS AND CONDITIONS PRIOR TO START OF WORK.
11. POLE STATION AND OFFSET ARE FOR ALIGNMENT ALONG THE UNIVERSITY BRIDGE ALIGNMENT. LT OR RT ARE FOR LEFT OR RIGHT SIDE OFFSET LOOKING AHEAD AT STATION.
12. CONTRACTOR IS REQUIRED TO NOTIFY THE BRIDGE OPERATOR AT (206) 684-4765 AT THE BEGINNING OF EACH WORK SHIFT OF THE TYPE OF WORK THAT IS EXPECTED ON THE BRIDGE.
13. CONTRACTOR SHALL NOT HAVE ANY EQUIPMENT OR MATERIAL AT ANY LOCATION ON THE BRIDGE THAT CAN INTERFERE OR POTENTIALLY FOUL BRIDGE OPERATIONS. NO EQUIPMENT OR MATERIAL MAY BE STORED OR PARKED AT ANYTIME WITHIN THE LIMITS OF THE MOVEABLE BRIDGE. COORDINATE WITH THE REQUIREMENTS OF THE CONTRACT DOCUMENTS.
14. UNLESS SPECIFIED FOR REPLACEMENT, CONTRACTOR MUST SURVEY ALL EX. ATTACHMENTS ON ALL POLES AND STORE THE ATTACHMENTS SAFELY FOR REINSTALLATION AFTER POLE REPLACEMENT. ANY DAMAGED ATTACHMENTS SHALL BE REPLACED WITH NEW ATTACHMENTS AT CONTRACTOR'S EXPENSE.
15. SEE PROJECT SPECIFICATION FOR ADVANCE NOTICE AND COORDINATION REQUIREMENTS FOR METRO TO COMPLETE THE OVERHEAD CONTACT SYSTEM CONNECTION AND ENERGIZE THE FEEDER SPAN.

WARNING! HIGH VOLTAGE OVERHEAD TROLLEY POWER WIRES ARE LOCATED WITHIN AND ADJACENT TO THE WORK ZONE. SEE SPECIFICATIONS FOR REQUIRED SAFETY PROCEDURES.

Z:\210127 KC University Pole Replacement\CADD\SHEET 2-3 G0.02-G0.03 GENERAL NOTES.dwg | Layout: G0.02 PLOTTED: Dec 05, 2025 01:26:06pm By: Jane Work XREFS: KCTDC-BORDER-RHC Engineering IMAGES:

No.	REVISION	BY	APPD	DATE

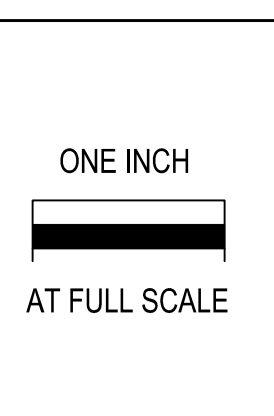

RHC ENGINEERING

WWW.RHCENGINEERING.COM
720 3RD AVE SUITE 1400
SEATTLE WA 98104
PH: 206.623.5984



DESIGNED: J. LI	APPROVED: G. FRANCO
DRAWN: T. LOZADA	PROJECT NO: 1127254
CHECKED: G. CHEN	CONTRACT NO: -
CHECKED: ---	



METRO TRANSIT CAPITAL DIVISION
TROLLEY OVERHEAD SYSTEM
UNIVERSITY BRIDGE TROLLEY POLE REPLACEMENT

GENERAL NOTES - 1

DATE: DECEMBER 2, 2025	DRAWING NO: G0.02
SHEET NO. OF 2	43

POLE AND FOUNDATION NOTES

- POLE AND FOUNDATION ARE DESIGNED IN ACCORDANCE WITH THE FOLLOWING STANDARD:
 - AASHTO LRFD SPECIFICATIONS FOR STRUCTURAL SUPPORTS FOR HIGHWAY SIGNS, LUMINAIRES, AND TRAFFIC SIGNALS, 2015 WITH 2019 INTERIM REVISIONS.
 - AASHTO LRFD BRIDGE DESIGN SPECIFICATIONS, 10TH EDITION
 - CITY OF SEATTLE STANDARD PLANS, 2023 EDITION
 - KING COUNTY METRO STANDARD PLANS SA AND SP SERIES.

CONSTRUCTION SPECIFICATIONS

THE CONTRACTOR MUST PREPARE A CONSTRUCTION STORMWATER AND EROSION CONTROL PLAN (CSECP), A TREE, VEGETATION AND SOIL PROTECTION PLAN (TVSPP) AND A SPILL PLAN (SP) FOR APPROVAL BY THE COUNTY PRIOR TO CONSTRUCTION. SEE PROJECT SPECIFICATION AND THE CITY OF SEATTLE STANDARD SPECIFICATIONS SECTIONS 1-07.15 AND 8-01.

ALL GROUND CONSTRUCTION WORK ON THE BRIDGE SHALL BE IN ACCORDANCE WITH THE FOLLOWING SPECIFICATIONS, UNLESS OTHERWISE NOTED:

- CITY OF SEATTLE STANDARD PLANS FOR MUNICIPAL CONSTRUCTION, 2023 EDITION.
- CITY OF SEATTLE STANDARD SPECIFICATIONS FOR ROAD, BRIDGE, AND MUNICIPAL CONSTRUCTION, 2023 EDITION.
- METRO STANDARD DRAWINGS SA AND SP SERIES.

STRUCTURAL MATERIALS

- CONCRETE STRENGTH: $f_c = 4500$ PSI, UNLESS OTHERWISE NOTED.
- REINFORCING STEEL: ASTM A 706 GRADE 60, $f_y = 60,000$ PSI.
- STRUCTURAL STEEL: ASTM A572 GRADE 50. HOT DIP GALVANIZED.
- STEEL BOLTS: ASTM A325 TYPE I HOT-DIP GALVANIZED
- STEEL ANCHOR BOLTS: ASTM F1554 GRADE 105 IN COMPLIANCE WITH SUPPLEMENTAL REQUIREMENTS S2, S3, AND S4, $F_y = 105$ KSI. HOT DIP GALVANIZED PER ASTM A153.
- STEEL NUTS: ASTM A563 GRADE DH HEAVY HEX STRUCTURAL NUTS. HOT DIP GALVANIZED PER ASTM A153.
- HARDENED STEEL WASHERS AND LOCK WASHERS: ASTM F436. HOT DIP GALVANIZED PER ASTM A153.
- POLYMER MODIFIED CONCRETE: POLYMER MODIFIED CONCRETE SHALL BE EITHER EXPRESS REPAIR BY EUCLID CHEMICAL, SIKAFIX 2500 BY SIKA CORPORATION, OR APPROVED EQUIVALENT. POLYMER MODIFIED CONCRETE SHALL BE INSTALLED PER MANUFACTURER'S RECOMMENDATIONS INCLUDING SURFACE PREPARATION.

TROLLEY OCS FEEDER INFRASTRUCTURE

- TROLLEY OVERHEAD TEMPORARY AND PERMANENT FEEDER CABLE AND SUPPORTING STRUCTURE SHALL BE CONSTRUCTED IN ACCORDANCE WITH METRO TROLLEY STANDARDS DRAWINGS, LATEST VERSION, THE DESIGN DRAWINGS ET1.01 TO ET1.02, AND ET1.05 TO ET1.07, AND THE PROJECT SPECIFICATIONS.

STRUCTURAL NOTES

- THE EXISTING CONDITIONS AND CONDUITS SHOWN ARE FOR REFERENCE ONLY AND MAY NOT REPRESENT ACTUAL FIELD CONDITIONS AND MEASUREMENTS. THE EXISTING FIELD CONDITIONS AND EXISTING CONDUITS THAT AFFECT THE NEW CONSTRUCTION SHALL BE VERIFIED IN FIELD BY THE CONTRACTOR PRIOR TO STARTING ANY WORK.
- THE CONTRACTOR SHALL BE SOLELY RESPONSIBLE FOR ANY DAMAGE TO THE BRIDGE STRUCTURES AND CONDUITS RESULTING FROM THE CONTRACTOR'S OPERATION.
- THE CONTRACTOR SHALL PRESERVE THE EXISTING REBAR ON THE EXISTING BRIDGE WHEN REMOVING CONCRETE UNLESS SPECIFIED IN PLAN FOR CUT AND REMOVAL.
- CONCRETE FINISH REQUIREMENTS
CONCRETE CLEAR COVER OVER REINFORCEMENT MUST BE 3" WHEN CAST AGAINST EARTH, AND 2" AGAINST FORMWORK.
- HOLES DRILLED IN EXISTING CONCRETE MUST BE DRILLED WITH A ROTARY HAMMER.
- UNDERGROUND UTILITIES MAY EXIST IN THE AREA OF CONSTRUCTION. CONTRACTOR IS RESPONSIBLE FOR LOCATING ALL UTILITIES PRIOR TO CONSTRUCTION. CONTRACTOR IS RESPONSIBLE FOR NOTIFYING THE ENGINEER PROMPTLY OF ANY CONFLICT. ALL EXISTING UTILITIES MUST BE PROTECTED IN PLACE UNLESS OTHERWISE NOTED.
- CONTRACTOR MUST BE RESPONSIBLE FOR MAINTAINING THE INTEGRITY OF ADJACENT UTILITIES THAT MAY INCLUDE WATER, SANITARY SEWERS, STORM SEWERS, POWER, TELEPHONE AND CABLE, IRRIGATION, AND STREET LIGHTING.
- IF THE CONTRACTOR DISCOVERS ANY DISCREPANCIES BETWEEN THE PLAN AND THE EXISTING CONDITION ENCOUNTERED, THE CONTRACTOR MUST IMMEDIATELY NOTIFY THE ENGINEER.
- DRAWING MUST NOT BE SCALED FOR CONSTRUCTION PURPOSES. NO LENGTH OF SHAPE IS IMPLIED UNLESS IT IS DIMENSIONED.
- CONTRACTOR MUST AVOID DAMAGE TO EXISTING STEEL REINFORCEMENT DURING DRILLING OPERATIONS. CONTRACTOR MUST NOTIFY KING COUNTY PROJECT REPRESENTATIVE AND ENGINEER IMMEDIATELY IF ANY EXISTING REBAR OR ANCHOR BOLTS ARE DAMAGED. CONTRACTOR MUST LOCATE EXISTING STEEL REINFORCING USING NON-DESTRUCTIVE METHODS.
- ALL UTILITIES MUST BE PROTECTED IN PLACE. CONTRACTOR MUST NOTIFY ENGINEER IF UNIDENTIFIED UTILITY CONFLICTS ARE ENCOUNTERED.
- THE EXISTING DIMENSION, ELEVATIONS, AND STATIONING ON THESE DRAWINGS ARE BASED ON THE AS-BUILT PLANS. THE CONTRACTOR MUST FIELD MEASURE AND VERIFY THESE DIMENSIONS, ELEVATIONS AND STATIONING AS REQUIRED PRIOR TO CONSTRUCTION AND NOTIFY THE ENGINEER IMMEDIATELY OF ANY DISCREPANCIES.
- THE CONTRACTOR MUST BE SOLELY RESPONSIBLE FOR ALL MEANS AND METHODS, SAFETY PRECAUTION, AND CONSTRUCTION PROCEDURES NECESSARY TO PERFORM THE WORK.
- ALL FILLET WELD SIZE SHALL BE 1/4" OR LARGER, UNLESS OTHERWISE NOTED.

STREET LIGHTING GENERAL NOTES:

- ALL DISCONNECTIONS: TEMPORARY OR FINAL SERVICE CONNECTIONS WILL BE MADE BY SEATTLE CITY LIGHT (SCL) AT THE CONTRACTOR'S EXPENSE. COORDINATE ALL ENERGIZING AND DE-ENERGIZING OF STREET LIGHTING SERVICE WITH AN SCL ELECTRICAL SERVICE REPRESENTATIVE AND A STREETLIGHT ENGINEER THIRTY(30) WORKING DAYS IN ADVANCE. ADDITIONAL TIME MAY BE NEEDED FOR CREW SCHEDULING AND MOBILIZATION.
- CONTRACTOR MUST MAKE PRIOR COORDINATION FOR FLOOD OR STREETLIGHT REMOVAL. CONTRACTOR MUST MAKE PRIOR DELIVERY COORDINATION FOR SALVAGED STREETLIGHT-RELATED MATERIALS TO SEATTLE CITY LIGHT SALVAGE YARD AT 4TH AVE S & S SPOKANE ST, 98134. CONTACT SALVAGE COORDINATOR AT 206-386-1765. NO ARTERIAL STREETLIGHTS MAY BE DISABLED WITHOUT PRIOR APPROVAL FROM SEATTLE DEPARTMENT OF TRANSPORTATION, (SDOT).
- EXISTING STREET LIGHTING SYSTEM SHALL BE MAINTAINED DURING CONSTRUCTION. CONTRACTOR SHALL PROVIDE TEMPORARY LIGHTING WHEN NEEDED.
- WORK MUST BE SCHEDULED SUCH THAT NO TWO (2) ADJACENT OR OPPOSITE STREETLIGHTS ARE DISABLED AT ANY ONE TIME.
- ANY EXCAVATION IN PROXIMITY TO AN EXISTING STREETLIGHT POLE MUST BE DONE WITHOUT UNDERMINING ITS STABILITY. CONTRACTOR IS RESPONSIBLE FOR TEMPORARY STABILIZING SUPPORT.
- INSTALLATION OF UNDERGROUND STREETLIGHT SYSTEMS, AND STREETLIGHT SYSTEM GROUNDING AND BONDING MUST BE PER SEATTLE CITY LIGHT (SCL) CONSTRUCTION STANDARD 1714.50.
- ALL WIRING, INCLUDING STREET LIGHTING, PEDESTRIAN LIGHTING AND FESTOON LIGHTING CIRCUITS MUST BE CLEARLY LABELED PER SEATTLE CITY LIGHT (SCL) CONSTRUCTION STANDARD 1714.10.
- EACH LUMINAIRE MUST BE FUSED PER (SCL) CONSTRUCTION STANDARD 1730.00.
- STREETLIGHT HANDHOLE AND CONDUIT REQUIREMENTS MUST CONFORM TO SCL CONSTRUCTION STANDARD 1716.07.
- PULL TAPE MUST BE INSTALLED THROUGH VACANT CONDUIT CAPPED PER (SCL) CONSTRUCTION STANDARD U2-11.40/NDK-40.
- MAINTAIN MINIMUM HORIZONTAL & VERTICAL CLEARANCES BETWEEN SCL UNDERGROUND STRUCTURES AND VARIOUS OTHER UTILITY STRUCTURES PER SCL CONSTRUCTION STANDARD 0214.00.
- FOR STREET LIGHTING INSPECTIONS CONTACT AN SCL ELECTRICAL REVIEWER THIRTY(30) WORKING DAYS IN ADVANCE.
- CONTRACTOR MUST CALL FOR AN ELECTRICAL REVIEWER INSPECTION OF THE STREET LIGHTING SYSTEM AT VARIOUS STAGES OF INSTALLATION/CONSTRUCTION OR AS INSTRUCTED BY THE SCL INSPECTOR.
- CONTRACTOR MUST PROVIDE AN OPERATOR AND MAN LIFT TRUCK FOR USE DURING INSPECTION OF INSTALLED STREETLIGHT FACILITIES.
- CONTRACTOR MUST ASSIST THE INSPECTOR DURING INSPECTIONS, COMMISSIONING, AND FINAL CONNECTION PHASES OF THE PROJECT AS INSTRUCTED BY THE INSPECTOR. SUCH ASSISTANCE WILL INCLUDE, BUT NOT BE LIMITED TO OPENING HANDHOLES, MANHOLES AND VARIOUS ACCESS COVERS, DISCONNECTING AND RECONNECTING FUSE HOLDERS AND MECHANICAL SPLICE CONNECTIONS, VERIFYING CONDUIT RUNS, ETC.
- PRIOR TO REQUESTING FINAL STREETLIGHT SERVICE CONNECTION, CONTRACTOR MUST CORRECT ALL PUNCH LIST ITEMS AND CALL FOR A RE-INSPECTION WHERE REQUIRED BY THE INSPECTOR. CONTRACTOR MUST PREPARE A SIGNED AS-BUILT AND WIRING DIAGRAM WHICH INCLUDES WHICH DUCT IS USED IN EACH DUCT BANK.

ROADWAY GENERAL NOTES

- FOR REQUIREMENTS REGARDING THE PROTECTION AND RESTORATION OF PUBLIC AND PRIVATE PROPERTY SEE CITY OF SEATTLE STANDARD SPECIFICATIONS SECTIONS 1-07.16 & 1-07.17.
- THE CONTRACTOR IS RESPONSIBLE FOR REFERENCING AND REPLACING ALL SURVEY MONUMENTS THAT MAY BE DISTURBED, DESTROYED OR REMOVED BY THE PROJECT AND AT LEAST 2 WORKING DAYS PRIOR TO THE WORK, MUST FILE AN APPLICATION FOR PERMIT TO REMOVE OR DESTROY A SURVEY MONUMENT WITH THE WASHINGTON STATE DEPARTMENT OF NATURAL RESOURCES, PURSUANT TO WAC 332-120.
- TREES, SHRUBS AND OTHER PLANT MATERIAL NOT DESIGNATED FOR REMOVAL MUST BE PROTECTED FROM DAMAGE. SEE CITY OF SEATTLE STANDARD SPECIFICATIONS SECTIONS 1-07.16(2) AND 8-01 FOR REQUIREMENTS REGARDING THE TREE, VEGETATION AND SOIL PROTECTION PLAN.
- RESTORATION OF CONTRACTOR DAMAGE TO EXISTING UTILITIES WILL BE AT THE CONTRACTOR'S EXPENSE.
- ALL EXCAVATIONS ADJACENT TO SEATTLE CITY LIGHT POLES OR OTHER FACILITIES (VAULTS, HANDHOLES, ETC.) MUST COMPLY WITH WAC 296-155 PART N, EXCAVATION, TRENCHING AND SHORING. POLE PROTECTION/ SUPPORTING SYSTEMS USED WHILE EXCAVATING MUST COMPLY WITH WAC 296-155-655, GENERAL PROTECTION REQUIREMENTS, ITEM (9) AND MUST NOT AFFECT THE STRUCTURAL INTEGRITY OF POLES WHILE THE SYSTEMS ARE IN PLACE OR AFTER THE SYSTEMS HAVE BEEN REMOVED.
- PAVEMENT, SIDEWALK AND CURB REMOVALS MUST EXTEND TO EXISTING JOINTS, TO LIMITS IDENTIFIED AS "SAWCUT" ON THE DRAWINGS, OR TO LIMITS DETERMINED BY THE ENGINEER. SEE CITY OF SEATTLE STANDARD SPECIFICATIONS SECTION 2-02.3.
- ALL JOINTS AT THE MEET LINES OF NEW CONSTRUCTION AND EXISTING SURFACES MUST BE BUTT JOINTS. SEE CITY OF SEATTLE STANDARD SPECIFICATIONS SECTION 5-04.3(10)B.
- LONGITUDINAL JOINTS MUST BE COORDINATED WITH THE CHANNELIZATION DRAWINGS. LONGITUDINAL JOINTS MUST BE AT A LANE LINE OR EDGE OF TRAVELED WAY UNLESS APPROVED OTHERWISE IN WRITING BY THE ENGINEER. SEE CITY OF SEATTLE STANDARD SPECIFICATIONS SECTION 5-05.3(8)E2.
- PAVING AROUND INLETS AND CATCH BASINS MUST BE SLOPED TO ESTABLISH A DRAINAGE TRANSITION ZONE PER CITY OF SEATTLE STANDARD PLAN 260A.
- THE CONTRACTOR MUST IMMEDIATELY REPORT ANY DAMAGE TO THE TRAFFIC SIGNAL SYSTEM, INCLUDING CONDUIT AND THE DETECTOR LOOPS TO THE KING COUNTY PROJECT REPRESENTATIVE.
- THE CONTRACTOR MUST CONTACT KING COUNTY PROJECT REPRESENTATIVE AND SDOT TRAFFIC SIGNAL OPERATIONS WHEN THE TRAFFIC SIGNAL SYSTEMS OR THE TRAFFIC DETECTOR LOOPS MAY BE IMPACTED BY CONSTRUCTION. ADVANCE NOTIFICATION IS REQUIRED.
- TO ORDER SDOT PROVIDED SIGNS, OR TO COORDINATE SDOT'S INSTALLATION OF SIGNS, SEE SECTION 8-21.3(1) OF CITY OF SEATTLE STANDARD SPECIFICATIONS. ADVANCE NOTIFICATION IS REQUIRED. CONTACT SDOT SIGNS AND MARKING SHOP AT (206)233-7104.
- ALL DRAINAGE INLETS ON AND OFF THE BRIDGE SHALL BE PROTECTED FROM CONSTRUCTION RUNOFF AND DEBRIS.
- ALL CURBS AND SIDEWALK DISTURBED SHALL BE RESTORED. ALL EXISTING ADA RAMPS SHALL BE PROTECTED IN PLACE.
- THE CONTRACTOR IS RESPONSIBLE FOR ALL TRAFFIC CONTROL MEASURES. THE APPROVED TRAFFIC CONTROL PLANS IN THE PROJECT SPECIFICATION APPENDIX ARE FOR CONTRACTOR'S GENERAL REFERENCES ONLY. CONTRACTOR IS RESPONSIBLE FOR OBTAINING APPROVED TRAFFIC CONTROL PLANS THAT SUPPORT THEIR CONSTRUCTION MEANS AND METHODS.
- THE CONTRACTOR SHALL SURVEY ALL EXISTING SIGNS ON THE EXISTING POLES INCLUDING SIGN TYPES AND MOUNTING HEIGHT, AND RESTORE SIGNS AFTER NEW POLE PLACEMENT. SEE SHEET ST6.01 FOR SIGN DETAILS. CONTRACTOR SHALL FIELD VERIFY ALL SIGNS. CONTRACTOR SHALL MAINTAIN AND PROVIDE SUPPORT TO EXISTING MANDATORY TRAFFIC SIGNS DURING CONSTRUCTION.

WARNING! HIGH VOLTAGE OVERHEAD TROLLEY POWER WIRES ARE LOCATED WITHIN AND ADJACENT TO THE WORK ZONE. SEE SPECIFICATIONS FOR REQUIRED SAFETY PROCEDURES.

Z:\210127 KC University Pole Replacement\CADD\SHEET 2-3_G0.02-G0.03 GENERAL NOTES.dwg | Layout: G0.03 | PLOTTED: Dec 03, 2025 09:39:24am | By: Jane Work | XREFS: KCTDC-BORDER-RHC Engineering IMAGES

No.	REVISION	BY	APPD	DATE

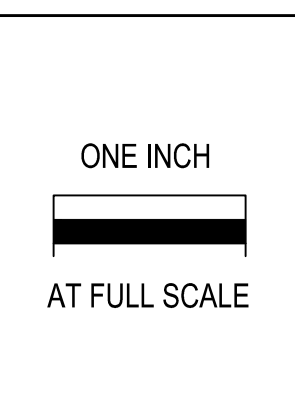

RHC ENGINEERING
 WWW.RHCENGINEERING.COM
 720 3RD AVE SUITE 1400
 SEATTLE WA 98104
 PH: 206.623.5984



DESIGNED: J. LI	APPROVED: G. FRANCO
DRAWN: T. LOZADA	PROJECT NO: 1127254
CHECKED: G. CHEN	CONTRACT NO: -
CHECKED: ---	



METRO TRANSIT CAPITAL DIVISION
TROLLEY OVERHEAD SYSTEM
 UNIVERSITY BRIDGE TROLLEY POLE REPLACEMENT

GENERAL NOTES - 2

DRAWING NO:
G0.03

SHEET NO. OF
3 OF 43

DATE: DECEMBER 2, 2025
DRAWING NO: G0.03
SHEET NO. OF 3 OF 43

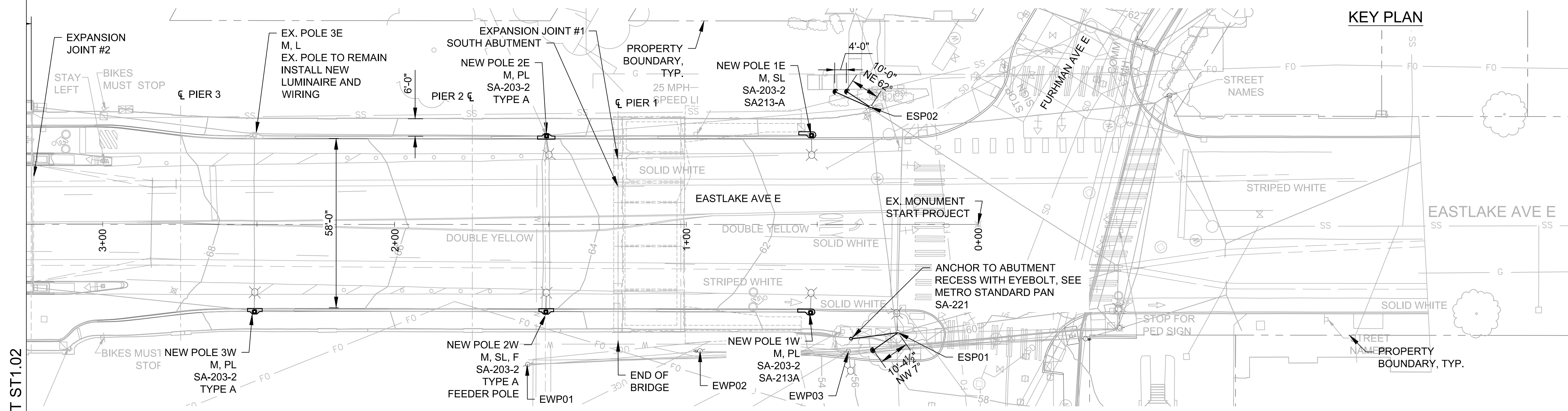
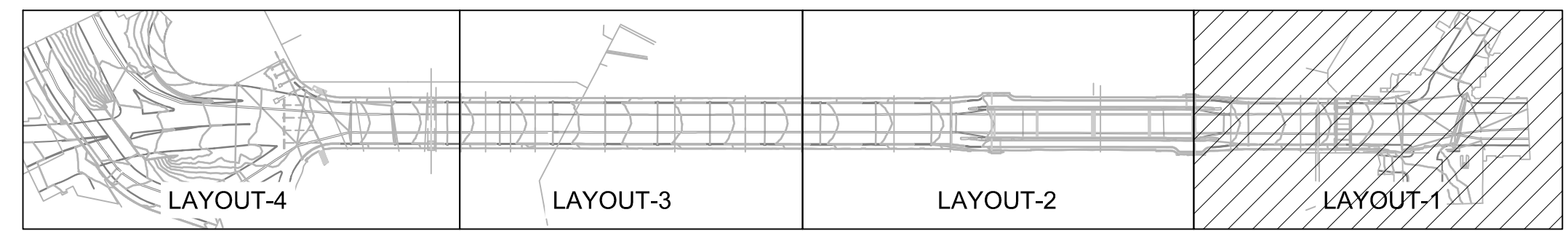
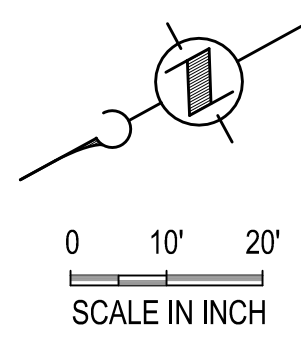

PLAN

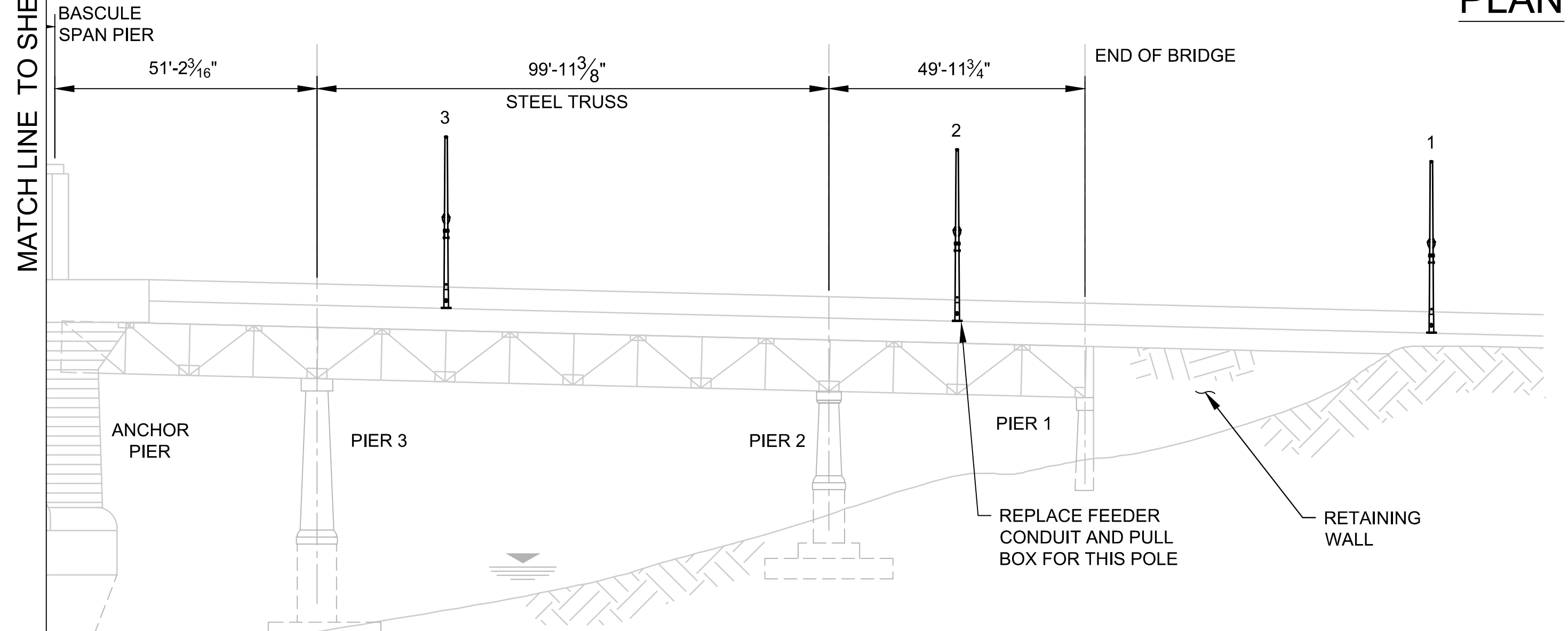

ELEVATION

NOTES:

- SEE SHEETS 2 AND 3 FOR GENERAL NOTES.
- POLES NUMBER 1 TO NUMBER 16 WILL BE REPLACED IN-PLACE AT BOTH SIDES OF THE BRIDGE, EXCEPT POLES 3E AND 12E. THE TOTAL NUMBER OF REPLACEMENT POLES IS 30. POLES 1E, 1W AND 16W ARE ON THE GROUND, ALL OTHER REPLACEMENT POLES ARE ON THE BRIDGE STRUCTURE.
- POLES S1 AND S2 ARE NEW AND MOUNTED ON THE EXISTING SUPERBENT BETWEEN PIERS 14 AND 15.
- SEE SHEET ST6.01 FOR POLE SCHEDULE.
- EXISTING STEEL POLES ESP01 AND ESP02 TO BE GUYED BY TEMPORARY SIDEWAY GUY, OR DOWN GUY ANCHORS, OR ABUTMENT EYEBOLTS. LOCATIONS SHOWN IN THE PLAN ARE APPROXIMATE. CONTRACTOR MUST FIELD VERIFY TO AVOID UTILITY CONFLICTS AND ADJUST WITHIN 2 FEET RADIUS OF PROPOSED LOCATION. NOTIFY KING COUNTY PROJECT REPRESENTATIVE IF UTILITY CONFLICTS OCCUR. CONTRACTOR SHALL BE RESPONSIBLE FOR ANY DAMAGE TO UTILITY FROM ANCHOR CONSTRUCTION.

LEGEND

- 2W, M, L SA-203-2 TYPE A: REPLACEMENT POLE NUMBER
- M, L: METRO OCS AND CITY OF SEATTLE LIGHTING JOINT USE POLE
- SA-203-2: POLE TYPE
- TYPE A: FOUNDATION TYPE
- POLE BASE CONSTRUCTION AREA

2/3/2027 KCM University Pole Replacement/CADD SHEET 47 ST1.01 ST1.04 PLAN AND ELEVATION.dwg | Layout: ST1.01
 PLOTTED: Dec 08, 2025 10:38:46 AM By: Lisa Wok
 XREFS: KCM University Bridge Trolley_2D Basemap; KCM University Bridge Trolley_Topog; KCTDC-BORDER-RHC Engineering IMAGES;

No.	REVISION	BY	APP'D	DATE

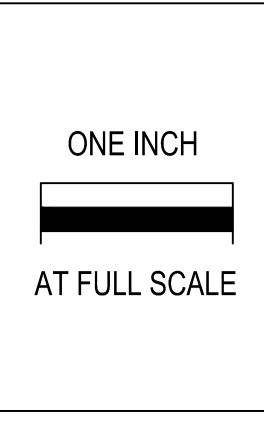

RHC ENGINEERING
 WWW.RHCENGINEERING.COM
 720 3RD AVE SUITE 1400
 SEATTLE WA 98104
 PH: 206.623.5984

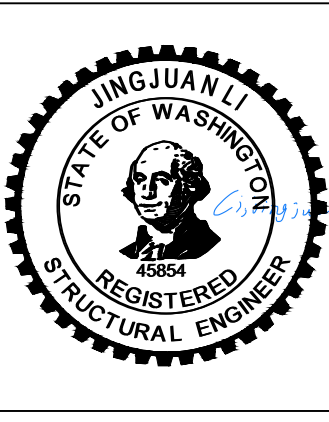

DESIGNED: J. LI	APPROVED: G. FRANCO
DRAWN: T. LOZADA	PROJECT NO: 1127254
CHECKED: G. CHEN	CONTRACT NO: -



METRO TRANSIT CAPITAL DIVISION
TROLLEY OVERHEAD SYSTEM
UNIVERSITY BRIDGE TROLLEY POLE REPLACEMENT

PLAN AND ELEVATION - 1

DATE: DECEMBER 2, 2025
DRAWING NO: ST1.01
SHEET NO. OF 4 43

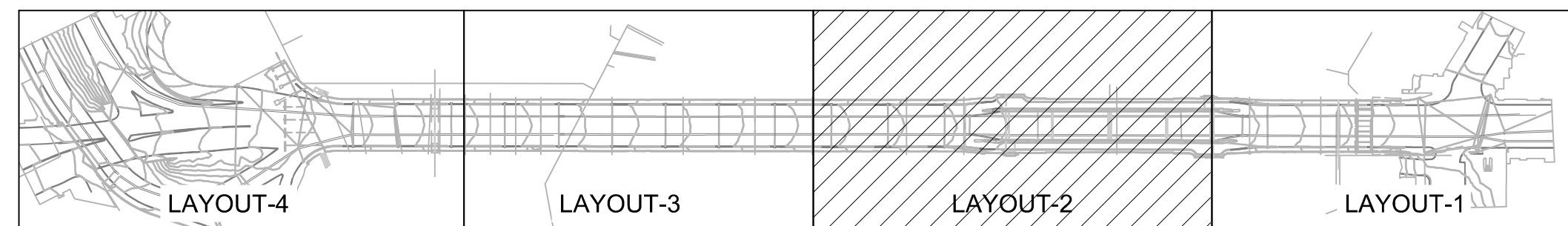
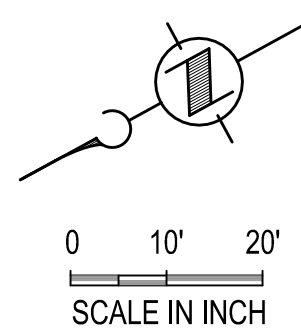

KEY PLAN

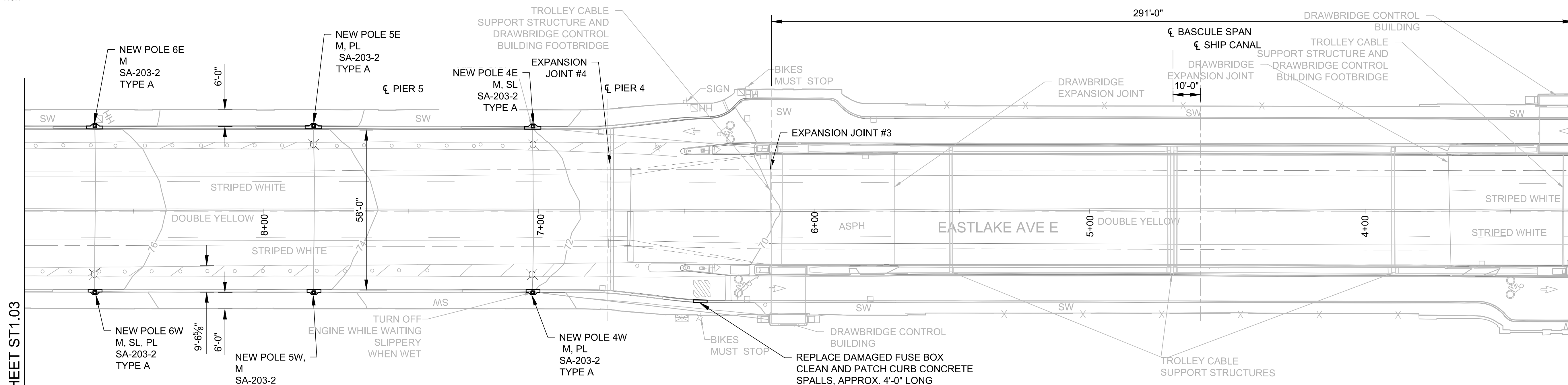

PLAN

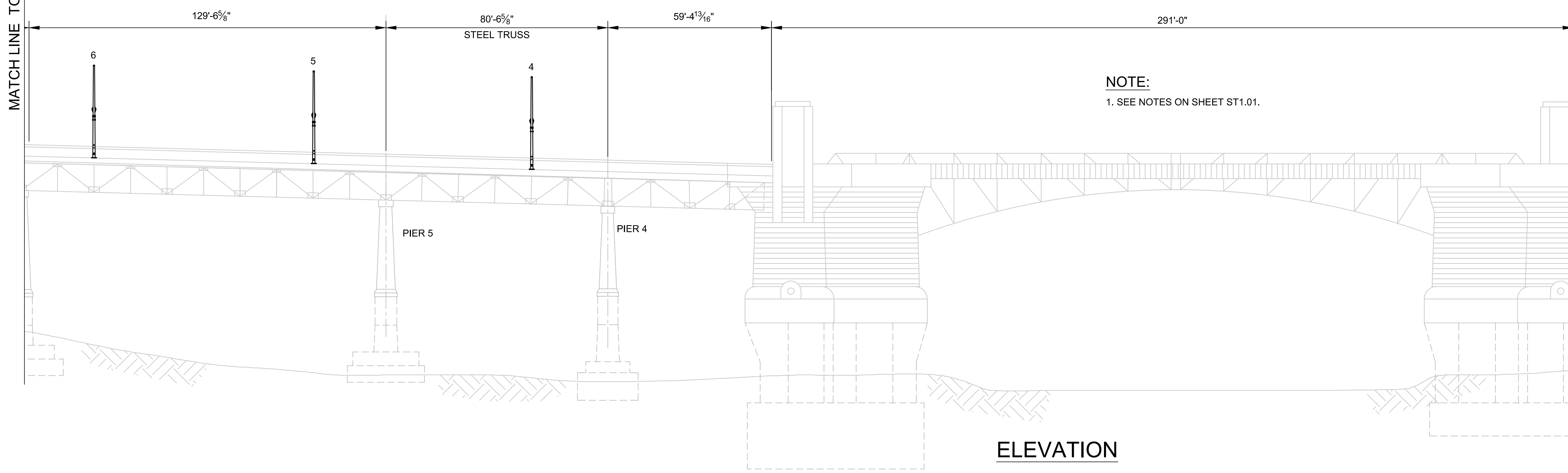

ELEVATION

NOTE:
1. SEE NOTES ON SHEET ST1.01.

7/23/2021 KCM University Bridge Replacement/CADD/SHEET 47 ST1.01-ST1.04 PLAN AND ELEVATION.dwg | Layout: ST1.02
 PLOTTED: Dec 02, 2025 09:55:52pm By Jane Work
 XREFS: KCM University Bridge Trolley_2D BaseMap; KCM University Bridge Trolley_Top; KCTDC-BORDER-RHC Engineering IMAGES;

No.	REVISION	BY	APPD	DATE

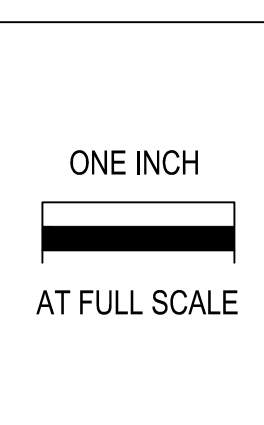

RHC ENGINEERING
 WWW.RHCENGINEERING.COM
 720 3RD AVE SUITE 1400
 SEATTLE WA 98104
 PH: 206.623.5984

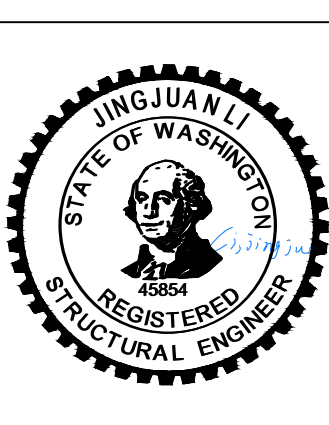

DESIGNED: J. LI	APPROVED: G. FRANCO
DRAWN: T. LOZADA	PROJECT NO: 1127254
CHECKED: G. CHEN	CONTRACT NO:
CHECKED: 	



METRO TRANSIT CAPITAL DIVISION
 TROLLEY OVERHEAD SYSTEM
 UNIVERSITY BRIDGE TROLLEY POLE REPLACEMENT

PLAN AND ELEVATION - 2

DATE: DECEMBER 2, 2025
DRAWING NO: ST1.02
SHEET NO. OF 5 OF 43

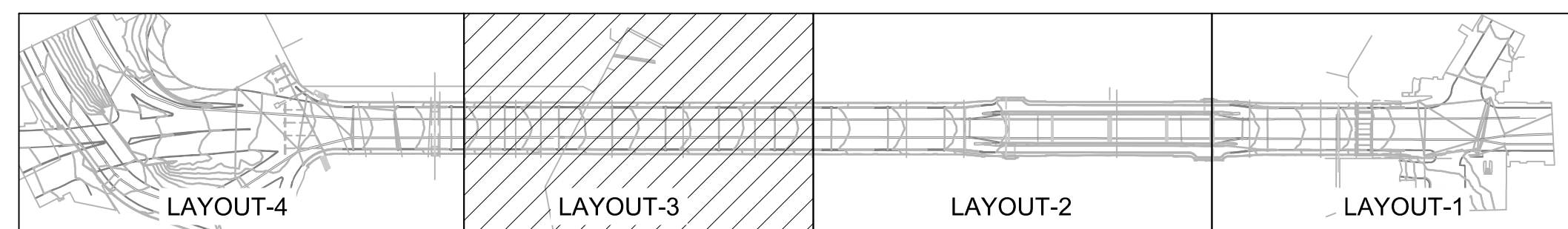
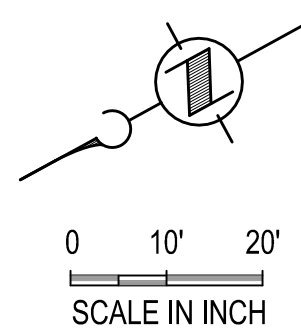

KEY PLAN

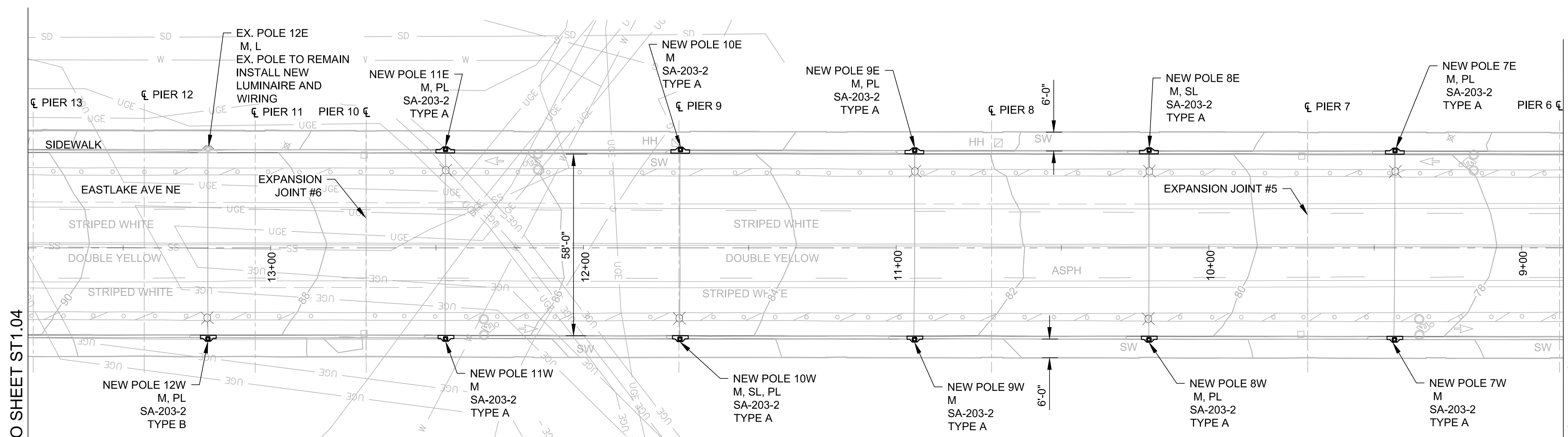

PLAN

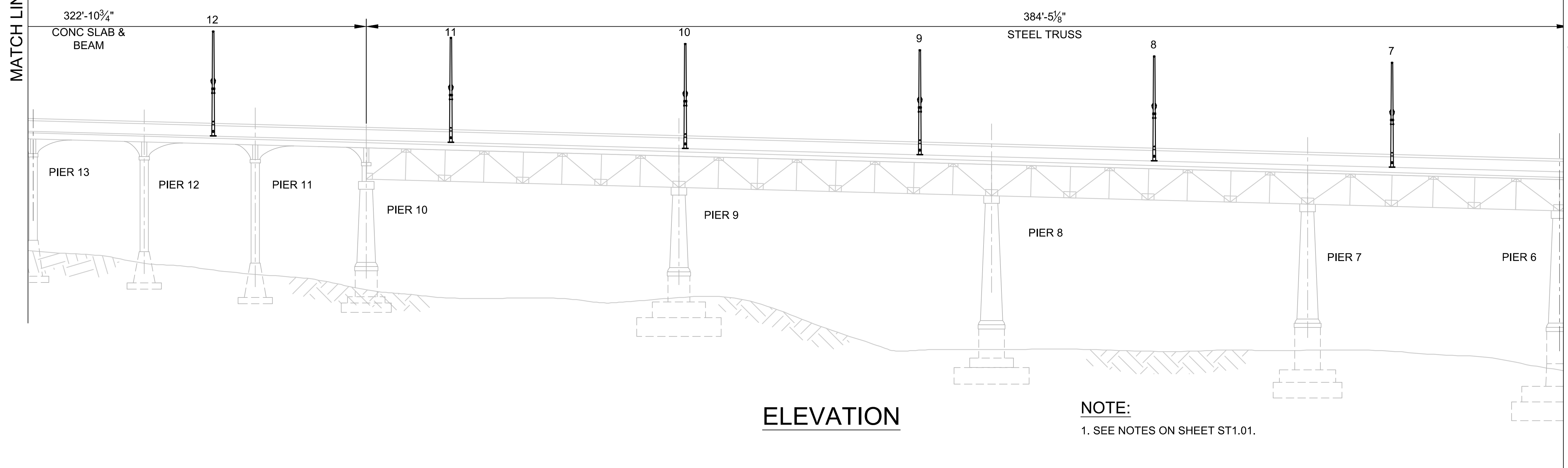

ELEVATION

NOTE:
1. SEE NOTES ON SHEET ST1.01.

7/20/2021 KCM University Pole Replacement/CADD SHEET 4.7 ST1.01-ST1.04 PLAN AND ELEVATION.dwg | Layout: ST1.03
 PLOTTED: Dec 02, 2025 09:58:27 pm By: Work
 XREFS: KCM University Bridge Trolley_2D BaseMap; KCM University Bridge Trolley_Top; KCTDC-BORDER-RHC Engineering
 IMAGES:

No.	REVISION	BY	APPD	DATE

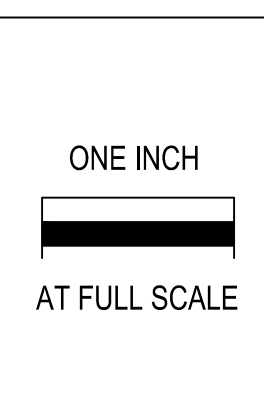

RHC ENGINEERING
 WWW.RHCENGINEERING.COM
 720 3RD AVE SUITE 1400
 SEATTLE WA 98104
 PH: 206.623.5984

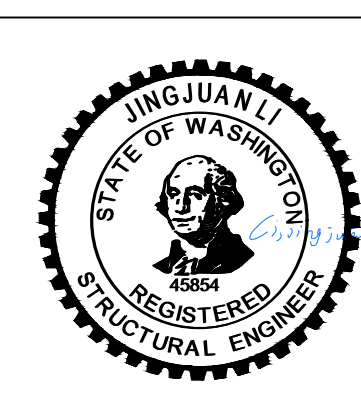

DESIGNED: J. LI	APPROVED: G. FRANCO
DRAWN: T. LOZADA	PROJECT NO.:
CHECKED: G. CHEN	1127254
CHECKED:	CONTRACT NO.:



METRO TRANSIT CAPITAL DIVISION
 TROLLEY OVERHEAD SYSTEM
 UNIVERSITY BRIDGE TROLLEY POLE REPLACEMENT

PLAN AND ELEVATION - 3

DATE: DECEMBER 2, 2025
DRAWING NO.:
ST1.03
SHEET NO. OF
6 43

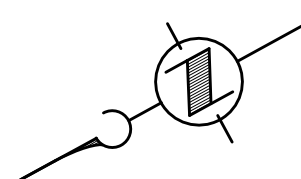

0 10' 20'
SCALE IN INCH

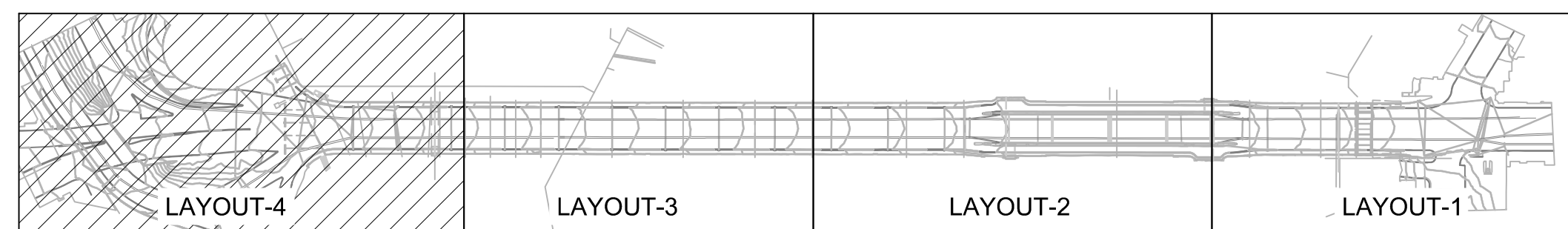

KEY PLAN

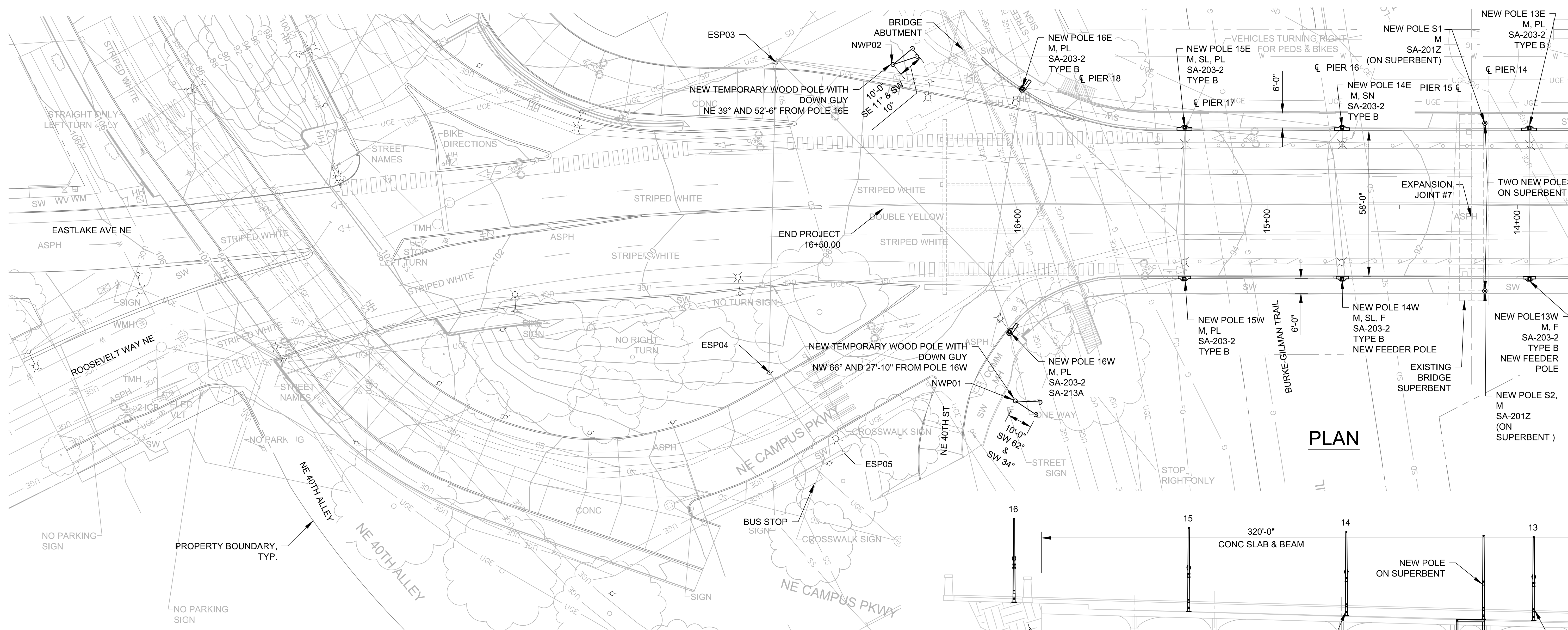

PLAN

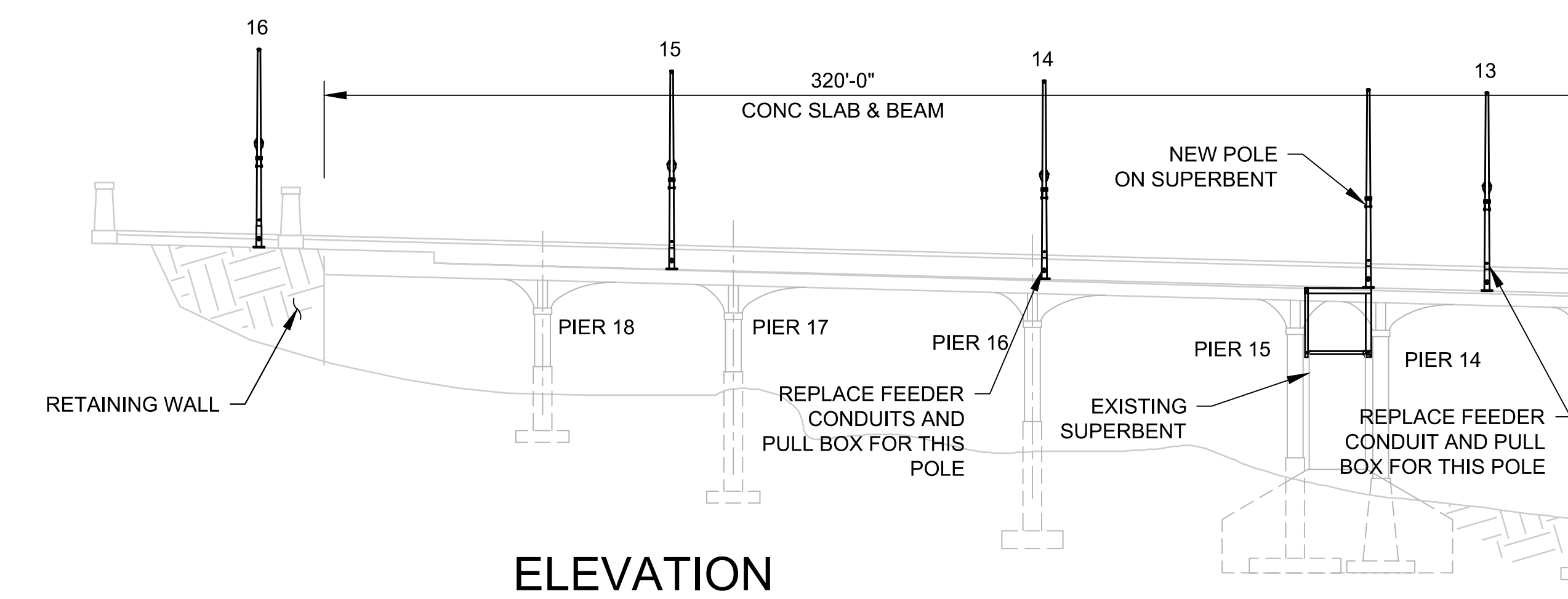

ELEVATION

NOTES:

- SEE NOTES ON SHEET ST1.01.
- LOCATIONS FOR TEMPORARY WOOD POLES NWP01 AND NWP02 AND DOWN GUY ANCHORS SHOWN IN THE PLAN ARE APPROXIMATE. CONTRACTOR MUST FIELD VERIFY TO AVOID UTILITY CONFLICTS AND ADJUST WITHIN 2 FEET RADIUS OF PROPOSED LOCATION. NOTIFY KING COUNTY PROJECT REPRESENTATIVE IF UTILITY CONFLICTS OCCUR. CONTRACTOR SHALL BE RESPONSIBLE FOR ANY DAMAGE TO UTILITY FROM POLE AND ANCHOR CONSTRUCTION.

MATCH LINE TO SHEET ST1.03

Z:\2022\12\17\KC University Pole Replacement\CADD\SHEET 4-7 ST1.01-ST1.04 PLAN AND ELEVATION.dwg | Layout: ST1.04
PLOTTED: Dec 19, 2025 05:11:03pm By: Jane Wolk
XREFS: KCM University Bridge Trolley_2D BaseMap; KCM University Bridge Trolley_Top; KCTDC-BORDER-RHC Engineering IMAGES.

No.	REVISION	BY	APPD	DATE

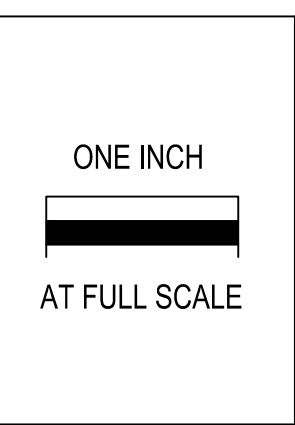

RHC ENGINEERING
WWW.RHCENGINEERING.COM
 720 3RD AVE SUITE 1400
 SEATTLE WA 98104
 PH: 206.623.5984

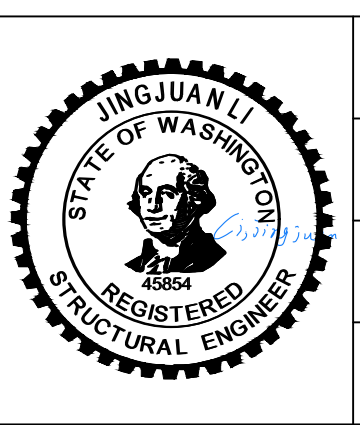

DESIGNED: J. LI	APPROVED: G. FRANCO
DRAWN: T. LOZADA	PROJECT NO: 1127254
CHECKED: G. CHEN	CONTRACT NO: -



METRO TRANSIT CAPITAL DIVISION
 TROLLEY OVERHEAD SYSTEM
 UNIVERSITY BRIDGE TROLLEY POLE REPLACEMENT

PLAN AND ELEVATION - 4

DATE: DECEMBER 2, 2025
DRAWING NO: ST1.04
SHEET NO. OF 7 43

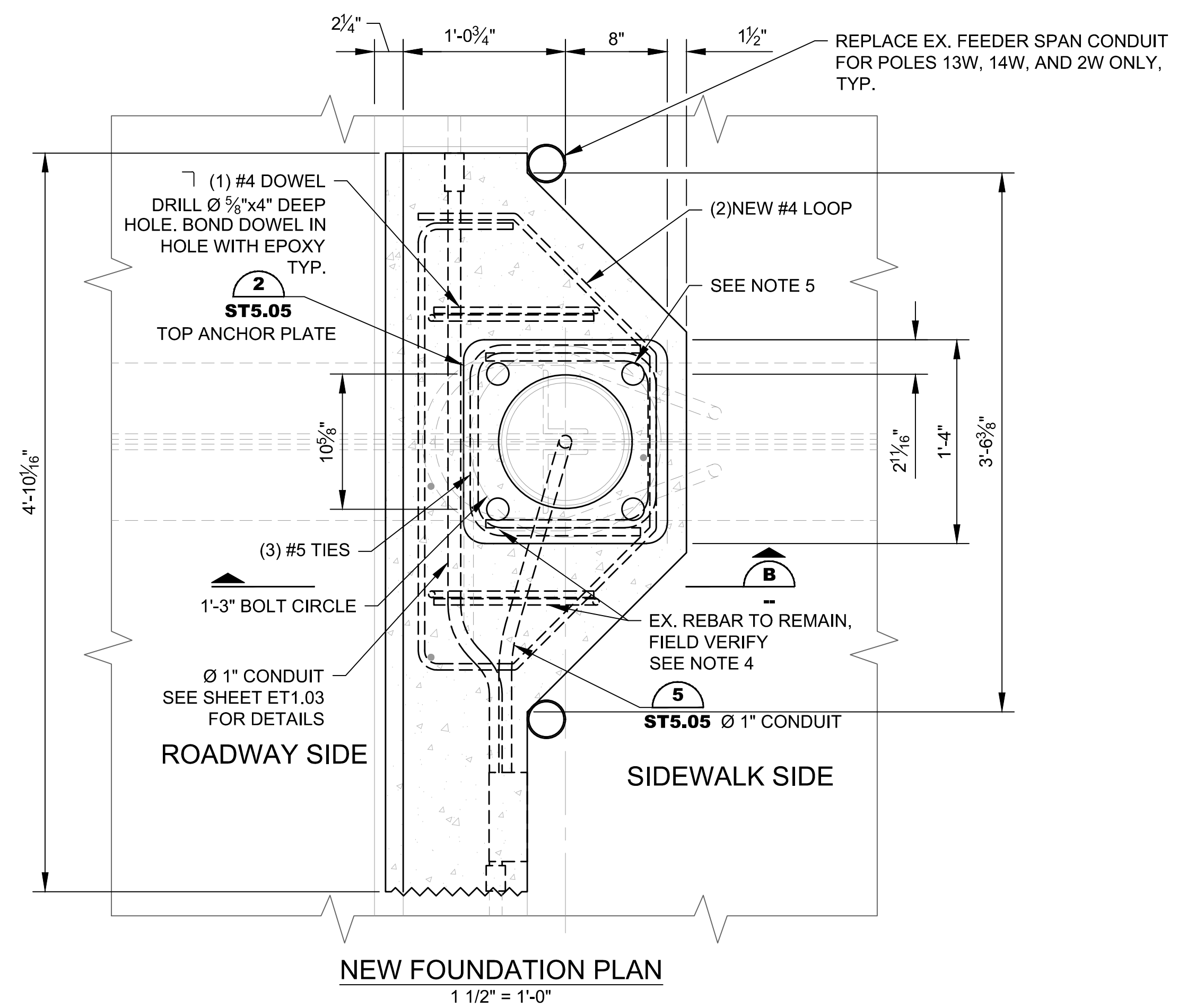
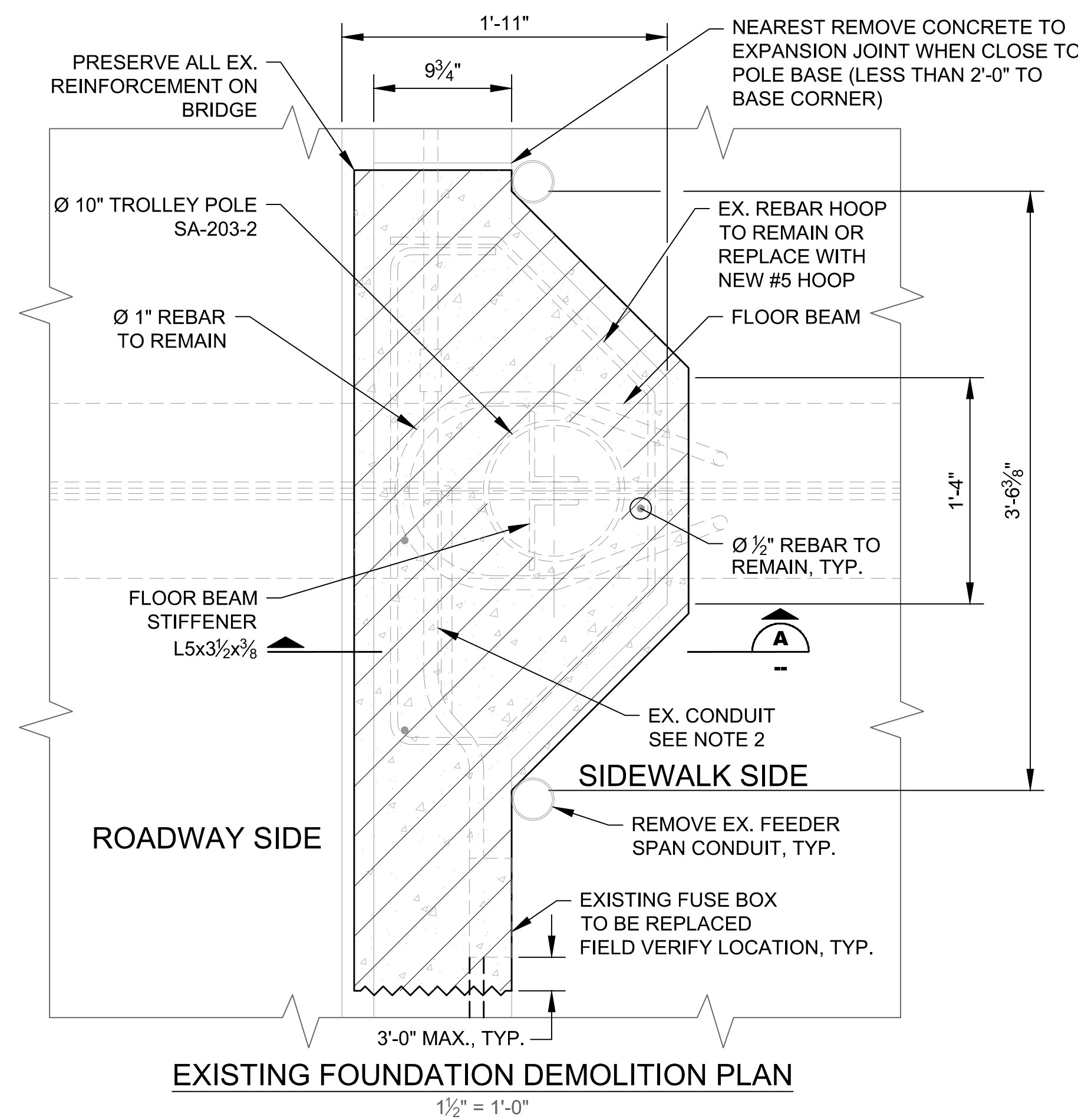

- NOTES:**
- FIELD VERIFY ALL CONDITIONS AND DIMENSIONS PRIOR TO CONSTRUCTION. NOTIFY ENGINEER IF DISCREPANCIES OR CONFLICTS ARE FOUND. CONTRACTOR MUST VERIFY ALL EXISTING BRIDGE REINFORCEMENT AND MUST NOT CUT OR DAMAGE EXISTING REINFORCEMENT DURING CONCRETE REMOVAL AND DRILLING.
 - CUT EXISTING POLE STUB AND $\frac{3}{4}$ " CONDUIT TO TOP OF THE TRAFFIC CURB.
 - LOCATE EX. REBAR AND CONDUITS PRIOR TO CONSTRUCTION. REPLACE EXISTING TROLLEY POWER CONDUIT.
 - CHIP OUT EX. CONCRETE AS SHOWN TO REMOVE THE REMAINDER OF EX. $\frac{3}{4}$ " CONDUIT AND INSTALL THE NEW $\frac{1}{2}$ " CONDUIT. CAUTION SHALL BE EXERCISED TO AVOID EXISTING CONDUITS AND REBARS FROM BEING DAMAGED DURING CHIPPING OPERATION. CUT ADDITIONAL EX. POLE STUB AS NECESSARY TO INSTALL THE NEW CONDUIT AND FILL THE REMAINING POLE HOLE WITH NON-SHRINK GROUT. THE WHOLE PROCESS OF CONCRETE CHIPPING AND CONDUIT INSTALLATION PROCESS SHALL BE OBSERVED BY A KING COUNTY PROJECT REPRESENTATIVE AND A LICENSED STRUCTURAL ENGINEER. AFTER THE NEW CONDUIT IS INSTALLED, CLEAN THE EXISTING REBARS AND COAT WITH ANTI-CORROSION COATING. PLACE POLYMER MODIFIED CONCRETE TO RESTORE ORIGINAL TRAFFIC CURB SHAPE.
 - DRILL $\frac{1}{4}$ " HOLES THROUGH THE CURB AND FLOOR BEAM TOP FLANGE (4 REQ'D), CAUTION SHALL BE EXERCISED TO AVOID EXISTING CONDUITS AND REBARS FROM BEING DAMAGED DURING DRILLING OPERATION. CONTRACTOR SHALL NOT FLAME CUT HOLE THROUGH THE TOP STEEL FLANGE. SPRAY ALL EXPOSED STEEL PARTS WITH A ZINC-RICH PRIMER AND PAINT TO MATCH EX. COLOR OF THE BRIDGE. NOTIFY KING COUNTY PROJECT REPRESENTATIVE MINIMUM FIVE DAYS PRIOR TO DRILLING.
 - INSTALL STEEL PLATES AND ANCHOR BOLTS WITH NUTS AND WASHERS. FILL THE VOIDS WITH NON-SHRINK GROUT.
 - SLOT FOR STEEL ANCHOR PLATE SHALL NOT BE FLAME CUT; ANY CUT SURFACES SHALL BE PREPPED, PRIMED AND REPAINTED PER SECTION 6-07 OF THE CITY OF SEATTLE STANDARD SPECIFICATIONS.

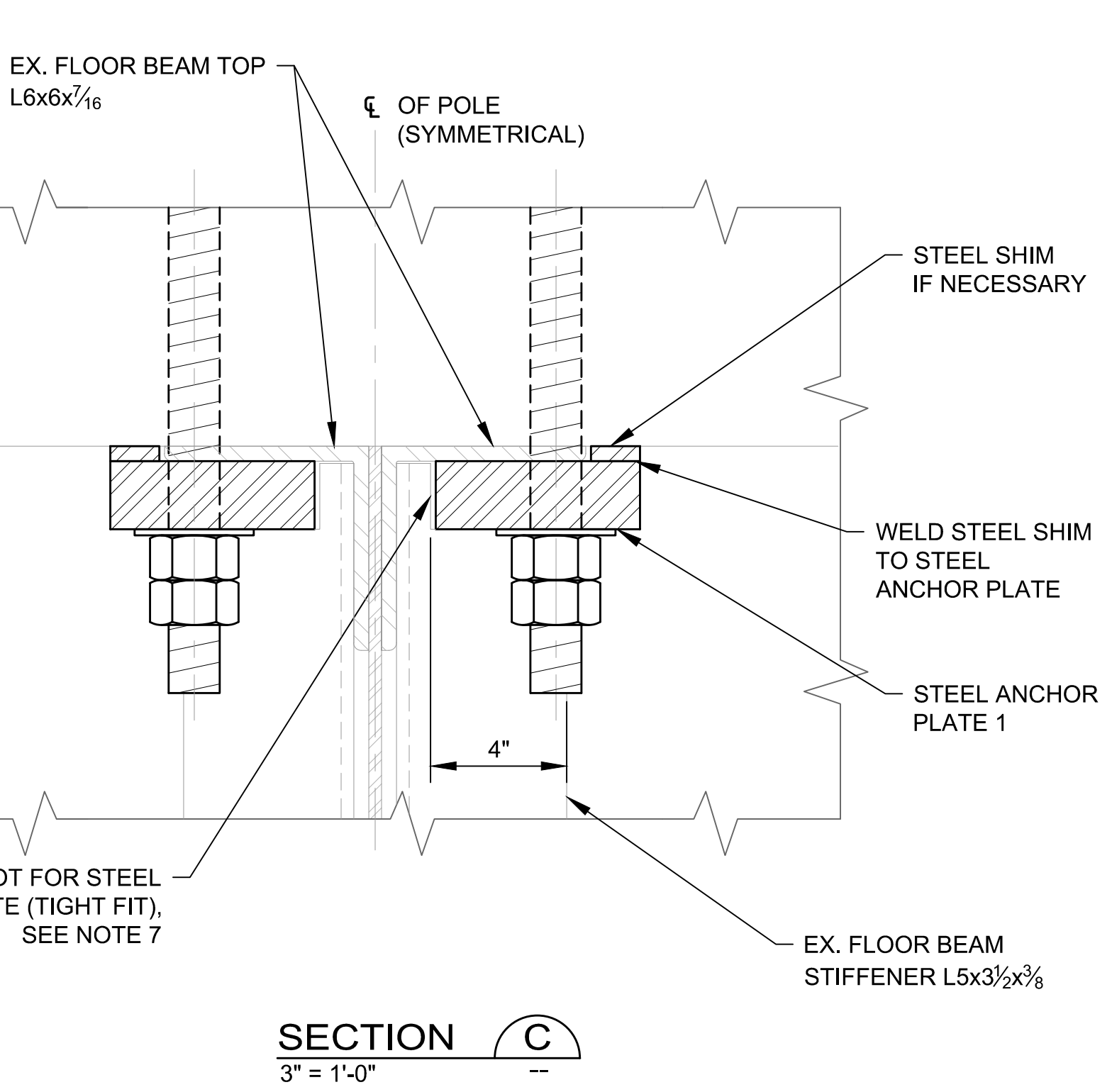
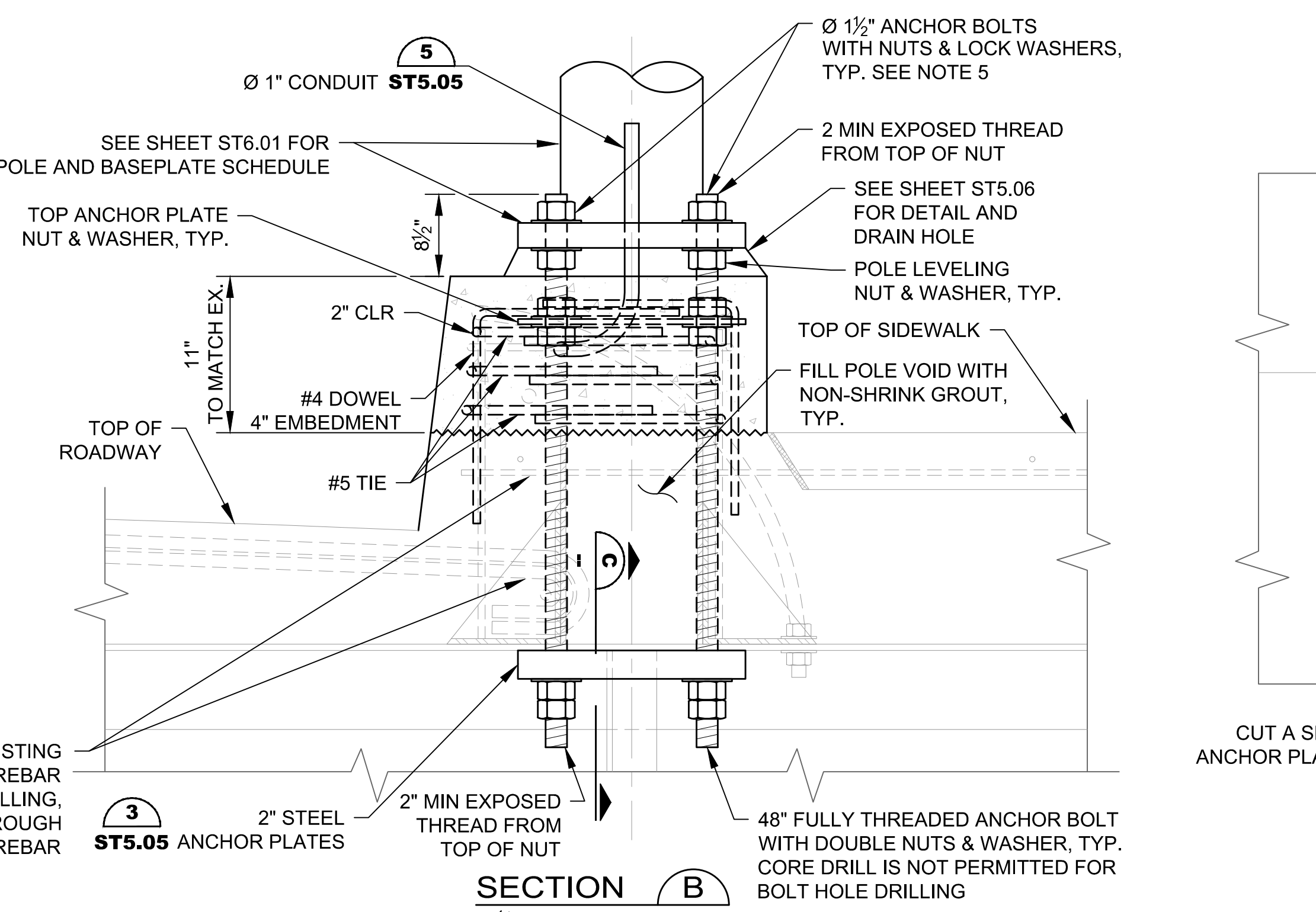
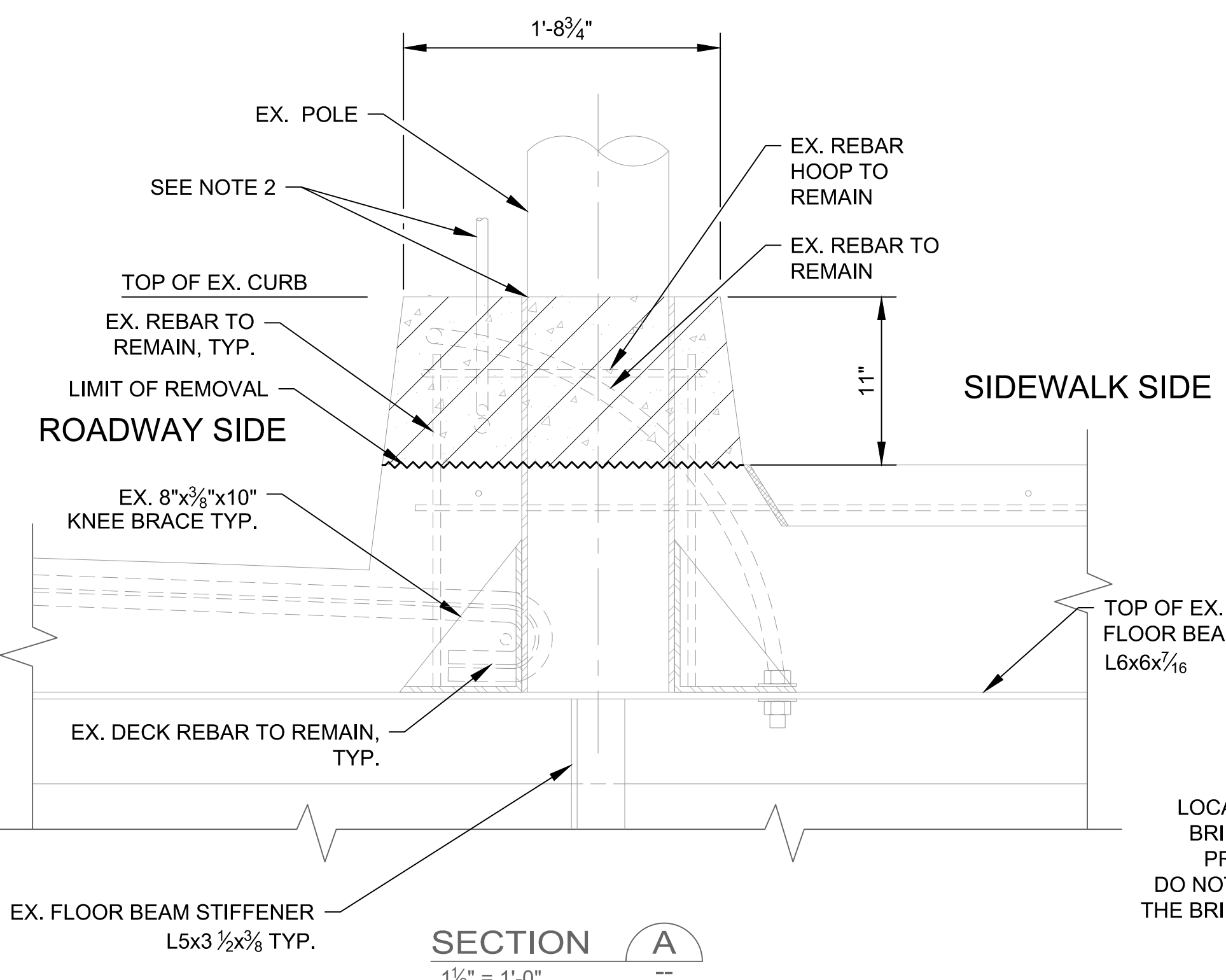
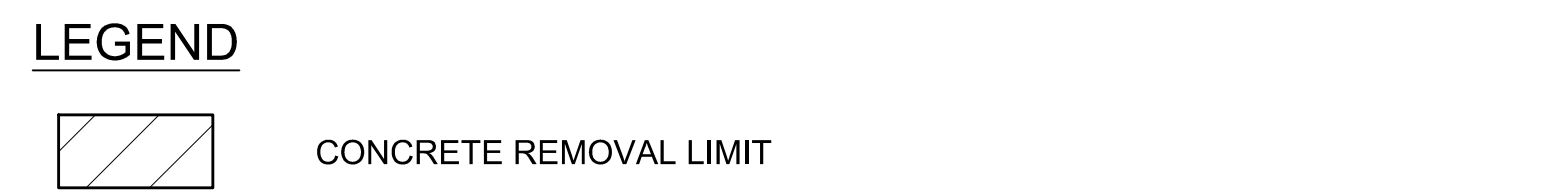

Z:\210127\KC University Pole Replacement\CADD\SHEET 10 ST5.01 POLE FOUNDATION RETROFIT DETAILS ON STEEL BRIDGE.dwg | Layout: ST5.01
 PLOTTED: Dec 11, 2025 09:13:49am By: Jane Work
 XREFS: KC DDC-BORDER-RHC Engineering

No.	REVISION	BY	APP'D	DATE

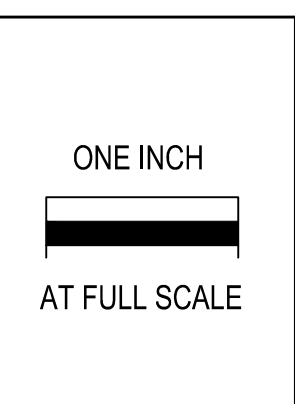

RHC ENGINEERING
 WWW.RHCENGINEERING.COM
 720 3RD AVE SUITE 1400
 SEATTLE WA 98104
 PH: 206.623.5984

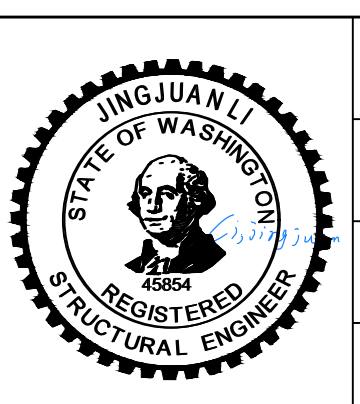

DESIGNED: J. LI	APPROVED: G. FRANCO
DRAWN: T. LOZADA	PROJECT NO: 1127254
CHECKED: G. CHEN	CONTRACT NO:



METRO TRANSIT CAPITAL DIVISION
 TROLLEY OVERHEAD SYSTEM
 UNIVERSITY BRIDGE TROLLEY POLE REPLACEMENT
**POLE FOUNDATION DETAILS
 ON STEEL BRIDGE SPANS
 (TYPE A)**

DATE: DECEMBER 2, 2025
DRAWING NO: ST5.01
SHEET NO. OF 10 43

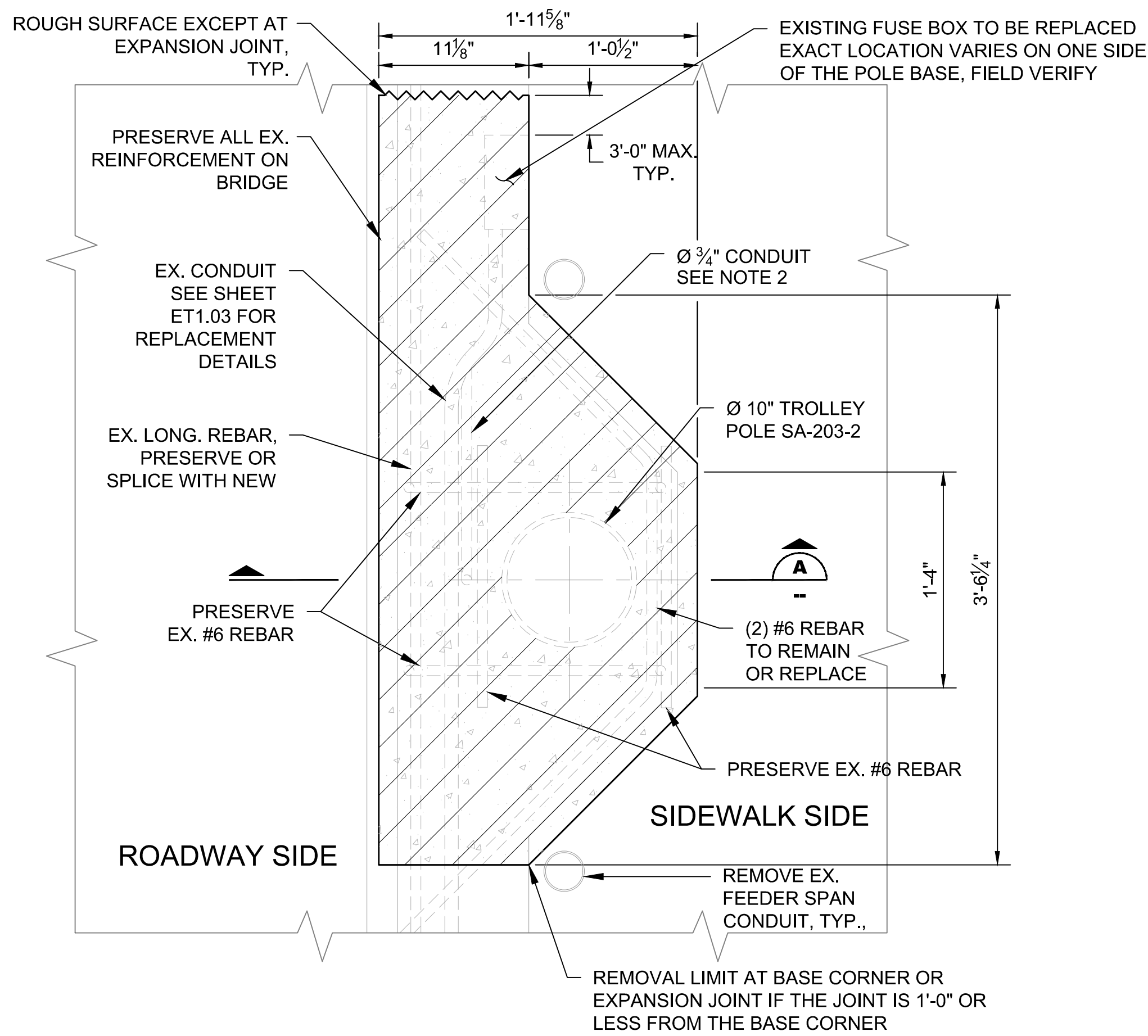

EXISTING FOUNDATION DEMOLITION PLAN

1/2" = 1'-0"

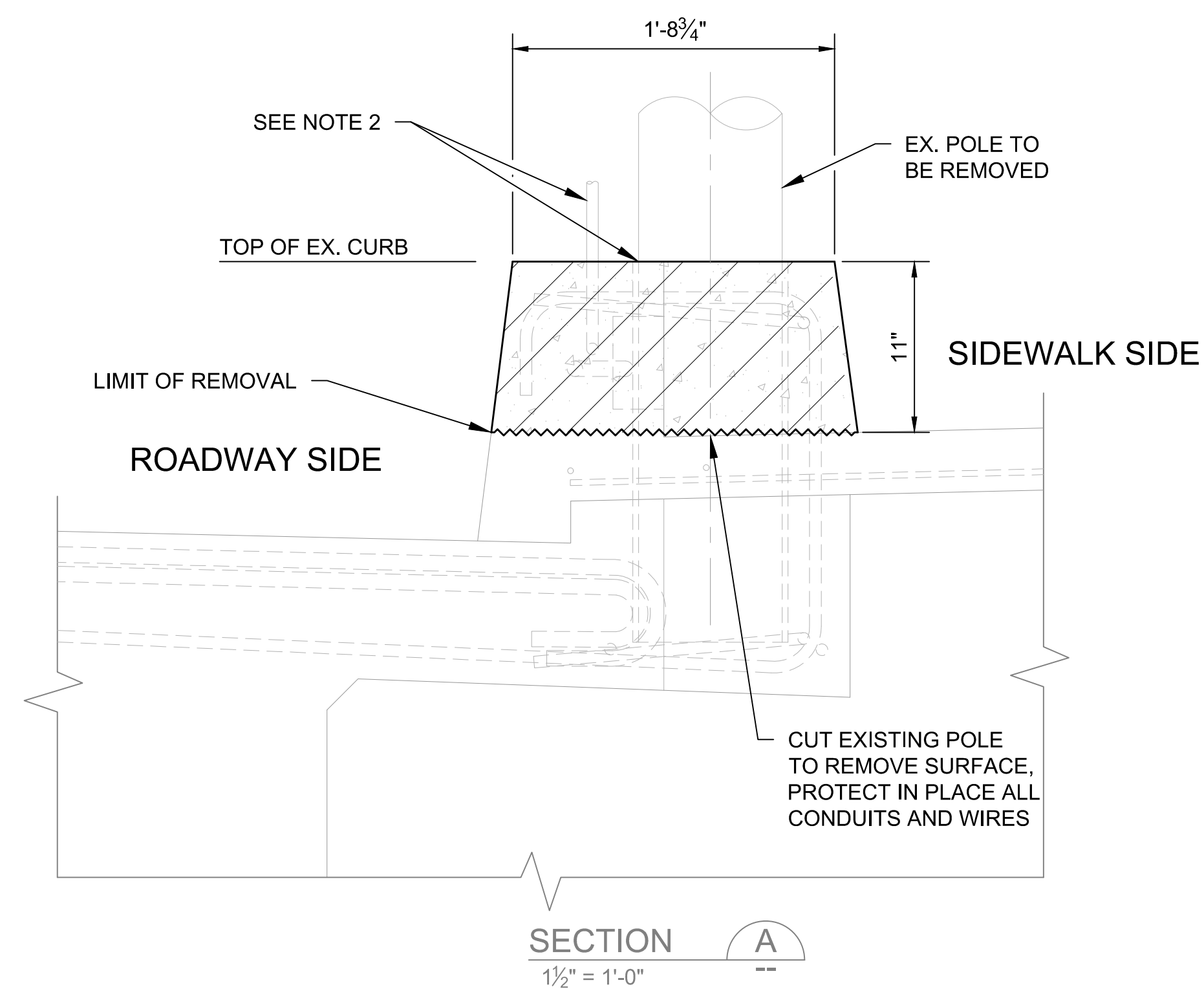

SECTION A

1/2" = 1'-0"

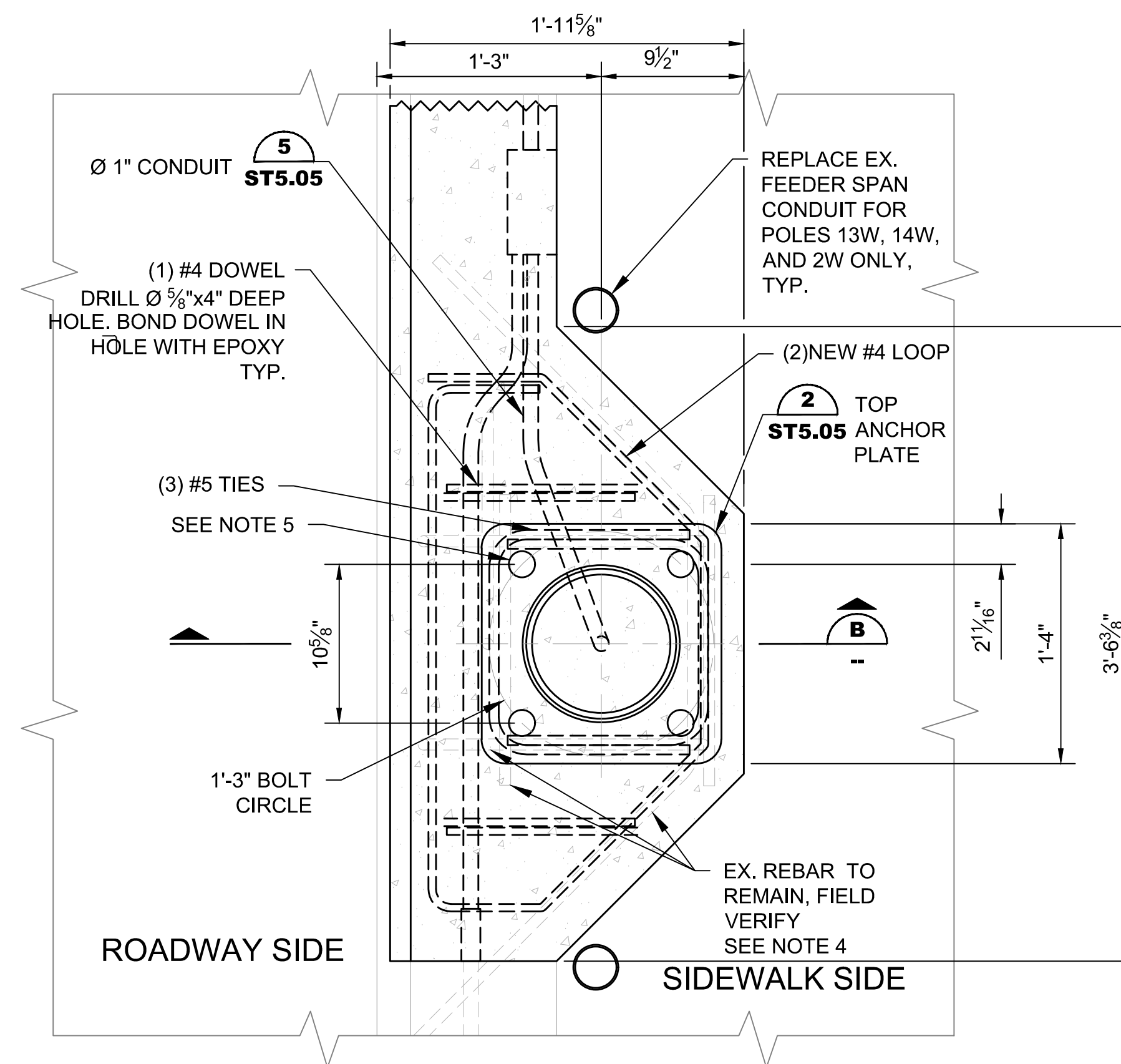

NEW FOUNDATION PLAN

1/2" = 1'-0"

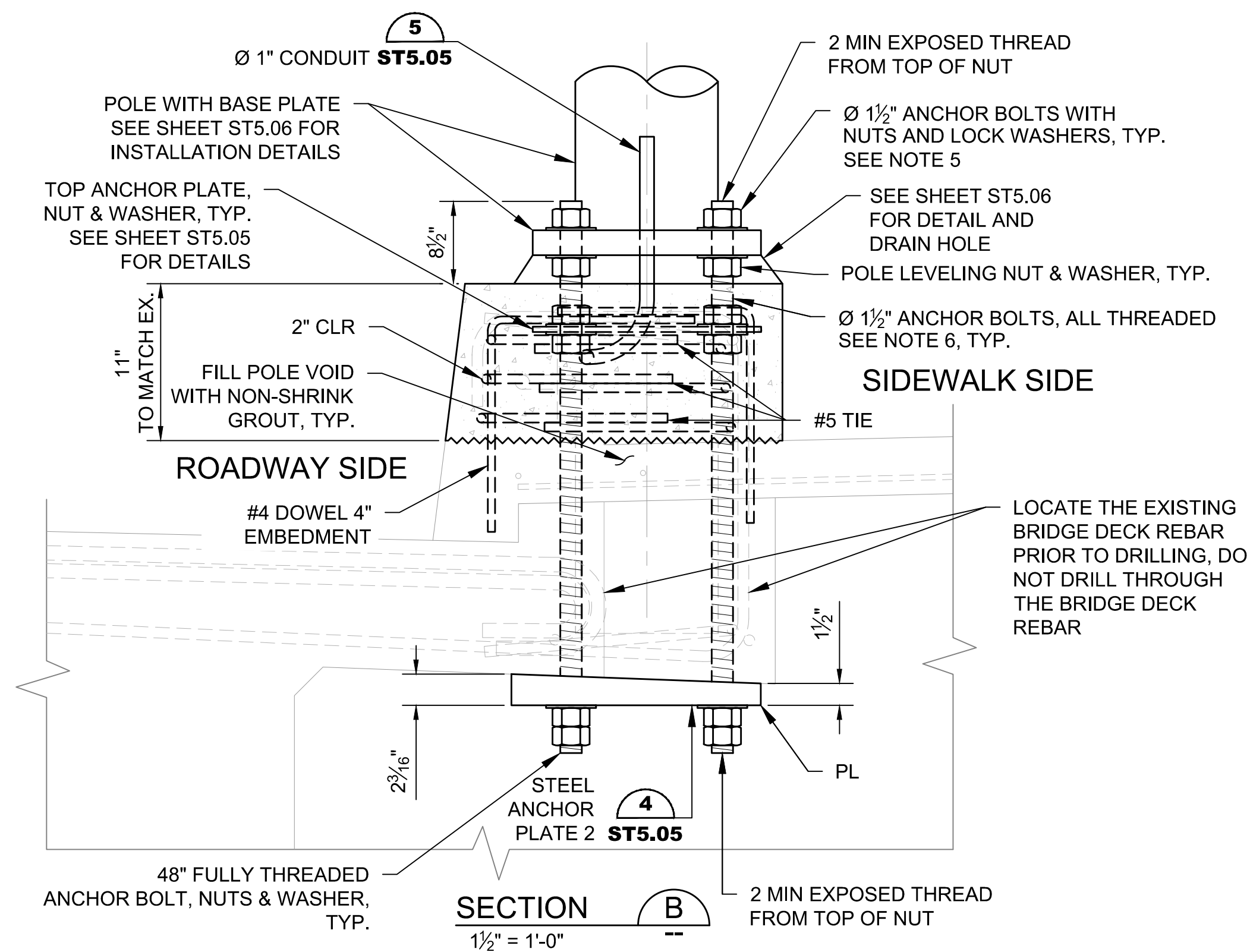

SECTION B

1/2" = 1'-0"

NOTES:

1. FIELD VERIFY ALL CONDITIONS AND DIMENSIONS PRIOR TO CONSTRUCTION. NOTIFY ENGINEER IF DISCREPANCIES OR CONFLICTS ARE FOUND. CONTRACTOR MUST VERIFY ALL EXISTING BRIDGE REINFORCEMENT AND MUST NOT CUT OR DAMAGE EXISTING REINFORCEMENT DURING CONCRETE REMOVAL AND DRILLING.
2. CUT EXISTING POLE & CONDUIT TO TOP OF THE TRAFFIC CURB.
3. LOCATE EXISTING REBAR AND CONDUIT PRIOR TO CONSTRUCTION. REPLACE EXISTING TROLLEY POWER CONDUITS.
4. CHIP OUT EX. CONCRETE AS SHOWN TO REMOVE THE REMAINDER OF EX. CONDUIT AND INSTALL NEW Ø 1" CONDUIT. CAUTION SHALL BE EXERCISED TO AVOID EXISTING REBAR FROM BEING DAMAGED DURING CHIPPING OPERATION. CUT ADDITIONAL EX. POLE AS NECESSARY TO INSTALL THE NEW CONDUIT AND FILL THE REMAINING POLE HOLE WITH NON-SHRINK GROUT. THE WHOLE PROCESS OF CONCRETE CHIPPING AND CONDUIT INSTALLATION PROCESS SHALL BE OBSERVED BY THE KING COUNTY PROJECT REPRESENTATIVE AND A LICENSED STRUCTURAL ENGINEER. AFTER THE NEW CONDUIT IS INSTALLED, CLEAN THE EXISTING REBAR AND COAT WITH ANTI-CORROSION COATING. PLACE POLYMER MODIFIED CONCRETE TO RESTORE ORIGINAL TRAFFIC CURB SHAPE.
5. DRILL Ø 1 3/4" HOLES THROUGH THE CURB (4 REQ'D), CAUTION SHALL BE EXERCISED TO AVOID EXISTING CONDUITS AND REBARS FROM BEING DAMAGED DURING DRILLING OPERATION.
6. INSTALL STEEL PLATES AND ANCHOR BOLTS WITH NUTS AND WASHERS. FILL THE VOIDS WITH NON-SHRINK GROUT.

LEGEND



CONCRETE REMOVAL LIMIT

Z:\210127\KC University Pole Replacement\CADD\SHEET 11 ST5.02 POLE FOUNDATION RETROFIT DETAILS ON CONCRETE BRIDGE.dwg | Layout: ST5.02 | PLOTTED: Dec 05, 2025 09:25:33 pm | By: Jane Work | XREFS: KCDC-BORDER-RHC Engineering IMAGES.

No.	REVISION	BY	APP'D	DATE

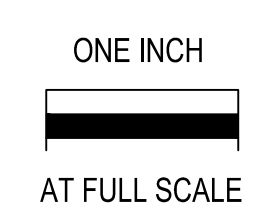

RHC ENGINEERING
 WWW.RHCENGINEERING.COM
 720 3RD AVE SUITE 1400
 SEATTLE WA 98104
 PH: 206.623.5984

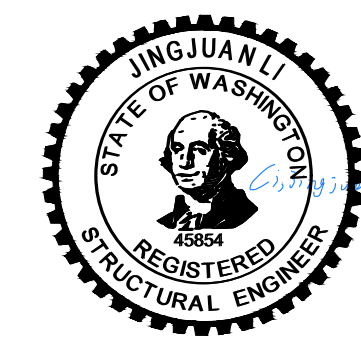

DESIGNED: J. LI	APPROVED: G. FRANCO
DRAWN: T. LOZADA	PROJECT NO: 1127254
CHECKED: G. CHEN	CONTRACT NO:



METRO TRANSIT CAPITAL DIVISION
 TROLLEY OVERHEAD SYSTEM
 UNIVERSITY BRIDGE TROLLEY POLE REPLACEMENT
**POLE FOUNDATION DETAILS
 ON CONCRETE BRIDGE SPANS
 (TYPE B)**

DATE: DECEMBER 2, 2025
DRAWING NO: ST5.02
SHEET NO. OF 11 43

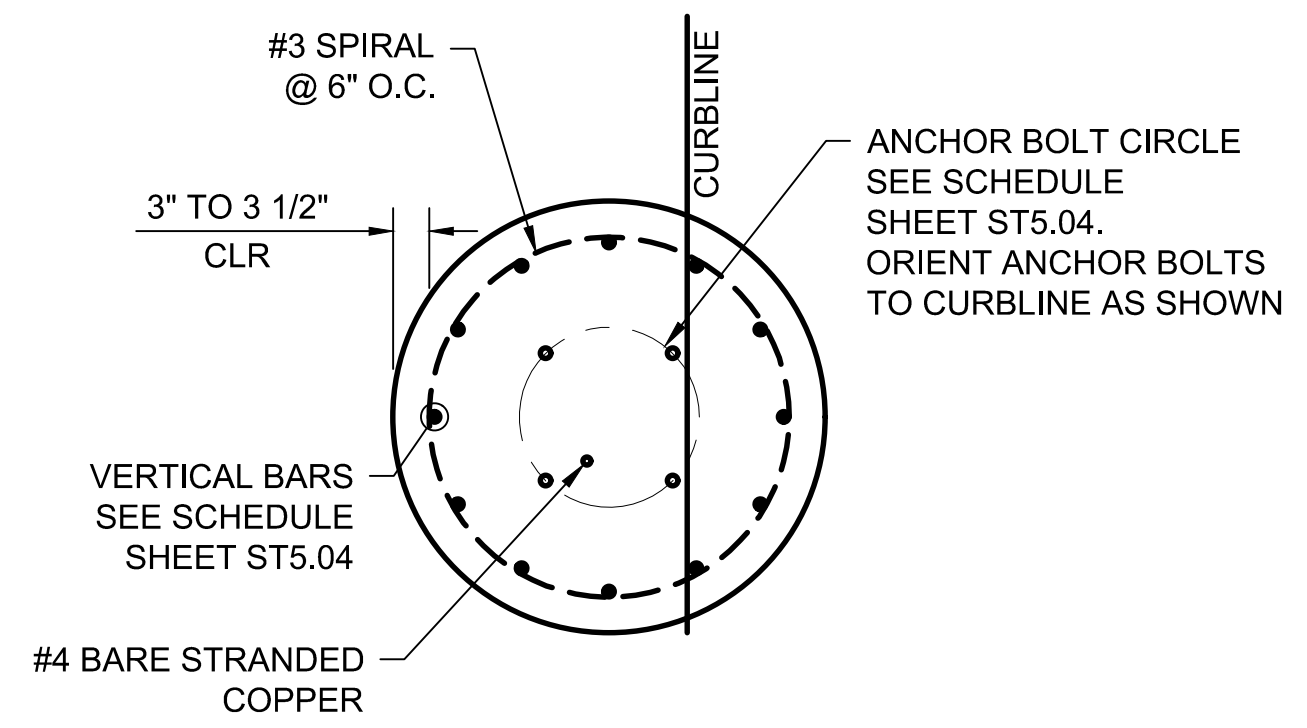

SECTION A
3/4" = 1'-0"

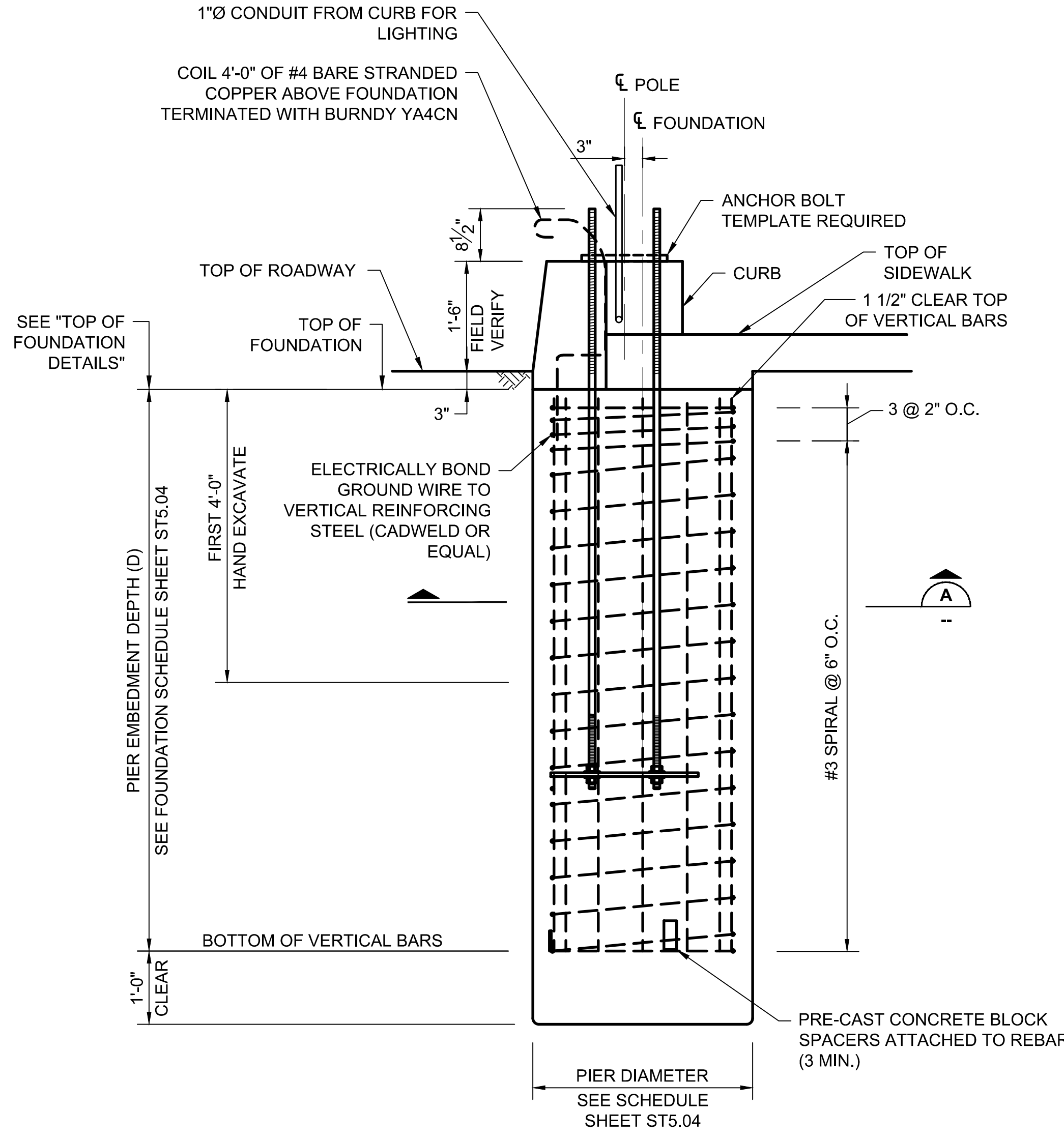

PLAN VIEW
3/4" = 1'-0"

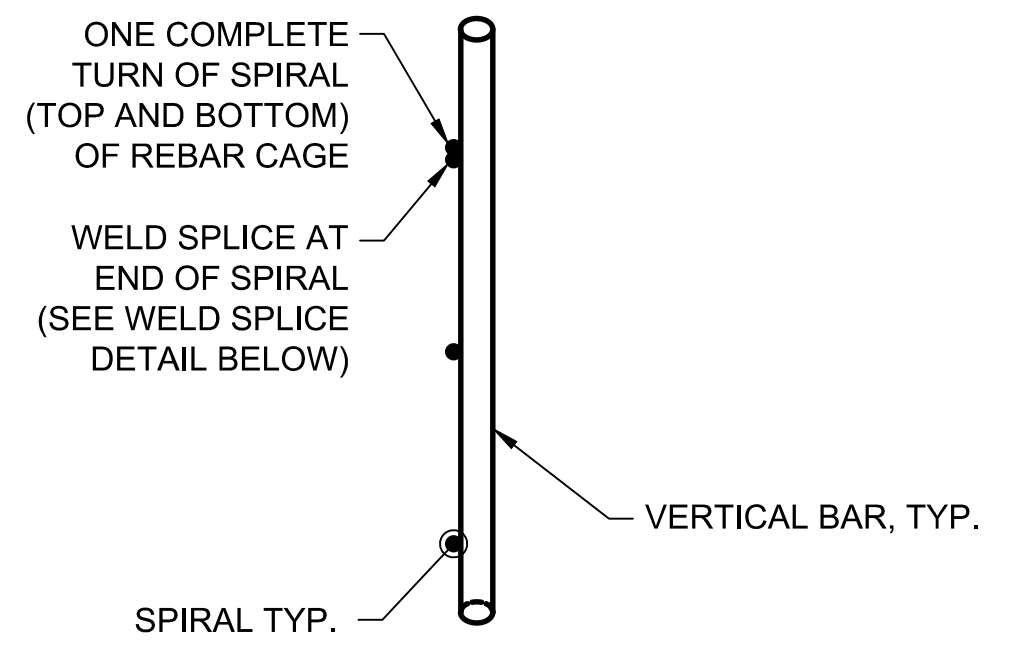

SPIRAL TERMINATION DETAIL
2" = 1'-0"

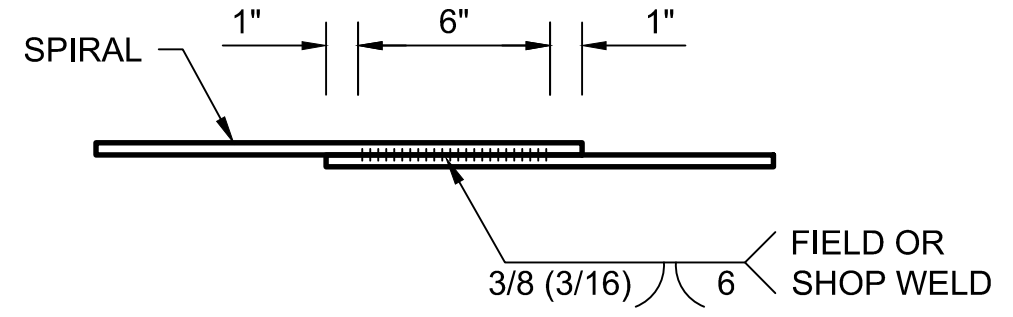

SPIRAL WELD SPlice DETAIL
2" = 1'-0"

NOTE:
SEE SHEET ST5.04 FOR SHAFT DESIGN PARAMETERS AND SPECIFICATIONS.

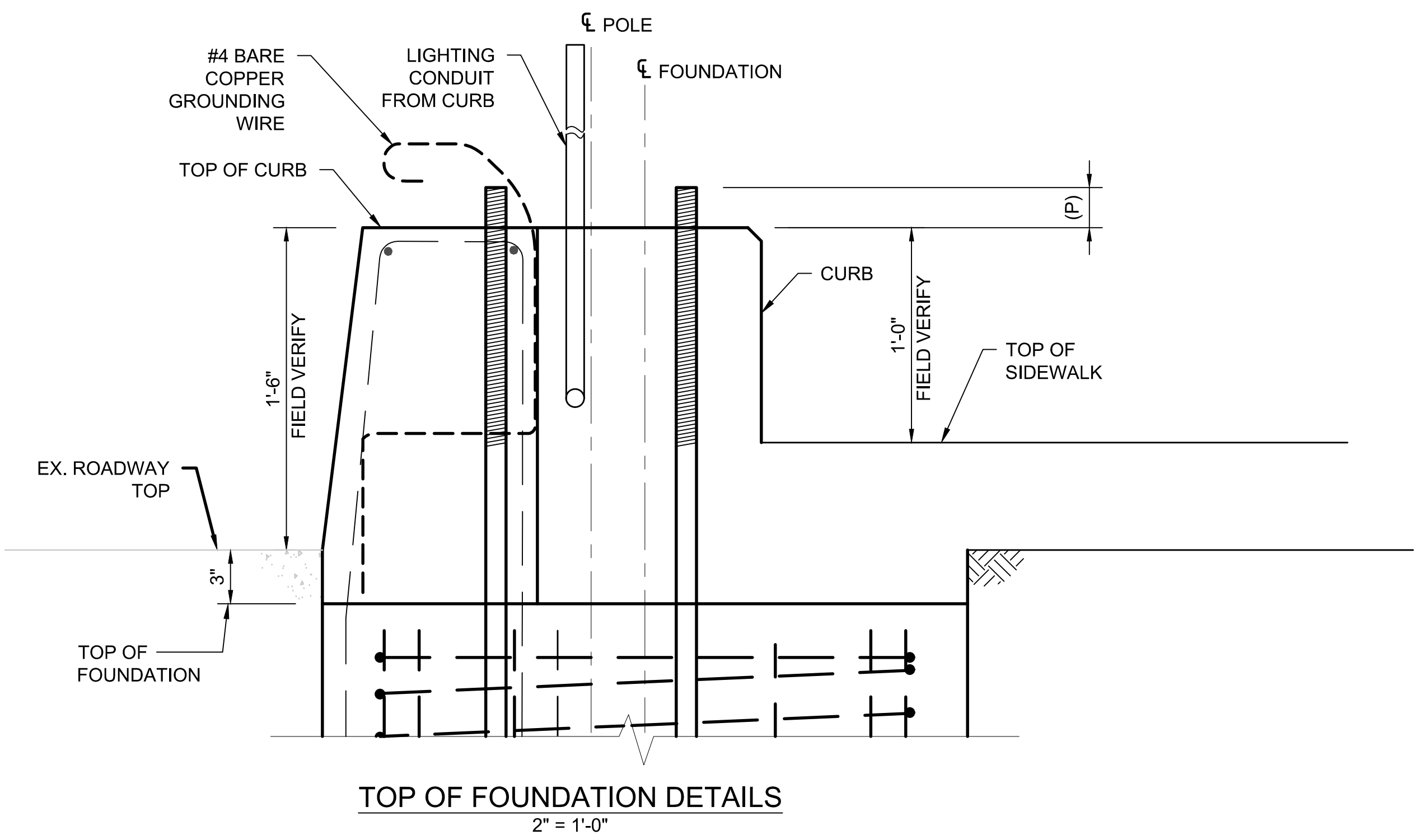

TOP OF FOUNDATION DETAILS
2" = 1'-0"

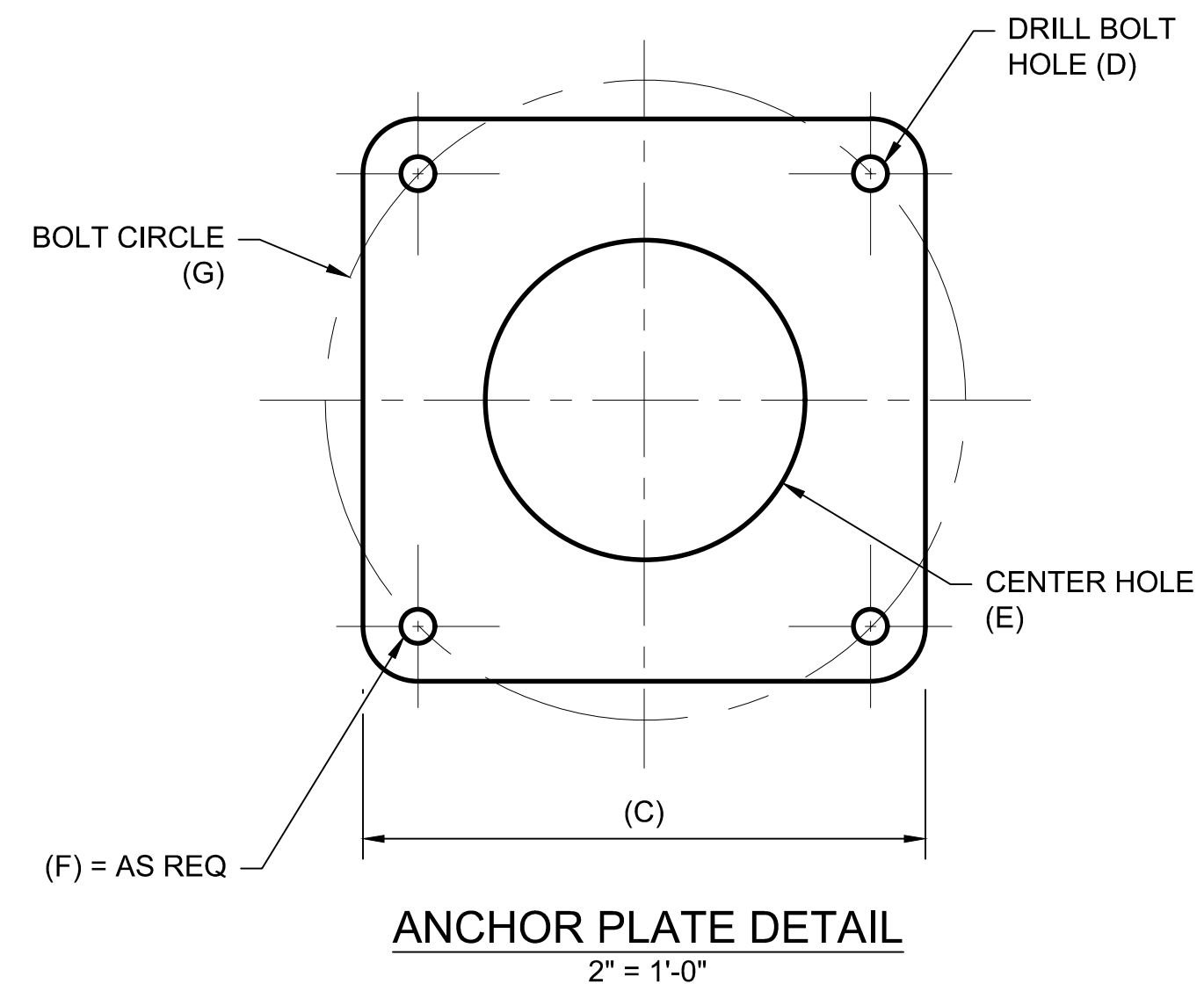

ANCHOR PLATE DETAIL
2" = 1'-0"

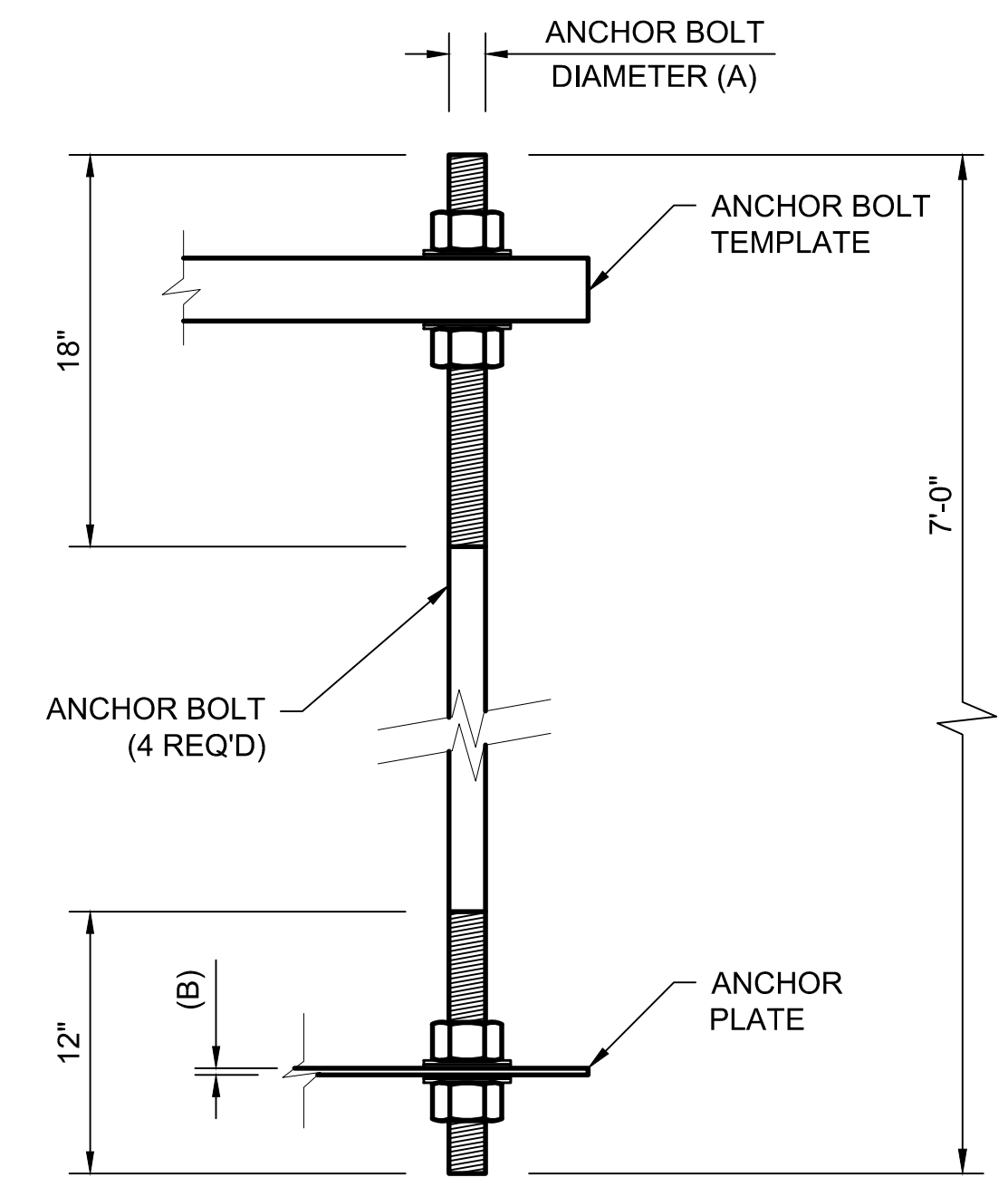

TYPICAL ANCHOR BOLT
1 1/2" = 1'-0"
COMPLETE WITH 4 NUTS
4 FLAT WASHERS
& 1 LOCK WASHER.
SEE SHEET ST5.04 NOTES

Z:\210127\KC University Pole Replacement\CADD\SHEET 12-13 ST5.03-04-SHAFT FOUNDATION DETAILS.dwg | Layout: ST5.03
PLOTTED: Dec 05, 2025 09:00:01 pm By: Jane Wolk
XREFS: \KC\DC-BORDER-RHC Engineering

No.	REVISION	BY	APPD	DATE

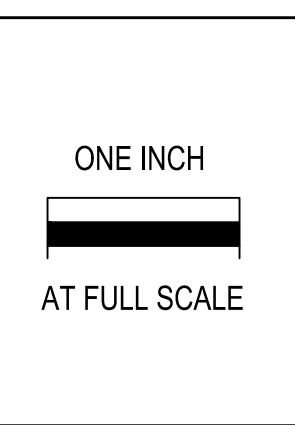

RHC ENGINEERING
WWW.RHCENGINEERING.COM
720 3RD AVE SUITE 1400
SEATTLE WA 98104
PH: 206.623.5984

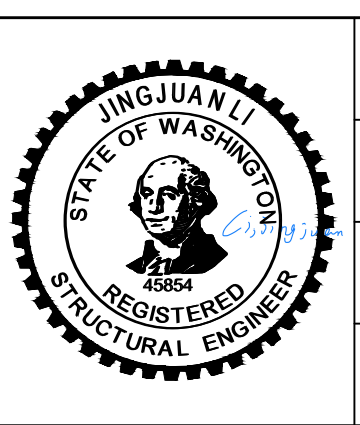

DESIGNED: J. LI	APPROVED: G. FRANCO
DRAWN: T. LOZADA	PROJECT NO.: 1127254
CHECKED: G. CHEN	CONTRACT NO.:



METRO TRANSIT CAPITAL DIVISION
TROLLEY OVERHEAD SYSTEM
UNIVERSITY BRIDGE TROLLEY POLE REPLACEMENT

**POLE SHAFT FOUNDATION
DETAILS - 1**

DATE: DECEMBER 2, 2025
DRAWING NO.: ST5.03
SHEET NO. OF: 12 43

FOUNDATION DETAIL SCHEDULE															
ANCHOR BASE FOUNDATION									ANCHOR BOLT AND ANCHOR PLATE DIMENSIONS (INCHES)						
FOUNDATION TYPE	POLE My STANDARD/MAXIMUM (KIP-FT)	PIER EMBEDMENT DEPTH (D)		PIER DIAMETER	REBAR REQUIREMENTS		BOLT CIRCLE ANCHOR	BOLT PROJ ANCHOR (P)	ANCHOR BOLT DIAMETER (A)	PLATE THICKNESS (B)	PLATE WIDTH (C)	PLATE HOLE (D)	CENTER HOLE (E)	CORNER RADIUS (F)	BOLT CIRCLE (G)
		4 BLOWS PER FT	2 BLOWS PER FT		VERTICAL*	CONTINUOUS TIES									
SA-213-A	110 / 180	9	14	3' - 0"	8 - #8	#3	15"	8 1/2"	1 1/2	3/8	16X16	1 5/8	10 1/2	1 1/2	15

*: ADD (1) #8 VERTICAL BAR FOR GROUNDING.

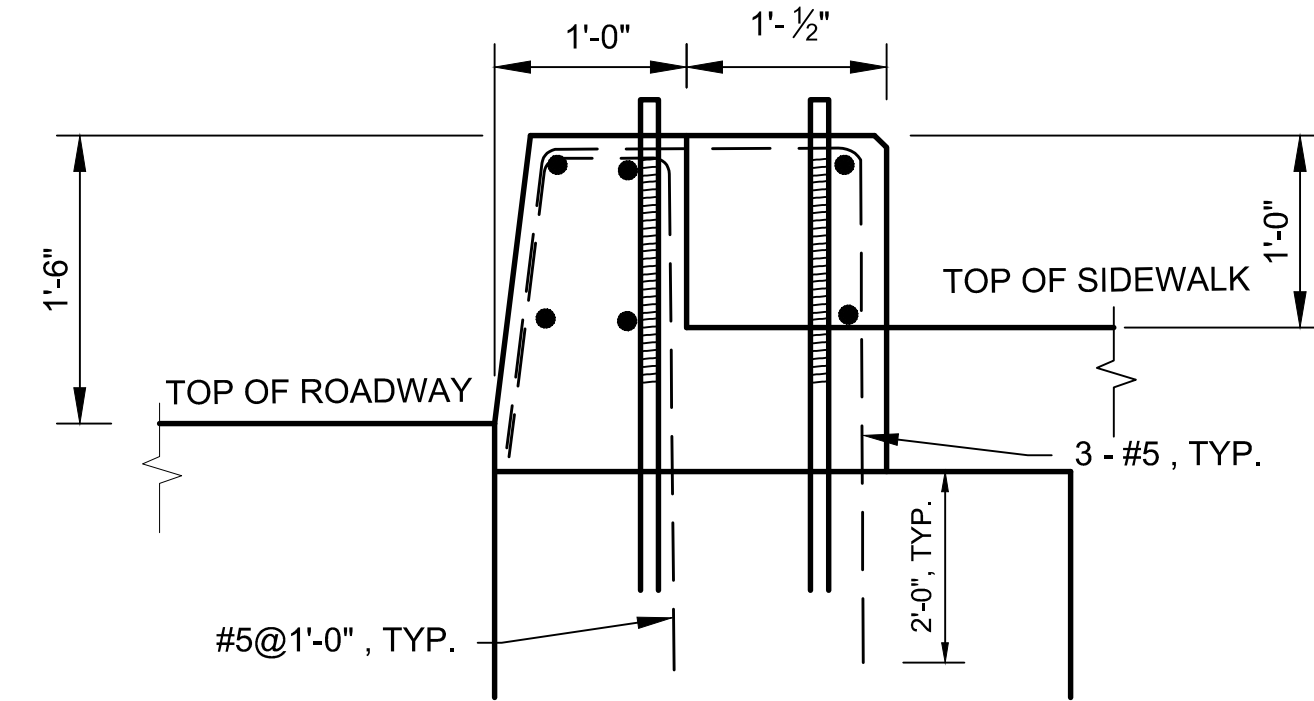

SECTION A
3/4" = 1'-0"

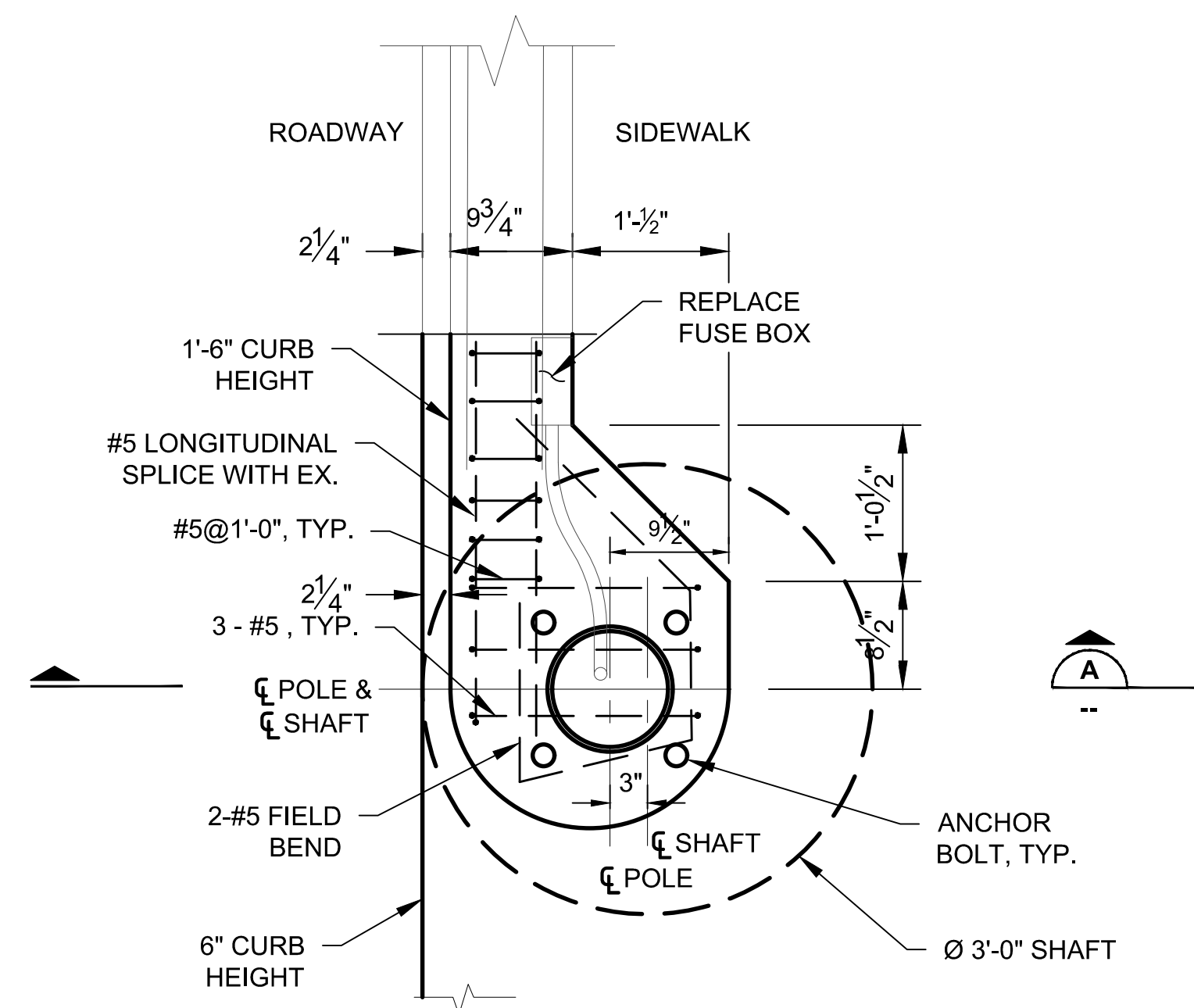

PLAN VIEW
3/4" = 1'-0"

SHAFT FOUNDATION NOTES

- CONCRETE AND REINFORCING STEEL
 - ALL WORK SHALL BE DONE PER SEATTLE SIDEWALK AND STREET PAVING AND RESTORATION RULES AND REGULATIONS IF IN STREET RIGHT OF WAY.
 - CONCRETE SHALL BE CITY OF SEATTLE CLASS 4000P, AND WITH A MINIMUM COMPRESSIVE STRENGTH OF 4000 PSI AT 28 DAYS.
 - ALL REINFORCING BARS SHALL BE DEFORMED BILLET STEEL CONFORMING TO ASTM A706 GRADE 60.
 - MINIMUM CLEAR CONCRETE COVER SHALL BE 3 INCHES.
 - REINFORCING DETAILS AND FABRICATION SHALL BE AS RECOMMENDED IN ACI 315 "DETAILS & DETAILING OF CONCRETE REINFORCEMENT."
 - CONCRETE IS NOT ALLOWED TO FREE FALL MORE THAN 5 FEET DURING PLACEMENT. CONCRETE MUST BE PLACED WITHIN EITHER A CONCRETE PUMP OR WITH THE USE OF A TREMIE TO AVOID FREE FALLING MORE THAN 5 FEET.
- ANCHOR PLATES, BOLTS, NUTS AND WASHERS
 - ANCHOR BOLTS INCLUDING NUTS AND FLAT WASHERS SHALL CONFORM TO ASTM F1554 GRADE 105 CLASS 2A INCLUDING SUPPLEMENTARY REQUIREMENTS S2, S3 AND S4. THREADS SHALL CONFORM TO THE ANSI STANDARD B1.1 FOR UNC THREAD. ANCHOR BOLTS SHALL HAVE MINIMUM 18 INCHES OF THREAD ON EXPOSED END AND 12 INCHES OF THREAD ON THE EMBEDDED END.
 - ANCHOR PLATES SHALL CONFORM TO ASTM A36.
- GALVANIZING
 - ANCHOR PLATES, ANCHOR BOLTS, ANCHOR BOLT NUTS AND WASHERS SHALL BE HOT-DIP GALVANIZED IN CONFORMANCE TO ASTM A153 OR ASTM A123.
- SOIL
 - EMBEDMENT DEPTH IS ADEQUATE FOR THREE TIMES THE WORKING MOMENT IN COHESIVE SOILS OF C=1000 PSF AND $\phi=0^\circ$ OR BETTER AND COHESIONLESS SOILS OF C=0 PSF AND $\phi=26^\circ$ OR BETTER.
- SUBMITTALS
 - REINFORCING STEEL SHOP DRAWINGS AND CERTIFICATE OF COMPLIANCE.
 - CONCRETE MIX PROPORTIONS, ADMIXTURES AND SLUMP.
 - ANCHOR PLATE, ANCHOR BOLT, ANCHOR BOLT NUTS AND WASHERS CERTIFICATES OF COMPLIANCE.
 - A TEST REPORT SHALL BE PROVIDED IN ACCORDANCE WITH ASTM F1554-99 AND SUPPLEMENTARY REQUIREMENTS.
- INSPECTION
 - CONCRETE SHALL NOT BE PLACED UNTIL THE KING COUNTY PROJECT REPRESENTATIVE HAS INSPECTED THE EXCAVATION, THE GROUNDING, THE ANCHOR BOLTS, AND THE PLACEMENT OF THE REINFORCING BAR CAGE.
- ANCHOR BOLT SETTING
 - COVER EXPOSED ANCHOR BOLT THREADS AND NUTS WITH AT LEAST 3 LAYERS OF PLASTIC TAPE BEFORE PLACING CONCRETE.
 - ANCHOR BOLT TEMPLATE SHALL BE USED TEMPORARILY AT THE TOP OF ANCHOR BOLTS FOR ACCURATE POSITIONING AND ALIGNING.
- CONDUIT
 - CONDUIT FROM FOUNDATION SHALL BE SCHEDULE 80 PVC. CONDUIT BENDS SHALL HAVE A MINIMUM RADIUS OF 12".
- SEE SHEET ST5.03 FOR SHAFT DETAILS.

Z:\210127\KC University Pole Replacement\CADD\SHEET 12-13 ST5.03-04 SHAFT FOUNDATION DETAILS.dwg | Layout: ST5.04
 PLOTTED: Jan 02, 2025 09:52:48am By: Jamie Work
 XREFS: KC DC-BORDER-RHC Engineering IMAGES

No.	REVISION	BY	APPD	DATE

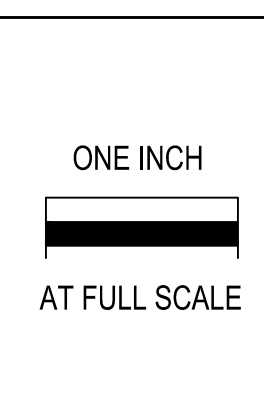

RHC ENGINEERING
 WWW.RHCENGINEERING.COM
 720 3RD AVE SUITE 1400
 SEATTLE WA 98104
 PH: 206.623.5984

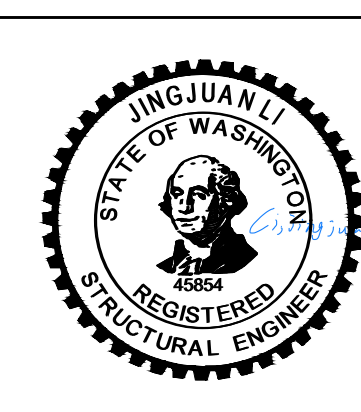

DESIGNED: J. LI	APPROVED: G. FRANCO
DRAWN: T. LOZADA	PROJECT NO: 1127254
CHECKED: G. CHEN	CONTRACT NO: -
CHECKED: -	



METRO TRANSIT CAPITAL DIVISION
 TROLLEY OVERHEAD SYSTEM
 UNIVERSITY BRIDGE TROLLEY POLE REPLACEMENT

**POLE SHAFT FOUNDATION
 DETAILS - 2**

DATE: DECEMBER 2, 2025
DRAWING NO: ST5.04
SHEET NO. OF 13 43

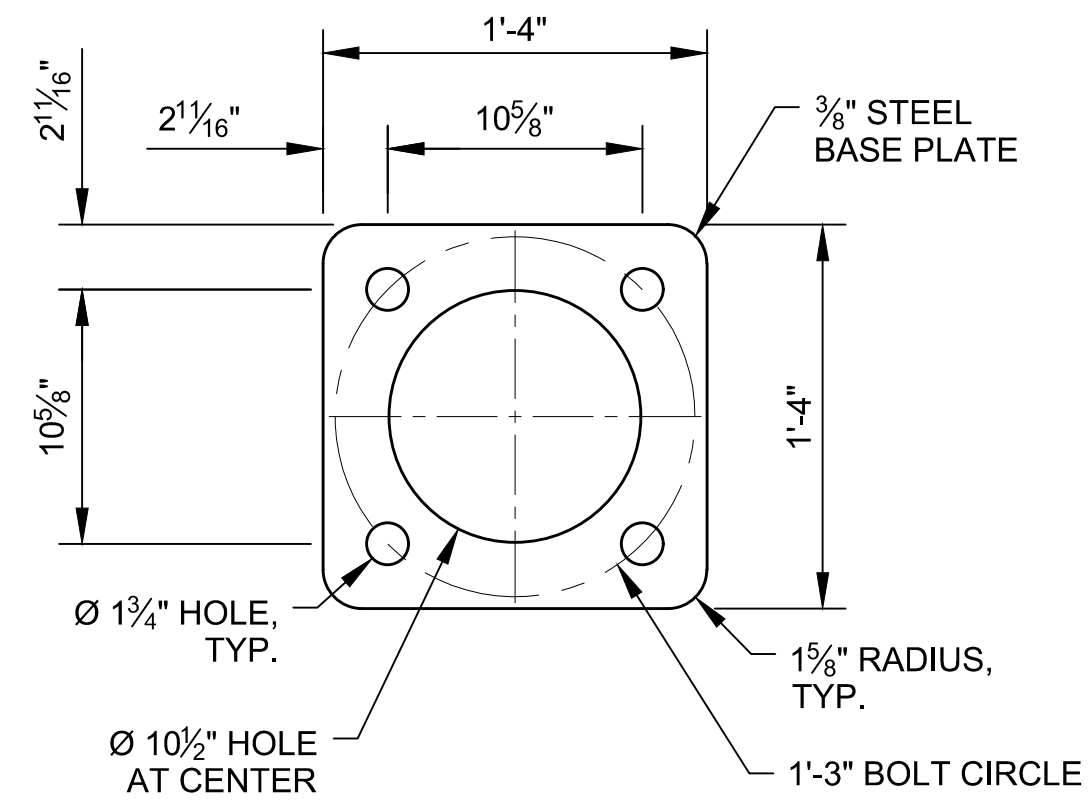

TOP ANCHOR PLATE

DETAIL 2
 1 1/2" = 1'-0" ST5.01
 ST5.02

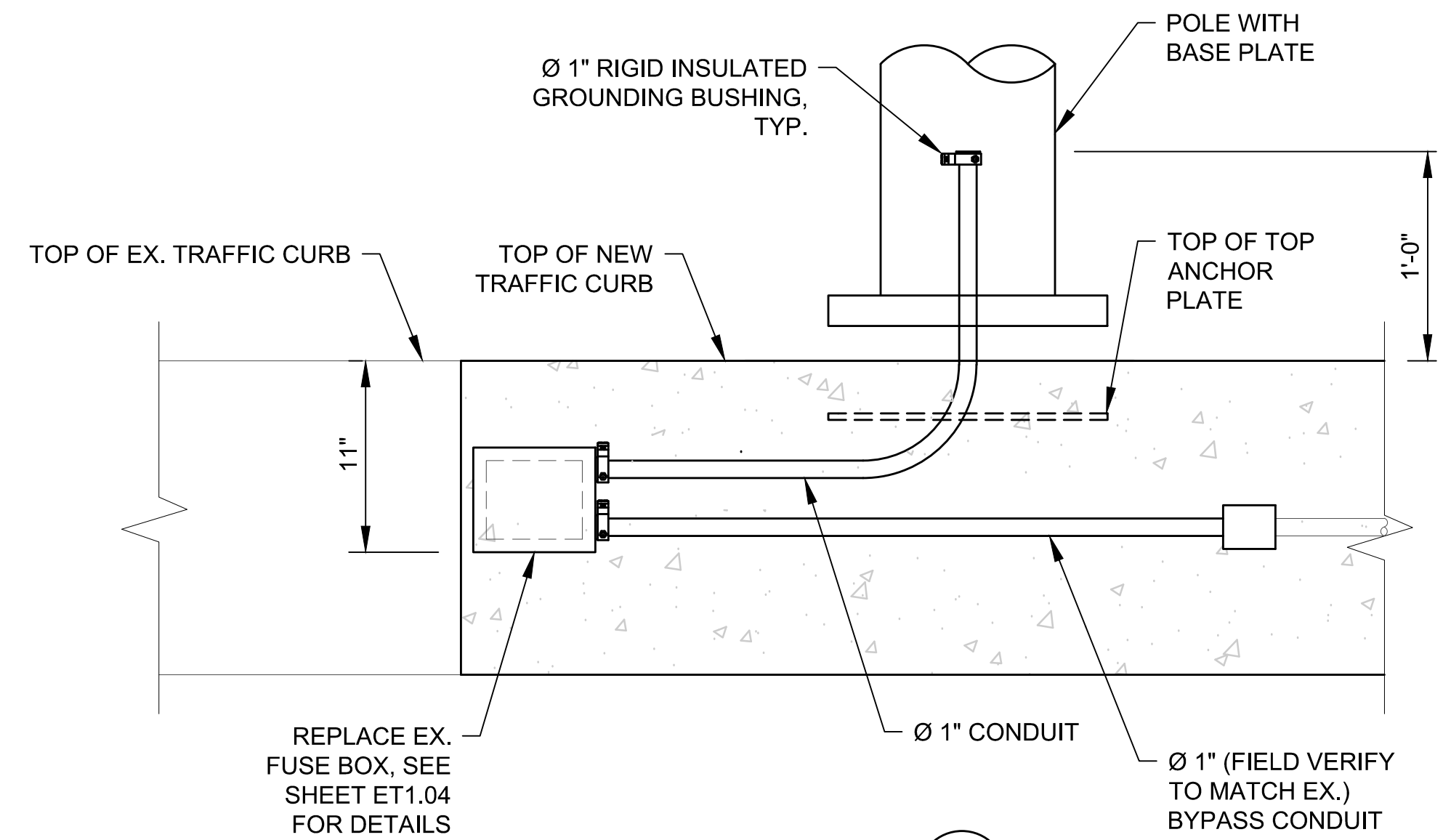

CONDUIT DETAIL 5
 1 1/2" = 1'-0" ST5.01
 ST5.02

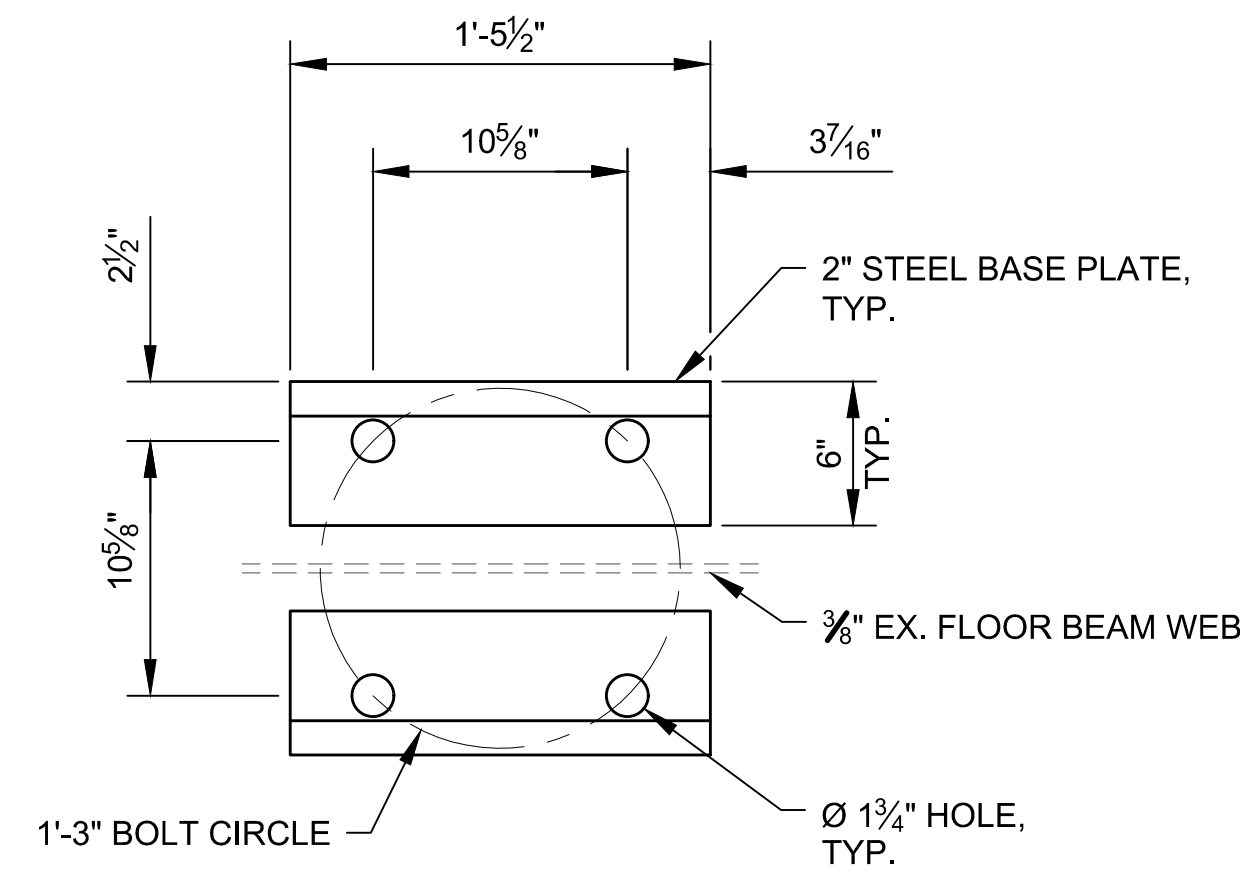

**STEEL ANCHOR PLATE 1
 AT STEEL BRIDGE**

DETAIL 3
 1 1/2" = 1'-0" ST5.01

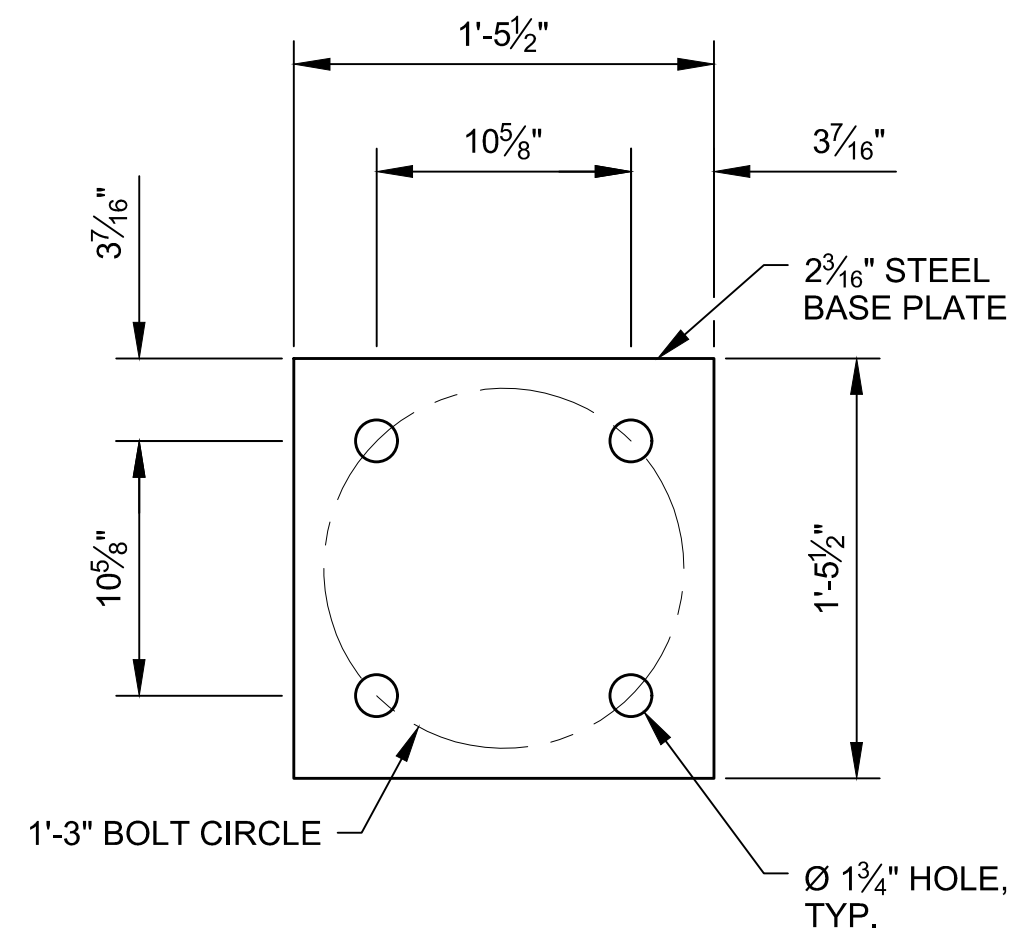

**STEEL ANCHOR PLATE 2
 AT CONCRETE BRIDGE**

DETAIL 4
 1 1/2" = 1'-0" ST5.02

Z:\210127\KC University Pole Replacement\CADD\Sheet 14 ST5.05 STEEL ANCHOR PLATE AND BASE PLATE DETAILS.dwg | Layout: ST5.05
 PLOT FILED: Dec 03, 2025 04:26:47 pm By: Jane Work
 XREFS: KCDC-BORDER-RHC Engineering IMAGES

No.	REVISION	BY	APP'D	DATE

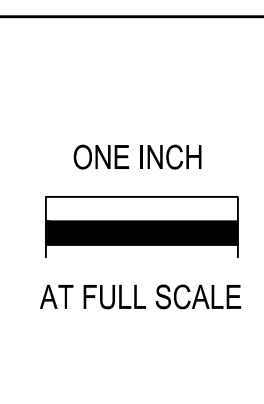

RHC ENGINEERING
 WWW.RHCENGINEERING.COM
 720 3RD AVE SUITE 1400
 SEATTLE WA 98104
 PH: 206.623.5984

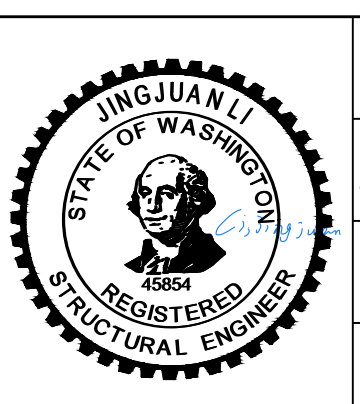

DESIGNED: J. LI	APPROVED: G. FRANCO
DRAWN: T. LOZADA	PROJECT NO: 1127254
CHECKED: G. CHEN	CONTRACT NO: -
CHECKED: -	



METRO TRANSIT CAPITAL DIVISION
 TROLLEY OVERHEAD SYSTEM
 UNIVERSITY BRIDGE TROLLEY POLE REPLACEMENT

**POLE ANCHOR PLATE AND
 BASE PLATE DETAILS**

DATE: DECEMBER 2, 2025
DRAWING NO: ST5.05
SHEET NO. OF 14 43

Z:\210127\KC University Pole Replacement\CADD\SHEET 15 ST5.06 POLE REPLACEMENT AND INSTALLATION DETAILS.dwg | Layout: ST5.06
 PLOT FILED: Dec 05, 2025 04:54:33pm By: Jane Work
 XREFS: KC DDC-BORDER-RHC Engineering IMAGES

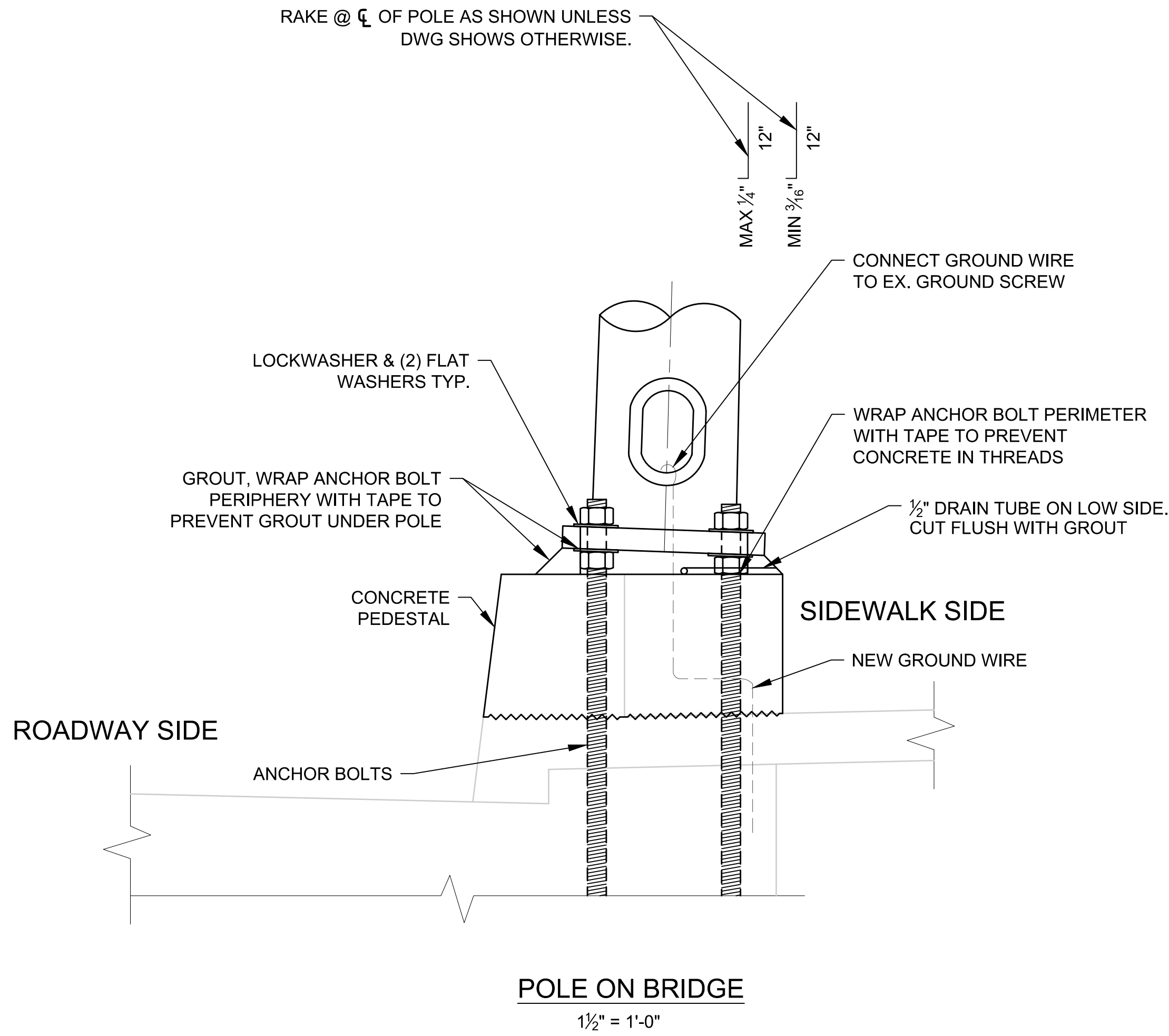

POLE ON BRIDGE
 1/2" = 1'-0"

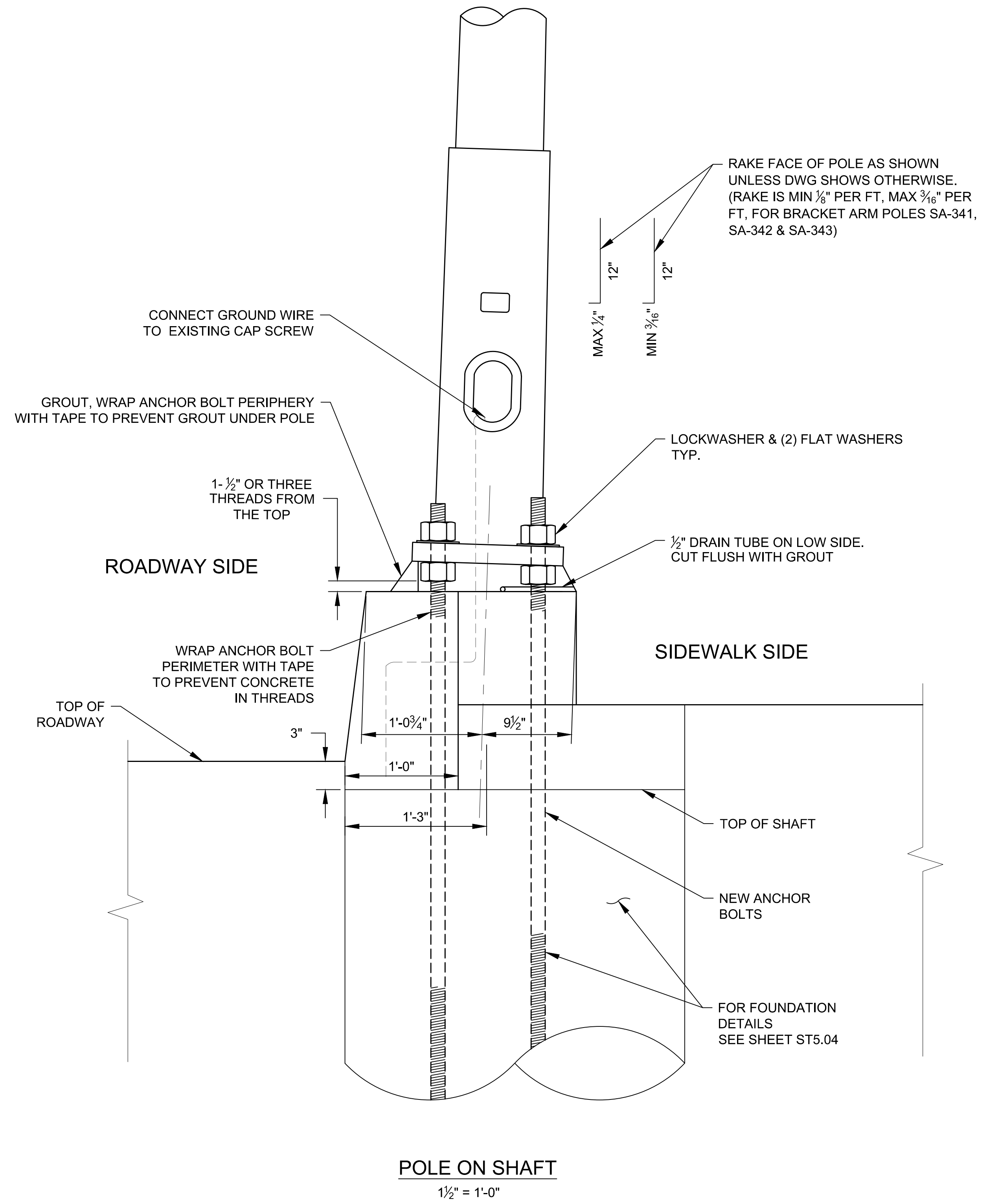

POLE ON SHAFT
 1/2" = 1'-0"

No.	REVISION	BY	APP'D	DATE

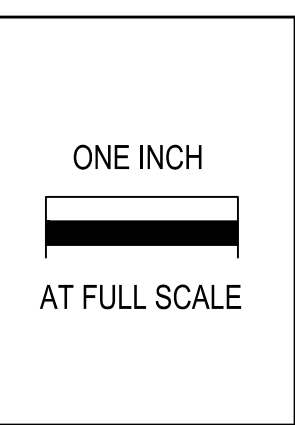

RHC ENGINEERING
 WWW.RHCENGINEERING.COM
 720 3RD AVE SUITE 1400
 SEATTLE WA 98104
 PH: 206.623.5984

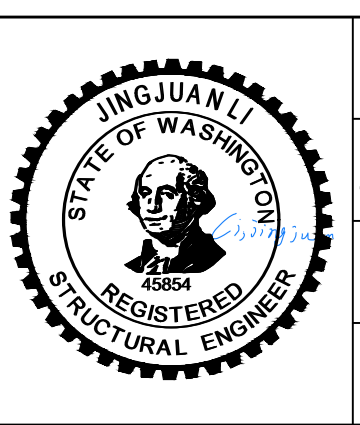

DESIGNED: J. LI	APPROVED: G. FRANCO
DRAWN: T. LOZADA	PROJECT NO: 1127254
CHECKED: G. CHEN	CONTRACT NO: -
CHECKED: -	-



METRO TRANSIT CAPITAL DIVISION
 TROLLEY OVERHEAD SYSTEM
 UNIVERSITY BRIDGE TROLLEY POLE REPLACEMENT
POLE INSTALLATION DETAILS

DATE: DECEMBER 2, 2025
DRAWING NO: ST5.06
SHEET NO. OF 15 43

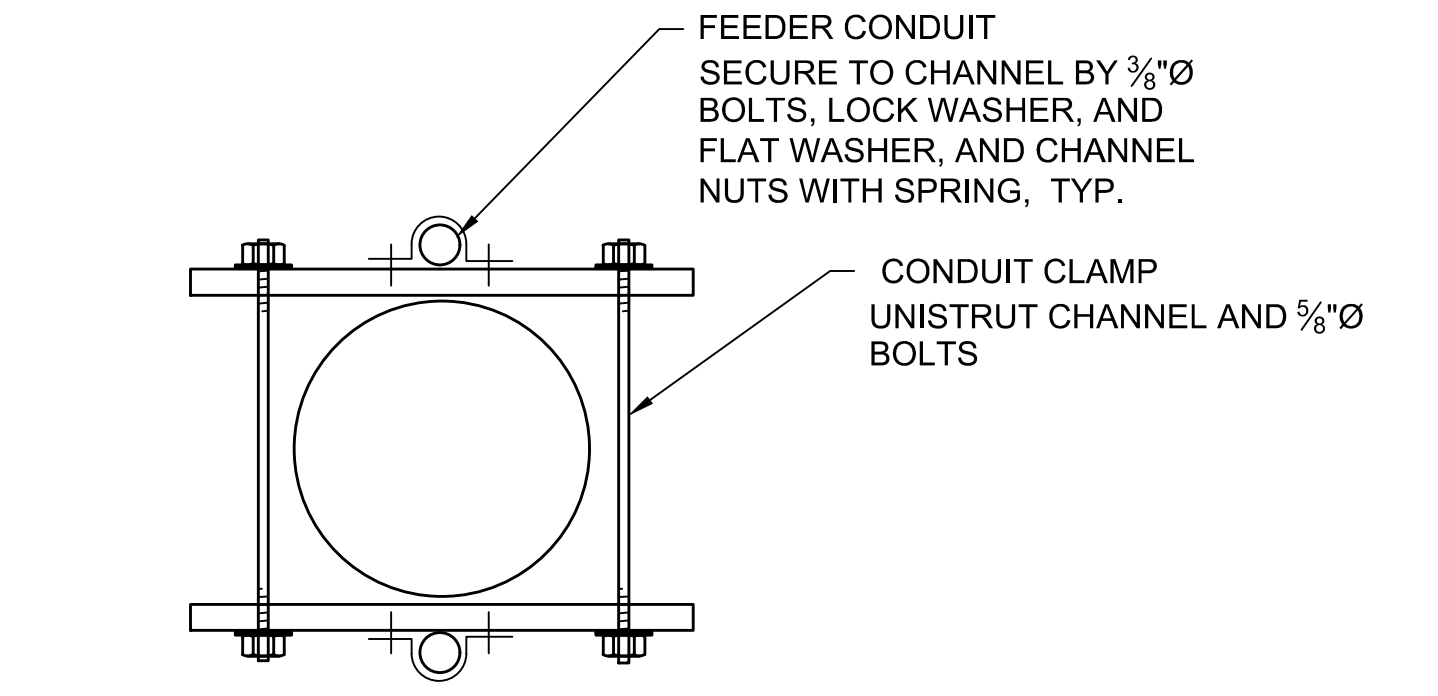
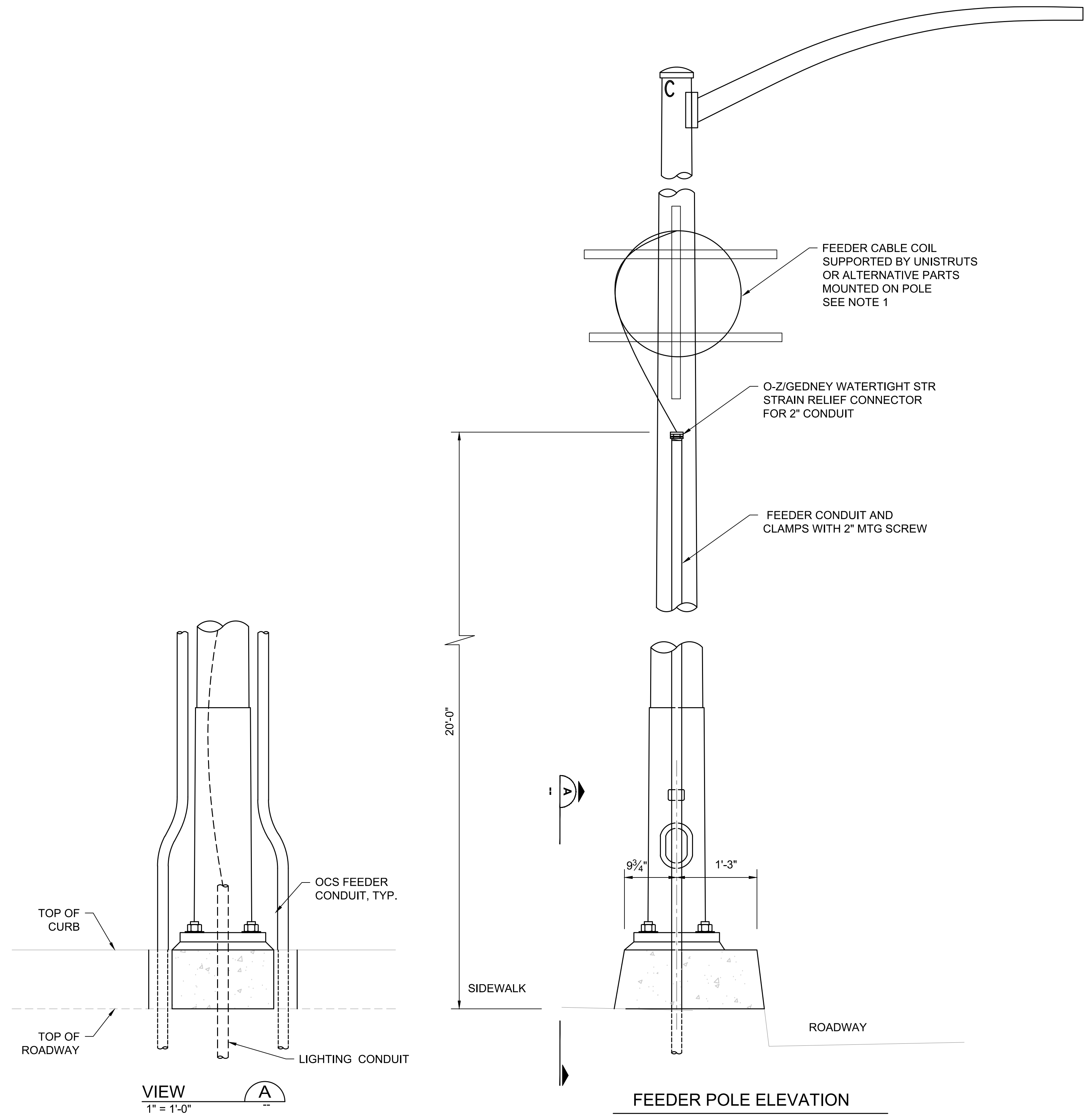

DOUBLE FEEDER CONDUIT CLAMP

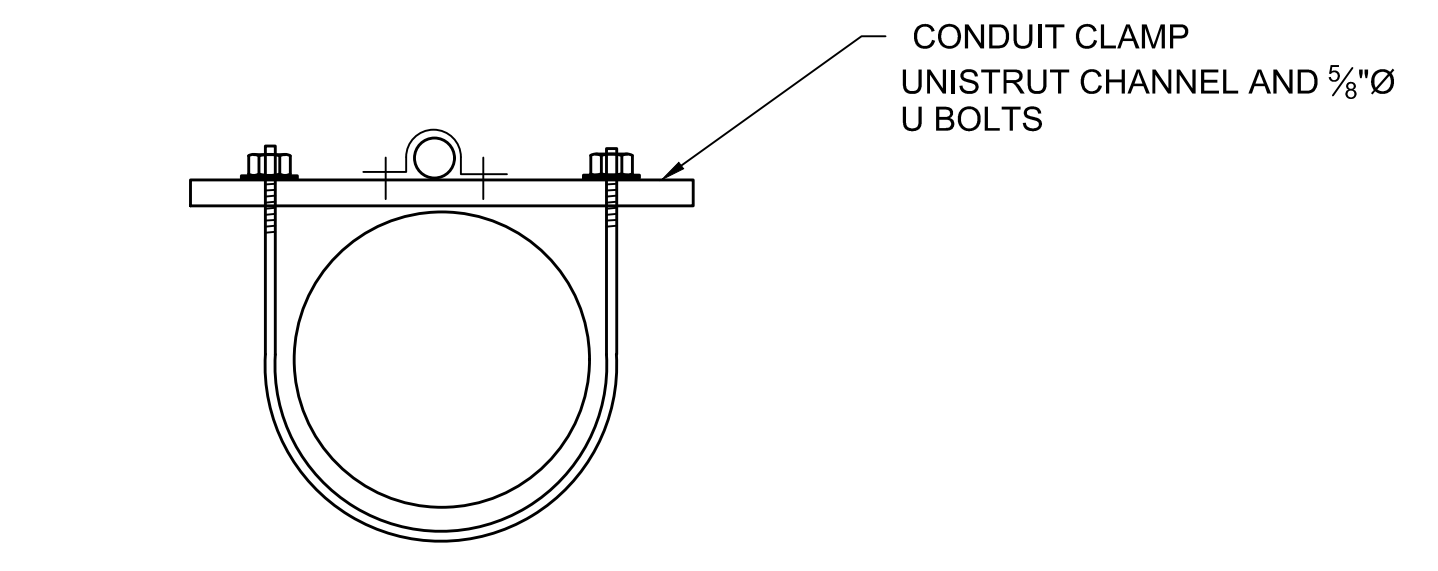

SINGLE FEEDER CONDUIT CLAMP

NOTES:

1. FEEDER CABLE SHALL INCLUDE SUFFICIENT LENGTH TO CONNECT FEED SPAN WITH VAULT SHOWN ON DRAWINGS. COIL 20' AT VAULT END, AND COIL 10' AT FEED SPAN END.
2. CONDUIT AND CLAMPS SHALL BE PLACED NEAR TOP AND BASE OF THE POLE AND SHALL MEET REQUIREMENTS OF SEATTLE CITY LIGHT SPECIFICATIONS. THE CLAMP SHALL BE MINIMUM 8'-0" FROM SIDEWALK GROUND.
3. CONTRACTOR SHALL NOTIFY KING COUNTY PROJECT REPRESENTATIVE MINIMUM 15 DAYS PRIOR TO FEEDER CABLE PLACEMENT.

Z:\210127\KC University Pole Replacement\CADD\SHEET 16 ST5.07 Feeder pole details.dwg | Layout: ST5.07
 PLOT FILED: Dec 03, 2025 09:42:27 pm | By: Jane Work
 XREFS: KC DCC-BORDER-RHC Engineering IMAGES

No.	REVISION	BY	APP'D	DATE

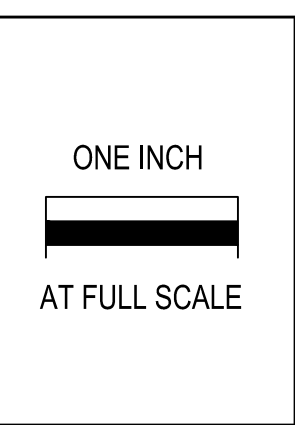

RHC ENGINEERING
 WWW.RHCENGINEERING.COM
 720 3RD AVE SUITE 1400
 SEATTLE WA 98104
 PH: 206.623.5984

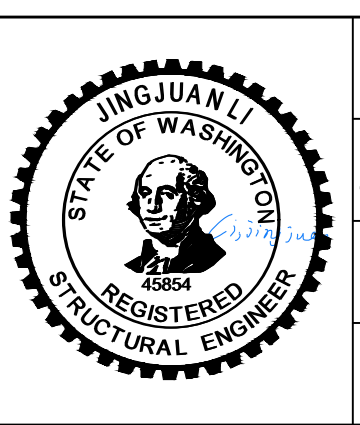

DESIGNED: J. LI	APPROVED: G. FRANCO
DRAWN: T. LOZADA	PROJECT NO: 1127254
CHECKED: G. CHEN	CONTRACT NO: -
CHECKED: -	



METRO TRANSIT CAPITAL DIVISION
 TROLLEY OVERHEAD SYSTEM
 UNIVERSITY BRIDGE TROLLEY POLE REPLACEMENT

FEEDER POLE DETAILS

DATE: DECEMBER 2, 2025
DRAWING NO: ST5.07
SHEET NO. OF 16 43

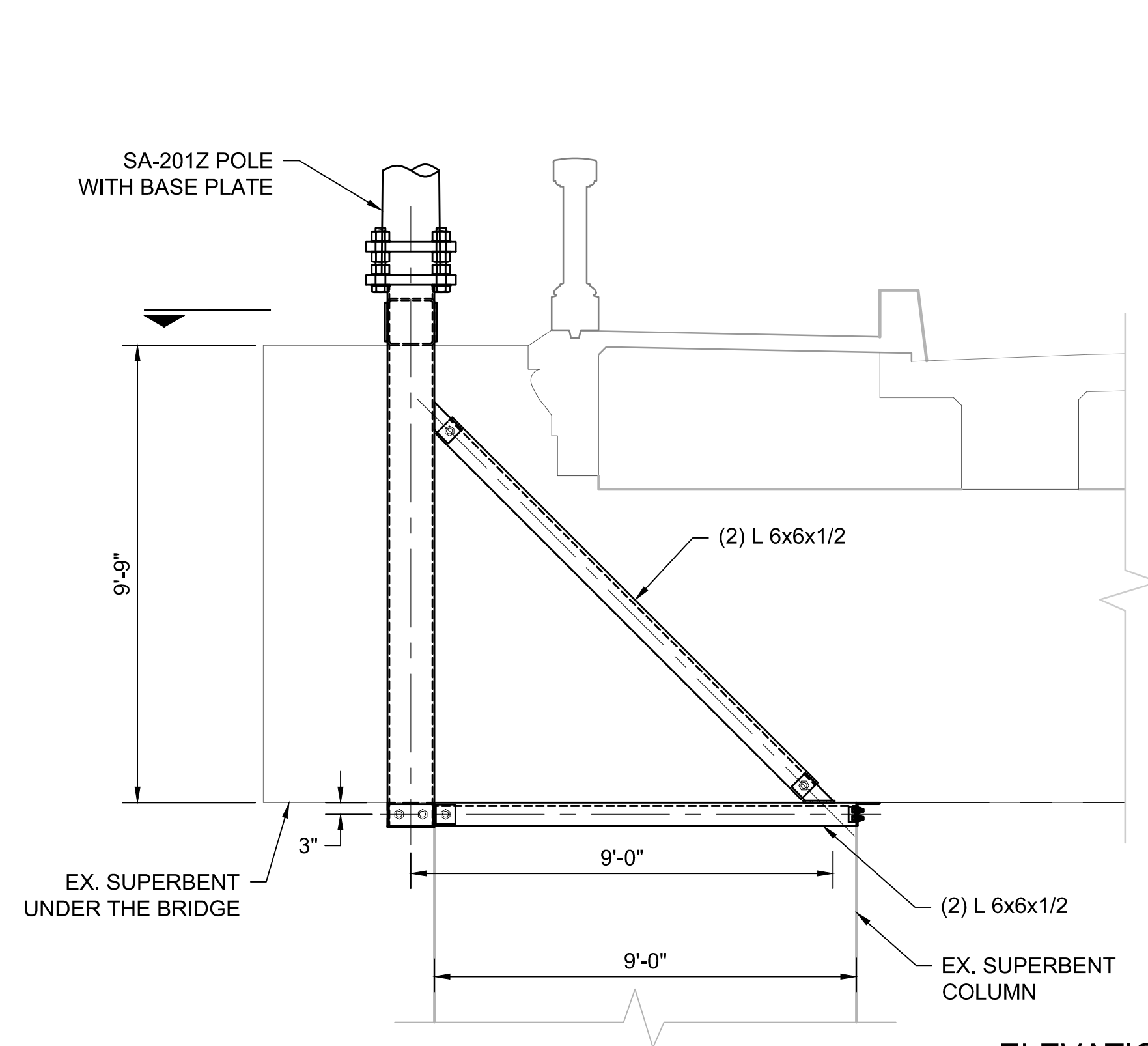

ELEVATION LOOKING NORTH
SYMMETRIC ON BOTH ENDS

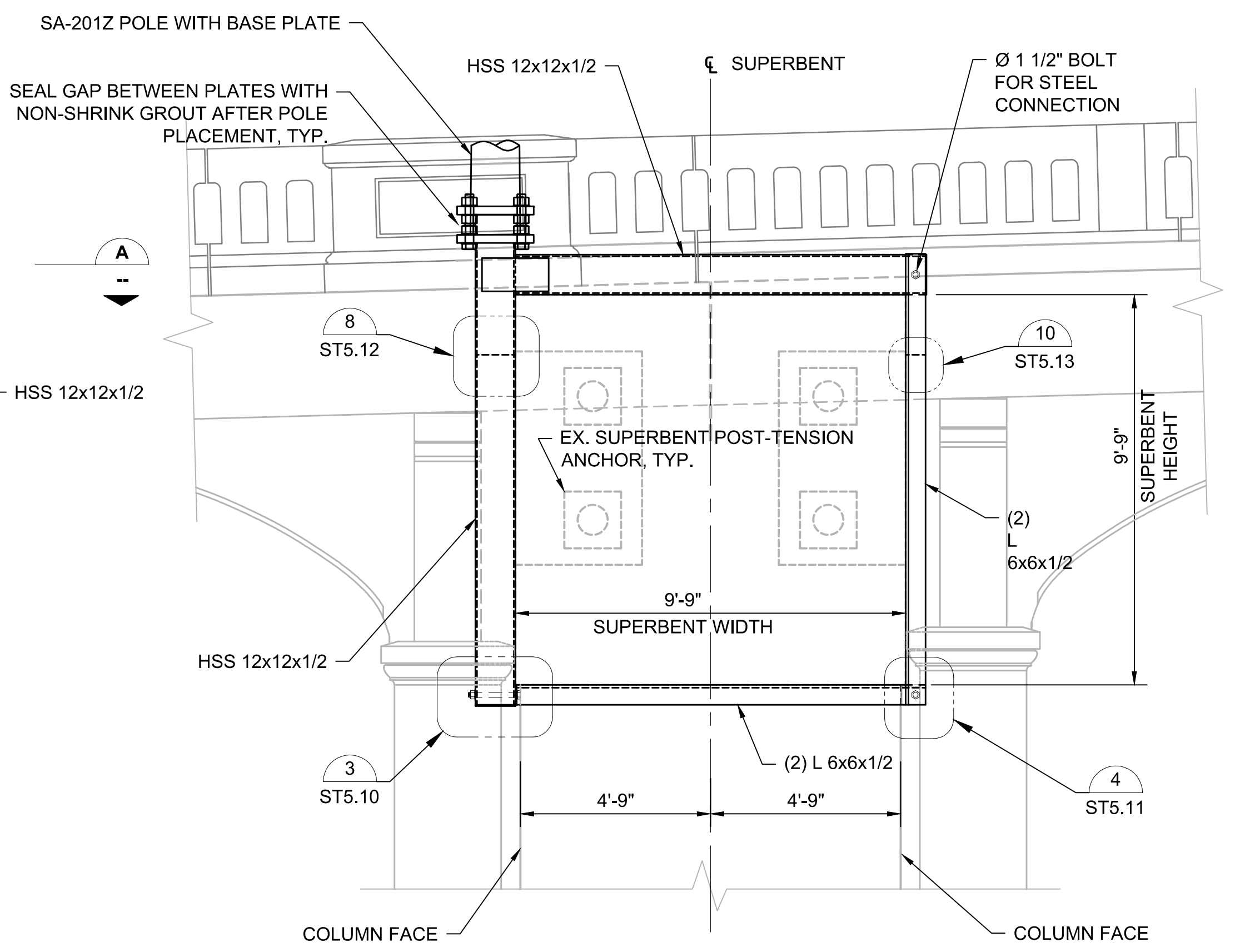
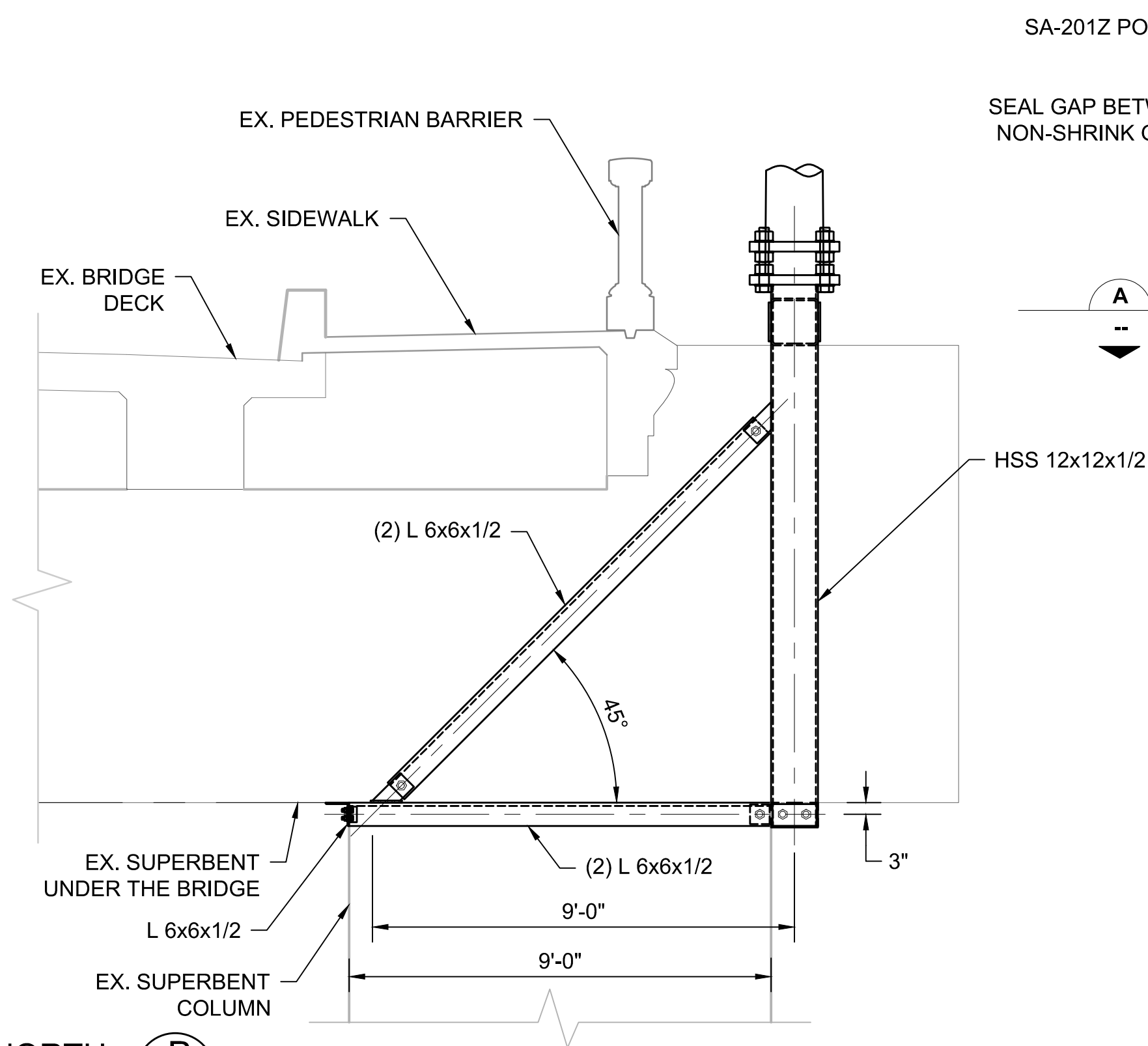

SECTION VIEW

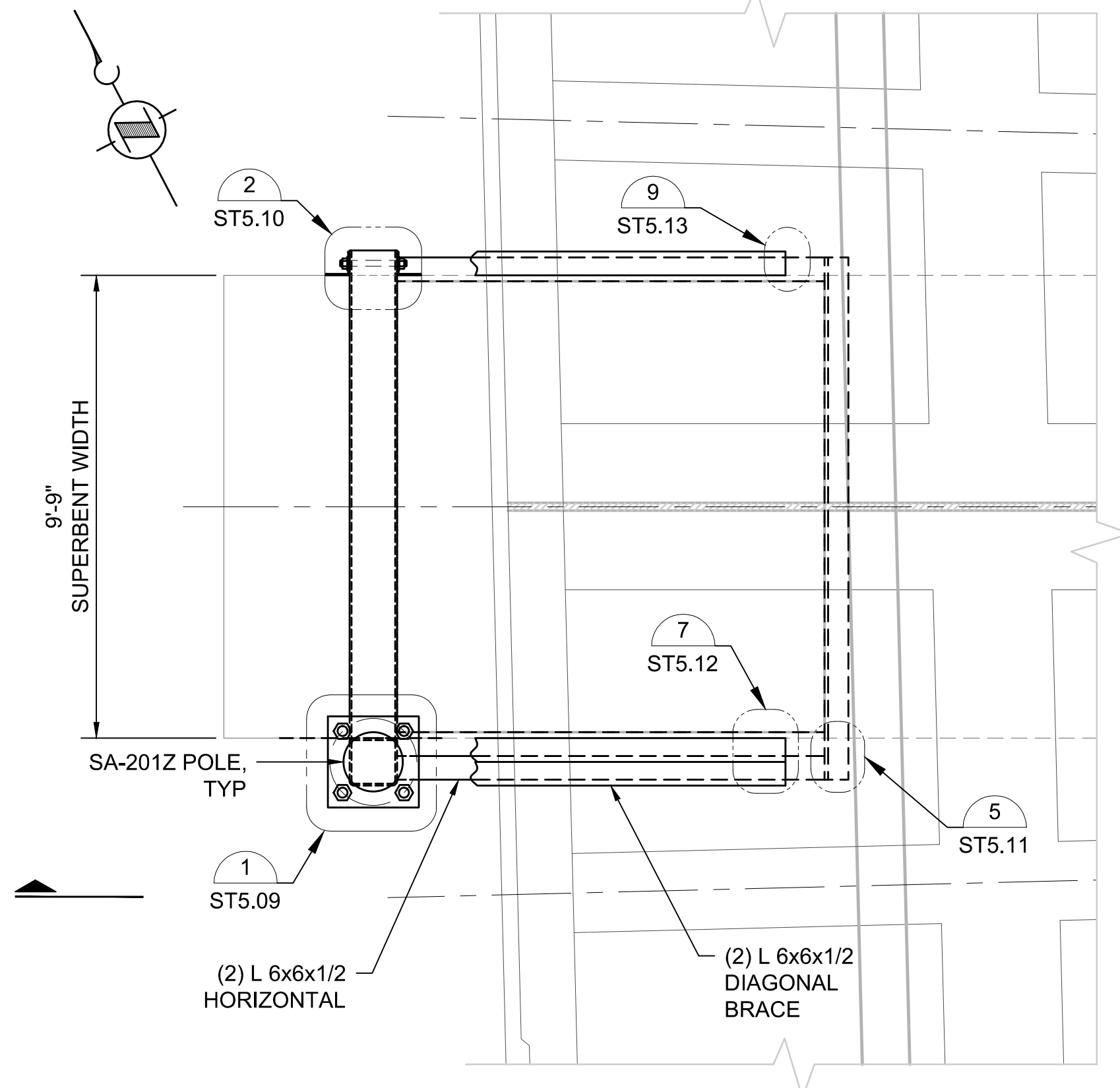

PLAN VIEW
SYMMETRIC AT CL BRIDGE

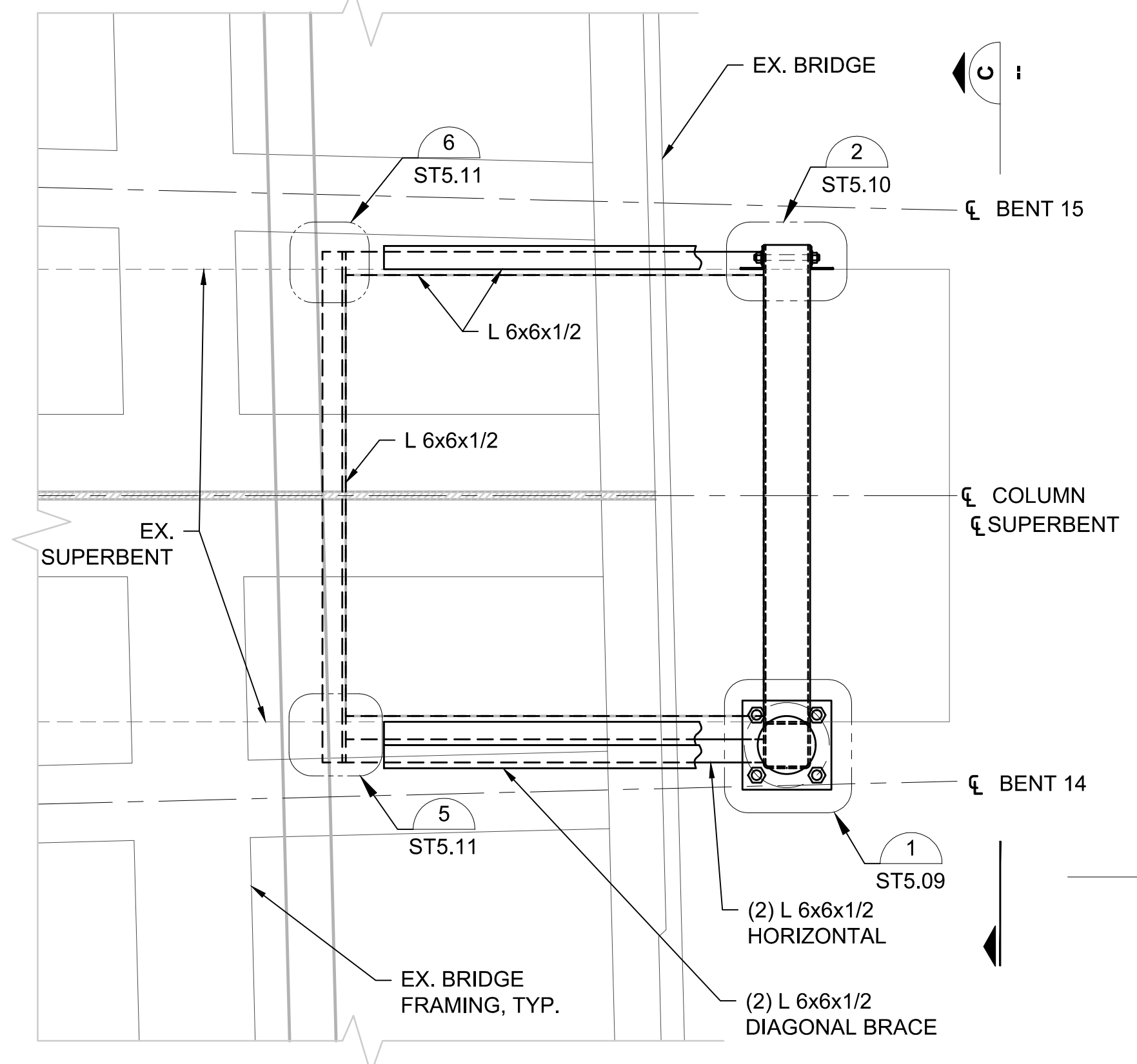

NOTES:

1. FIELD VERIFY ALL EXISTING DIMENSIONS AND CONDITIONS PRIOR TO FABRICATION AND CONSTRUCTION. STEEL FRAMING MUST BE FIT IN SHOP BASED ON VERIFIED ACTUAL DIMENSIONS AND DISSEMBLE FOR FILED DELIVERY. USE GROUT WHEN NEEDED TO MAINTAIN MEMBERS HORIZONTAL AND VERTICAL EXCEPT THE DIAGONAL MEMBERS.
2. ALL STEEL SHALL BE ASTM A572 GRADE 50 HOT DIP GALVANIZED. ALL BOLTS SHALL BE ASTM A325 TYPE 1 GALVANIZED, ALL NUTS SHALL BE ASTM A563 GRADE DH GALVANIZED, ALL WASHERS SHALL BE ASTM F436. ALL BOLTS, NUTS, AND WASHERS SHALL BE GALVANIZED IN ACCORDANCE WITH THE PROVISION OF AASHTO M232.
3. ALL WELDING SHALL BE MADE IN SHOP, MINIMUM FILLET WELD SIZE SHALL BE 1/2", UNLESS NOTED OTHERWISE.
4. DRILLING INTO EXISTING POST-TENSION SUPERBENT IS NOT ALLOWED. FILL GAP BETWEEN STEEL AND CONCRETE WITH NON-SHRINK GROUT FOR A TIGHT FIT, TYP.

Z:\210127\KC University Pole Replacement\CADD\SHEET 17-22 ST5.08-13 SUPERBENT POLE MOUNT DETAILS.dwg | Layout: ST5.08
 PLOTTED: Dec 05, 2025 05:20:10pm By: Jane Wolk
 XREFS: KCDC-BORDER-RHC Engineering, 3D DEAD END POLE AT SIDE OF SUPERBENT IMAGES

No.	REVISION	BY	APP'D	DATE

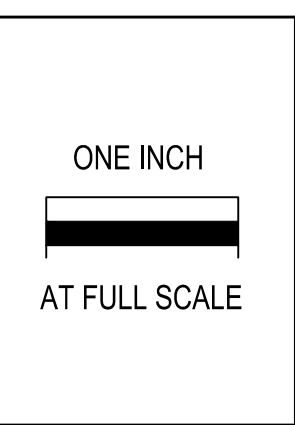

RHC ENGINEERING
 WWW.RHCENGINEERING.COM
 720 3RD AVE SUITE 1400
 SEATTLE WA 98104
 PH: 206.623.5984

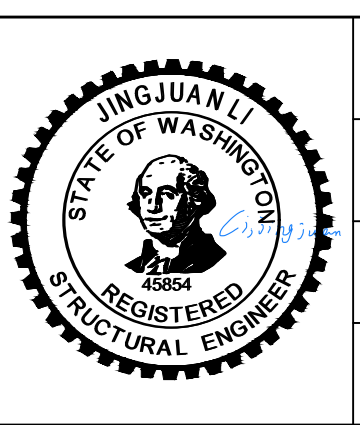

DESIGNED: J. LI	APPROVED: G. FRANCO
DRAWN: T. LOZADA	PROJECT NO: 1127254
CHECKED: G. CHEN	CONTRACT NO: -
CHECKED: -	



METRO TRANSIT CAPITAL DIVISION
 TROLLEY OVERHEAD SYSTEM
 UNIVERSITY BRIDGE TROLLEY POLE REPLACEMENT
**SUPERBENT POLE MOUNTING
 DETAILS - 1**

DATE: DECEMBER 2, 2025
SCALE 3/8" = 1'-0"
DRAWING NO: ST5.08
SHEET NO. OF 17 43

Z:\210127\KC University Pole Replacement\CADD\SHEET 17-22 ST5.08-13 SUPERBENT POLE MOUNT DETAILS.dwg | Layout: ST5.09
 PLOTTED: Dec 05, 2025 05:19:39pm By: Jane Work
 XREFS: KCDC-BORDER-RHC Engineering, 3D DEAD END POLE AT SIDE OF SUPERBENT IMAGES.

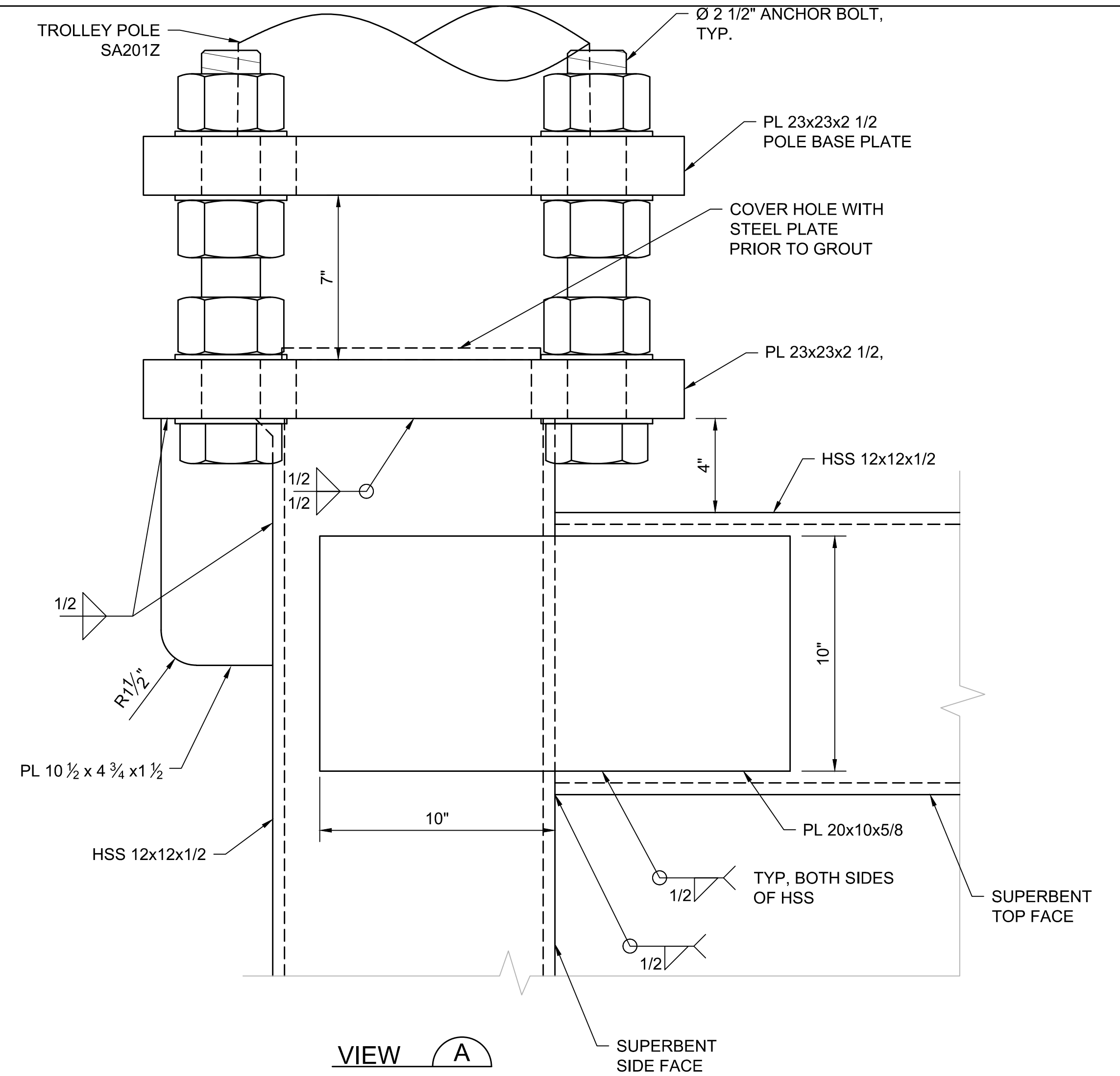
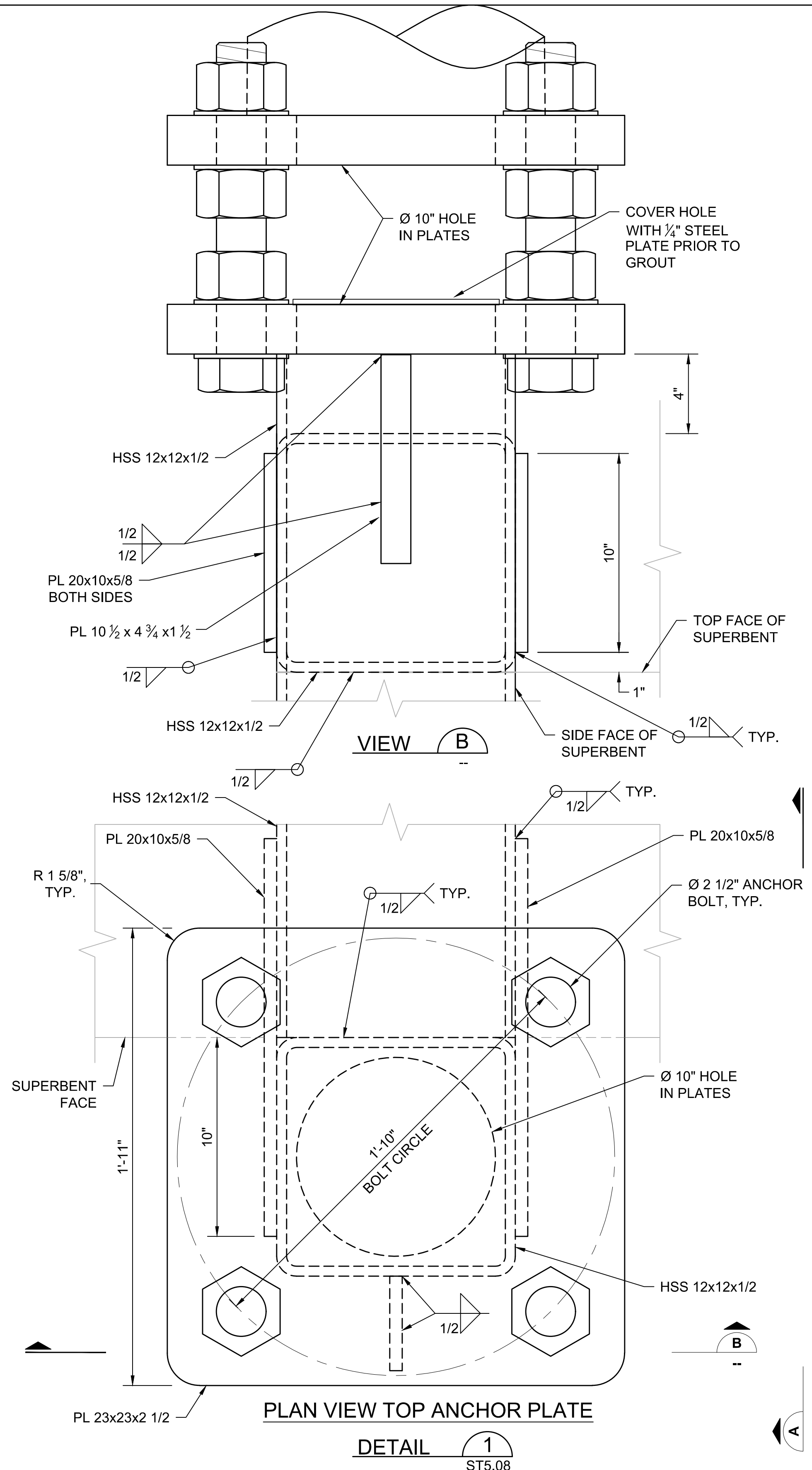

- NOTES:**
1. ALL FILLET WELD SIZE SHALL BE 1/2", UNLESS NOTED OTHERWISE.
 2. ASSEMBLE THE HSS MEMBERS AND CONNECTIONS IN SHOP, EXCEPT THE POLE WITH BASE PLATE.
 3. FIELD VERIFY THE SUPERBENT DIMENSIONS FOR HSS MEMBER LENGTH.
 4. FILL GAP BETWEEN STEEL AND CONCRETE WITH NON-SHRINK GROUT FOR A TIGHT FIT, TYP.

No.	REVISION	BY	APPD	DATE

ONE INCH

 AT FULL SCALE

RHC ENGINEERING

 WWW.RHCENGINEERING.COM
 720 3RD AVE SUITE 1400
 SEATTLE WA 98104
 PH: 206.623.5984

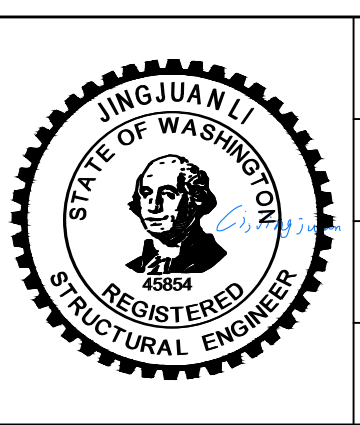

DESIGNED: J. LI	APPROVED: G. FRANCO
DRAWN: T. LOZADA	PROJECT NO: 1127254
CHECKED: G. CHEN	CONTRACT NO: -
CHECKED: -	-



METRO TRANSIT CAPITAL DIVISION
 TROLLEY OVERHEAD SYSTEM
 UNIVERSITY BRIDGE TROLLEY POLE REPLACEMENT
**SUPERBENT POLE MOUNTING
 DETAILS - 2**

DATE: DECEMBER 2, 2025
SCALE 3" = 1'-0"
DRAWING NO: ST5.09
SHEET NO. OF 18 43

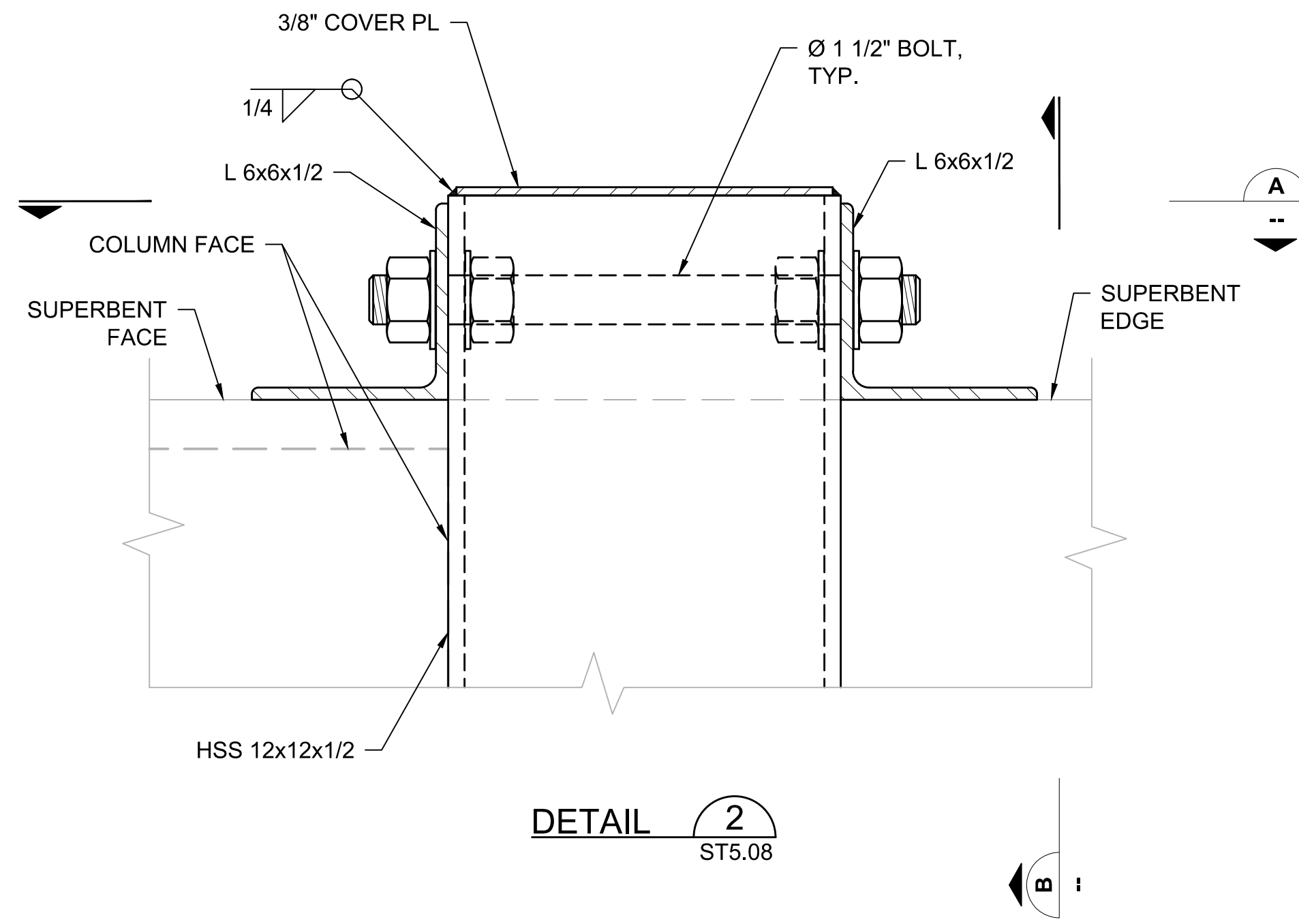

DETAIL 2
ST5.08

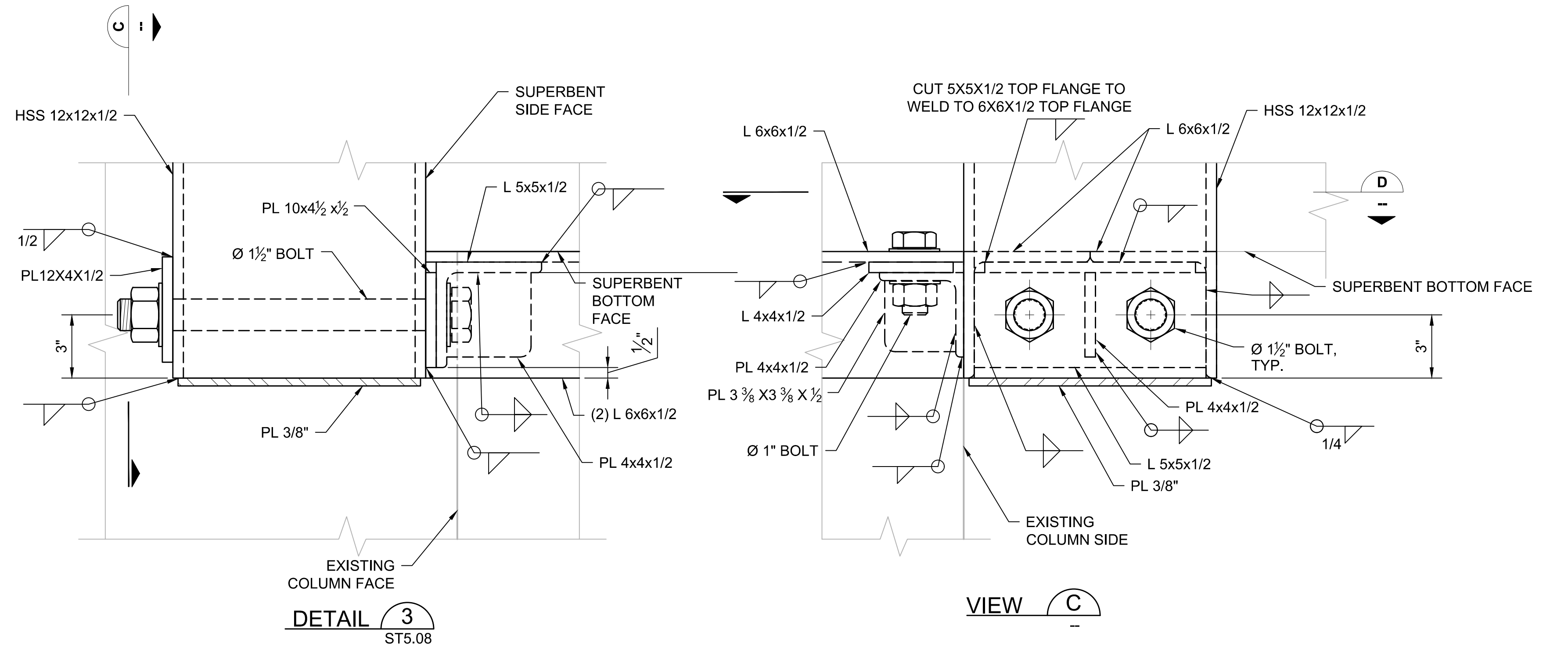

DETAIL 3
ST5.08

VIEW C

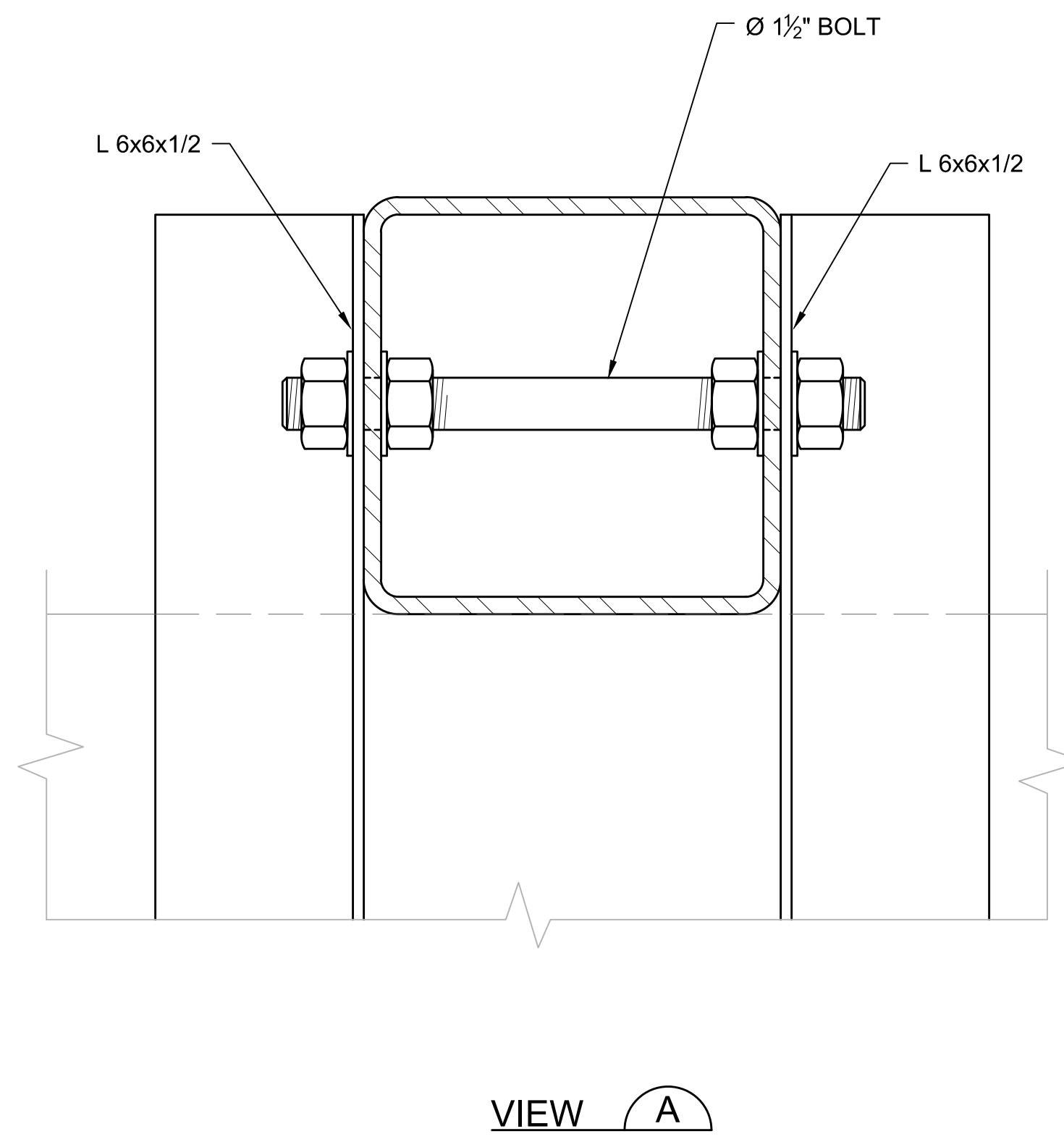

VIEW A

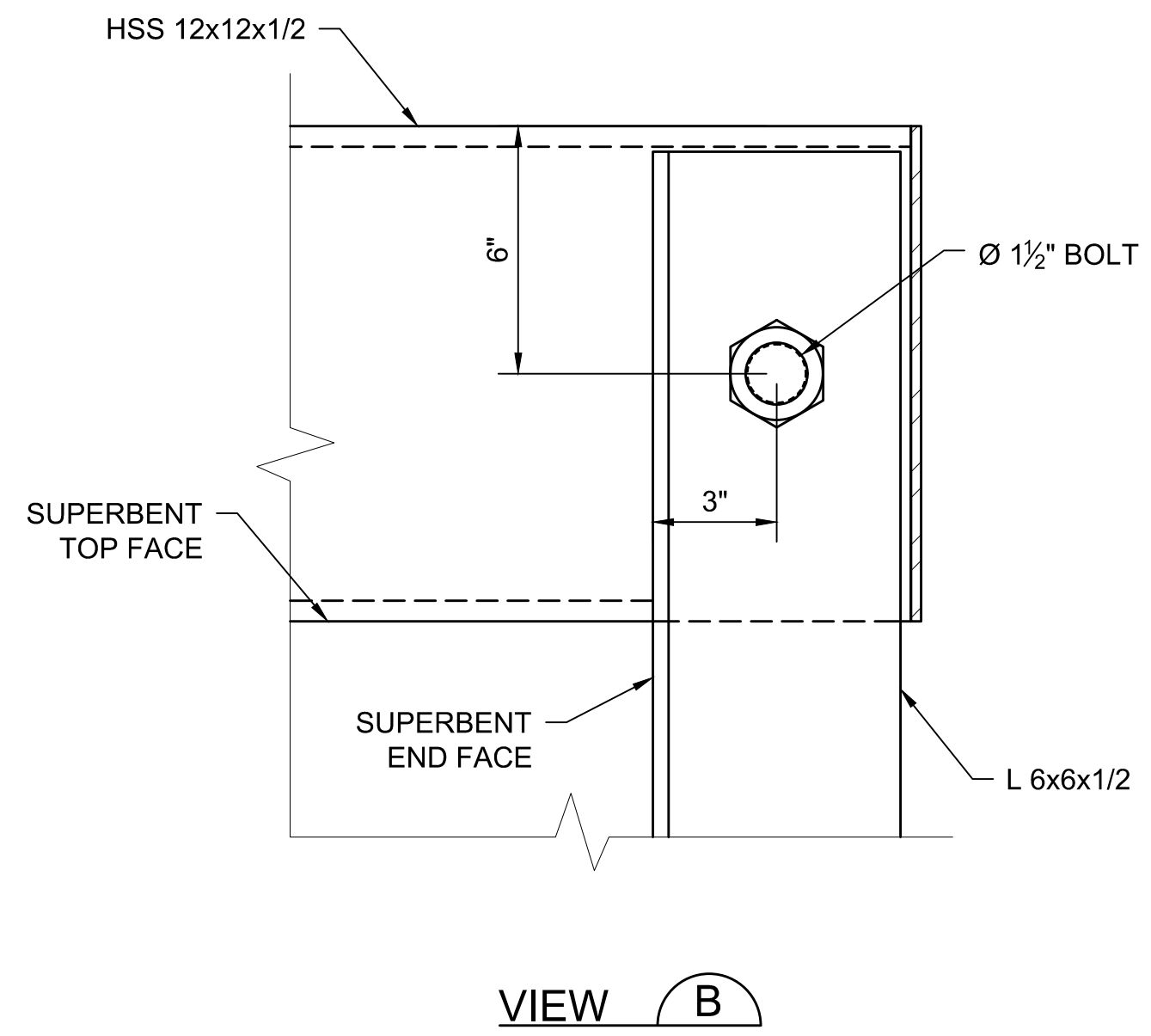

VIEW B

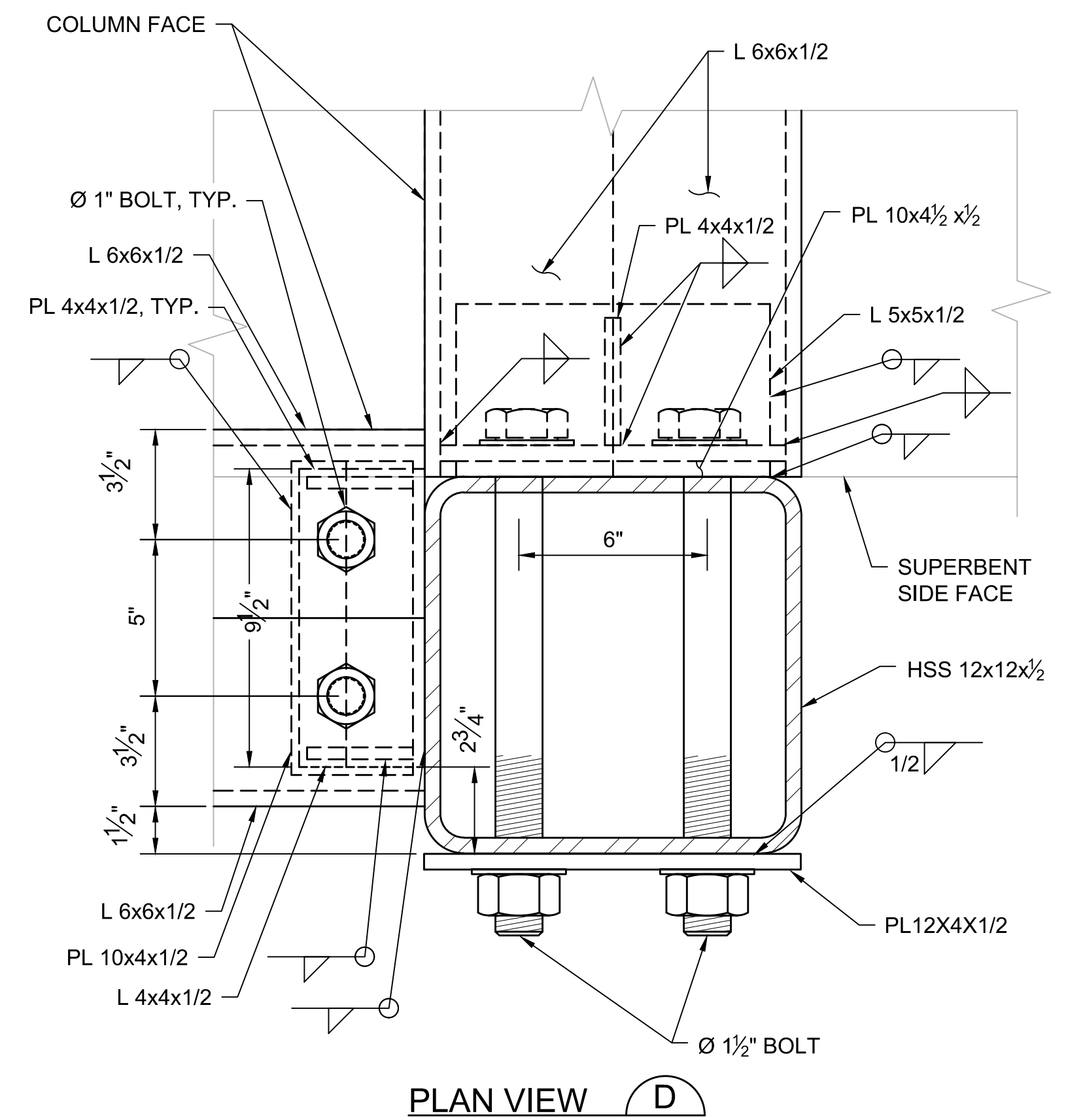

PLAN VIEW D

NOTE:
1. SEE NOTES ON SHEET ST5.08 AND ST5.09.

Z:\210127\KC University Pole Replacement\CADD\SHHEET 17-22 ST5.08-13 SUPERBENT POLE MOUNT DETAILS.dwg | Layout: ST5.10
 PLOTTED: Dec 05, 2025 05:20:15 pm By: Jane Wolk
 XREFS: KC\DC-BORDER\RHC Engineering_3D\DEAD END POLE AT SIDE OF SUPERBENT IMAGES

No.	REVISION	BY	APPD	DATE

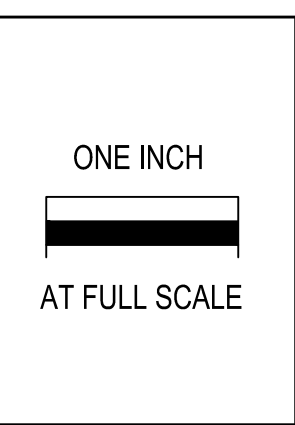

RHC ENGINEERING
 WWW.RHCENGINEERING.COM
 720 3RD AVE SUITE 1400
 SEATTLE WA 98104
 PH: 206.623.5984

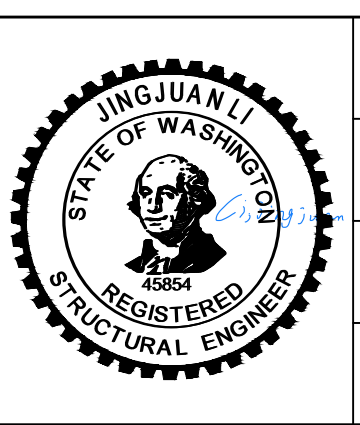

DESIGNED: J. LI	APPROVED: G. FRANCO
DRAWN: T. LOZADA	PROJECT NO: 1127254
CHECKED: G. CHEN	CONTRACT NO: -
CHECKED: -	-



METRO TRANSIT CAPITAL DIVISION
 TROLLEY OVERHEAD SYSTEM
 UNIVERSITY BRIDGE TROLLEY POLE REPLACEMENT

**SUPERBENT POLE MOUNTING
 DETAILS - 3**

DATE: DECEMBER 2, 2025
SCALE 3" = 1'-0"
DRAWING NO: ST5.10
SHEET NO. OF 19 43

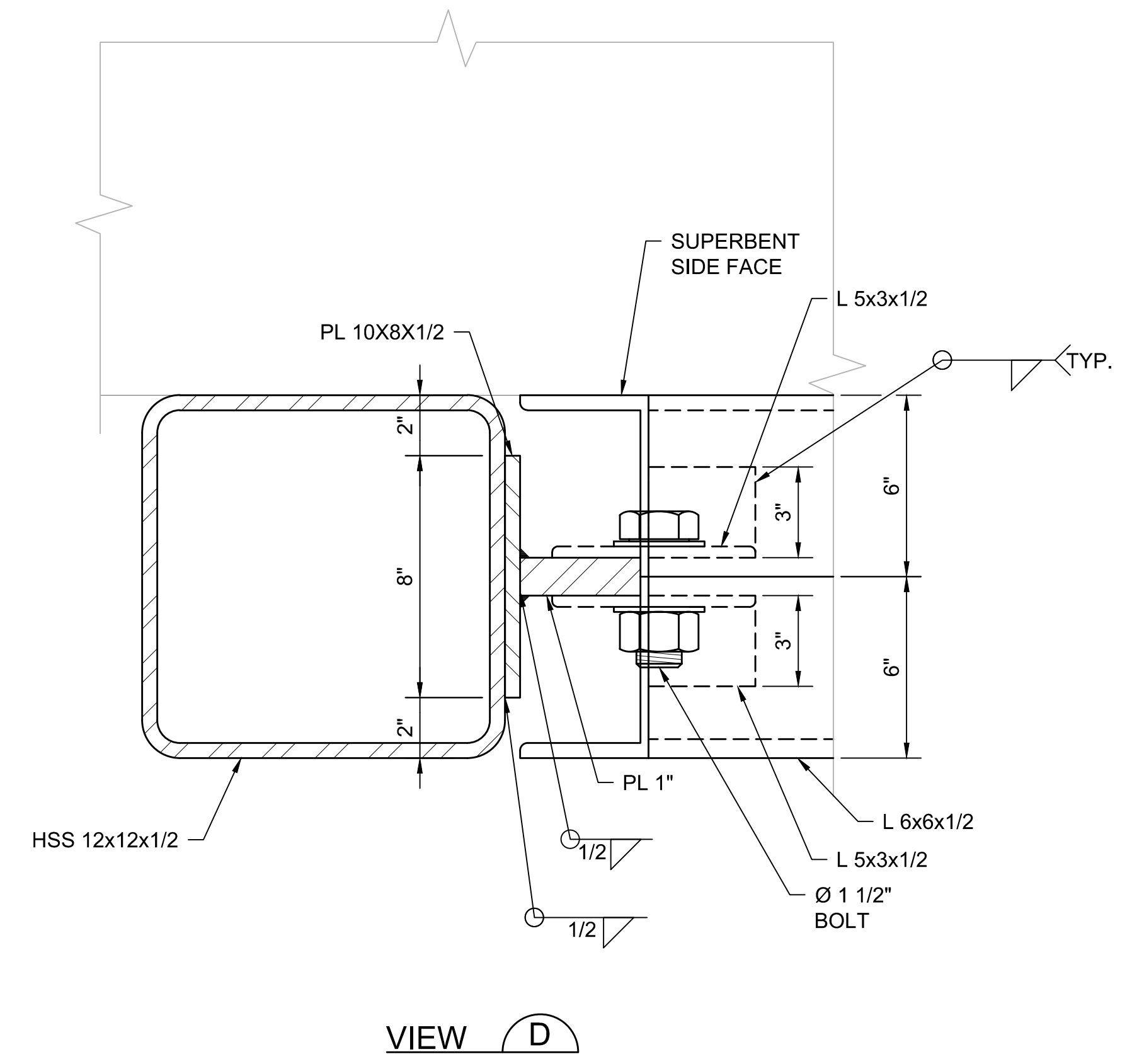
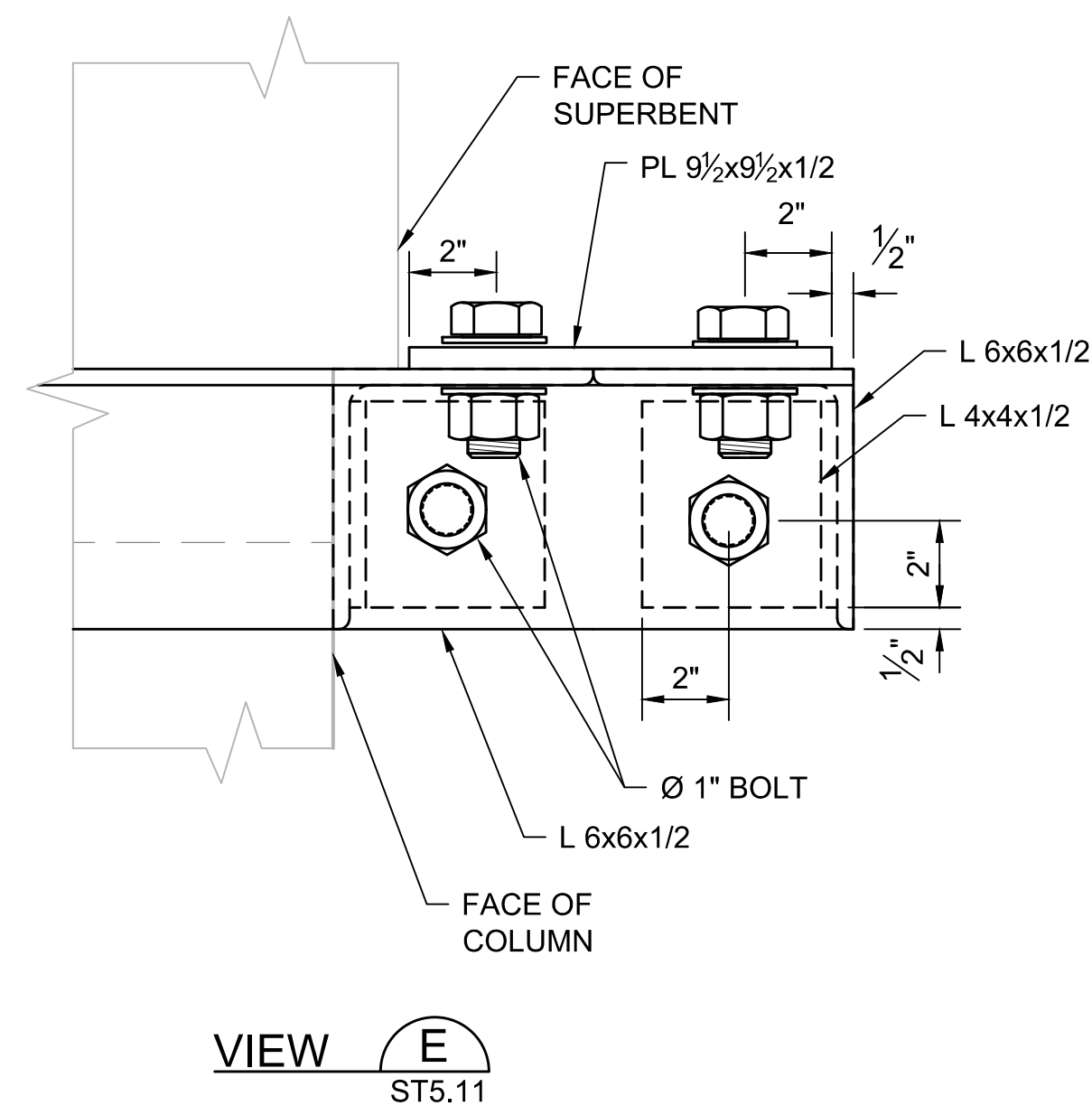
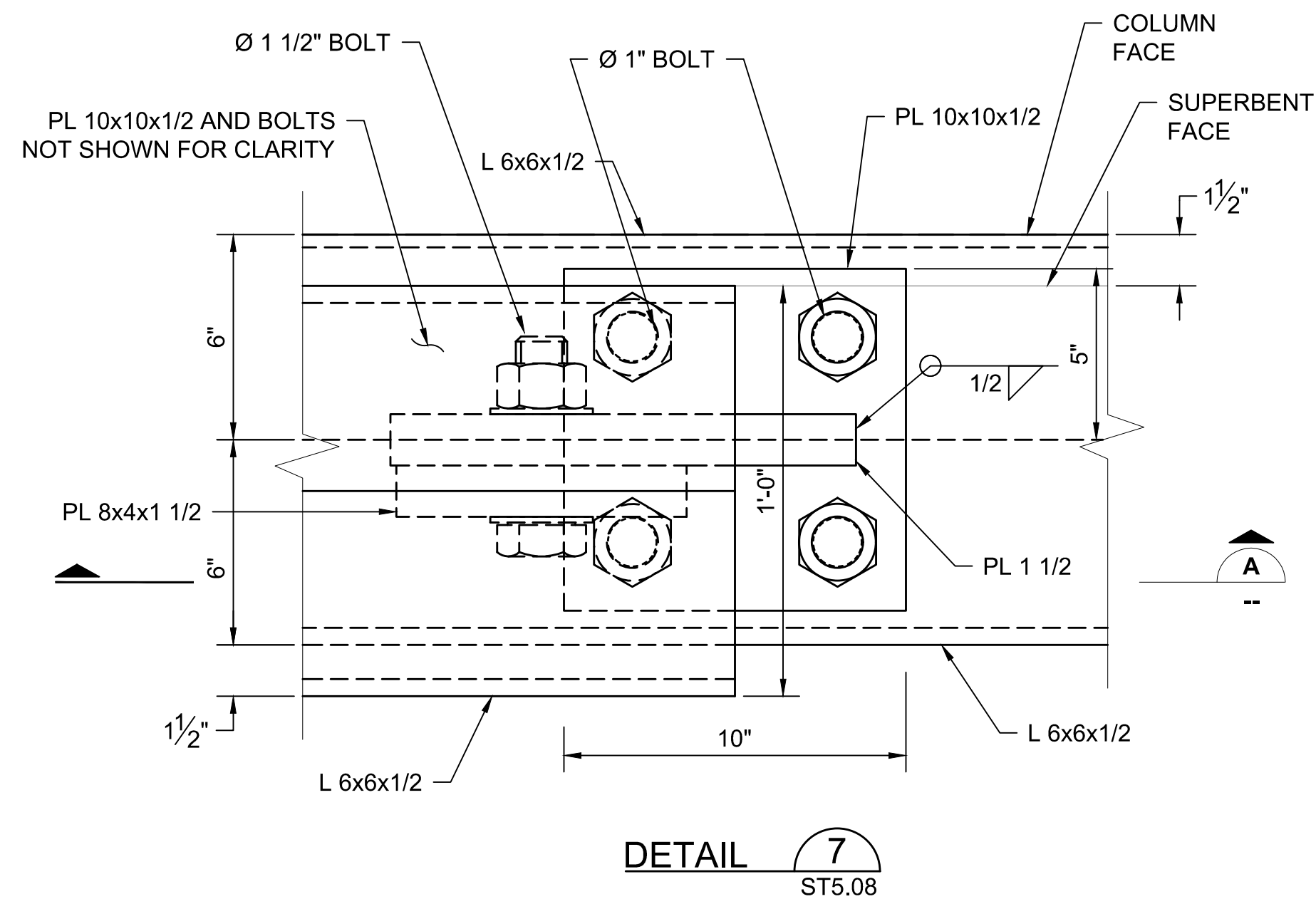
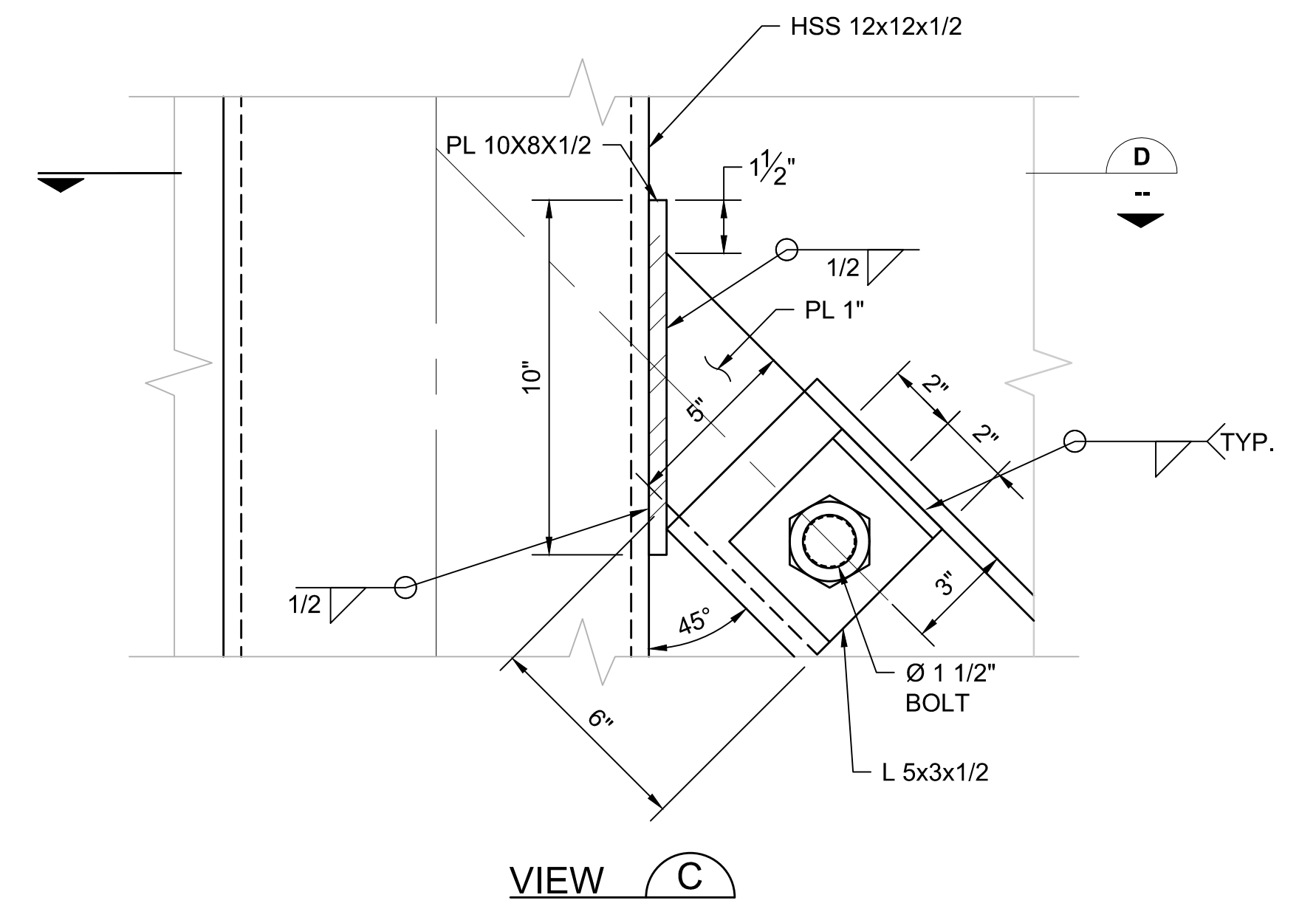
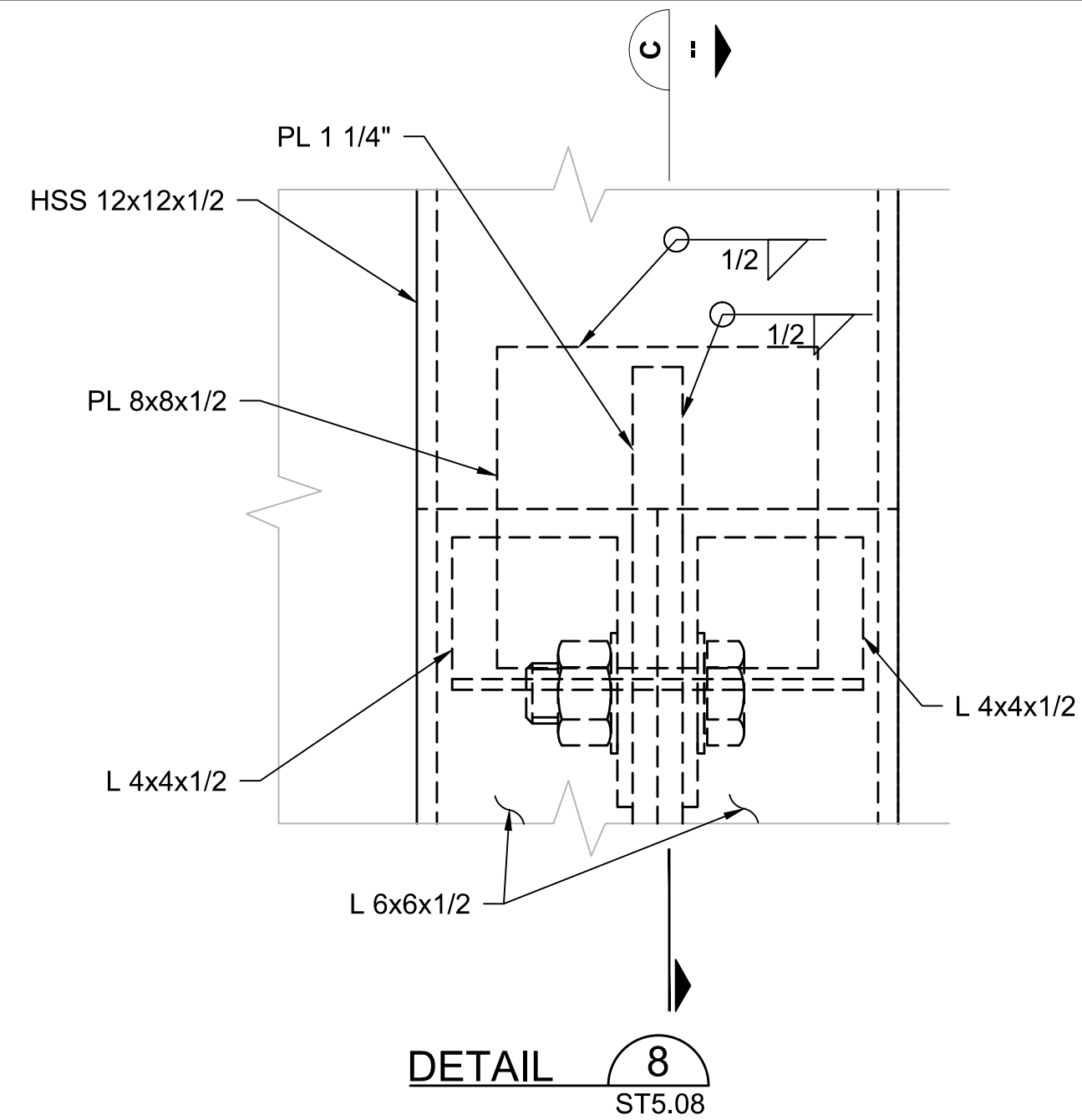
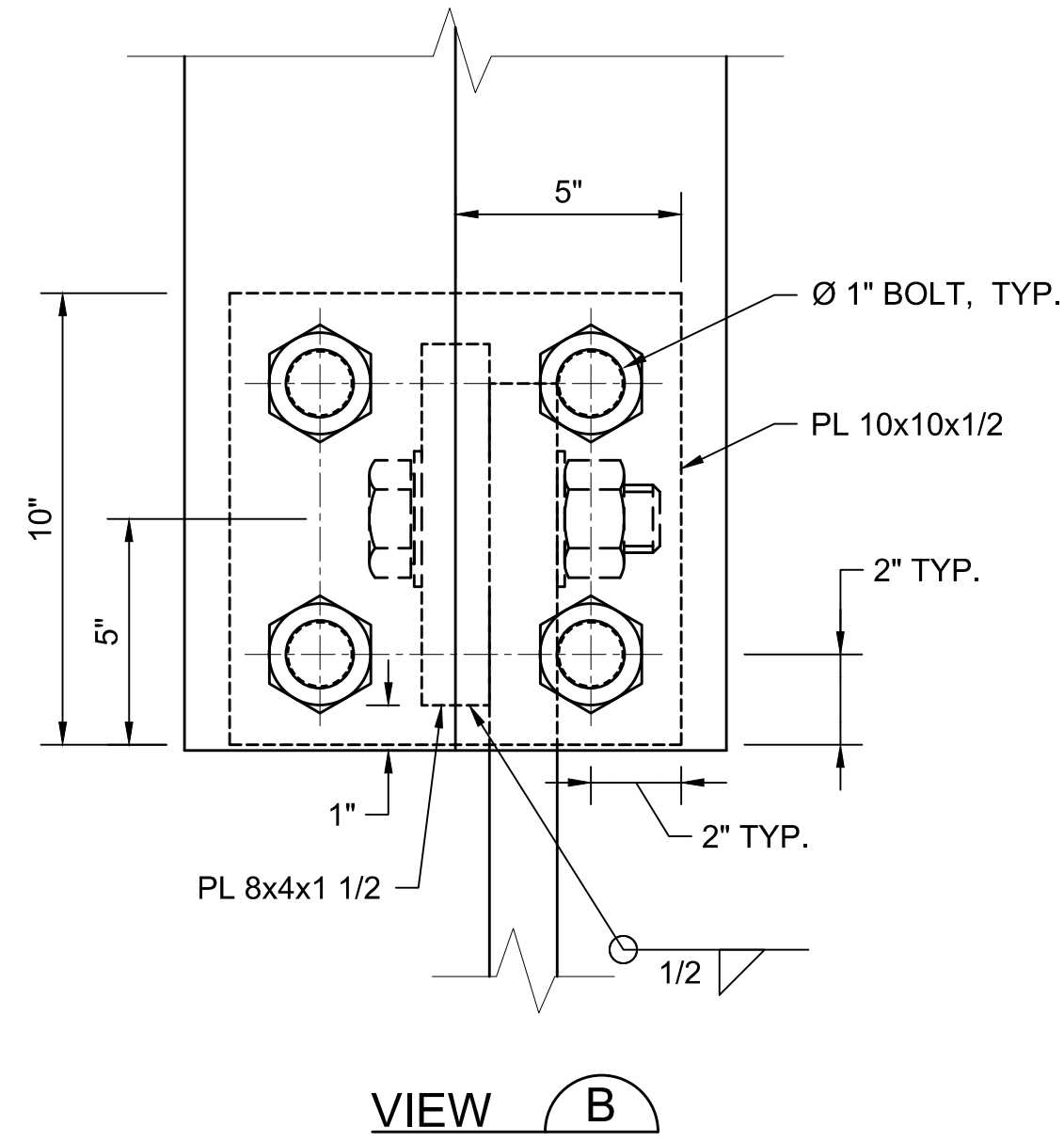
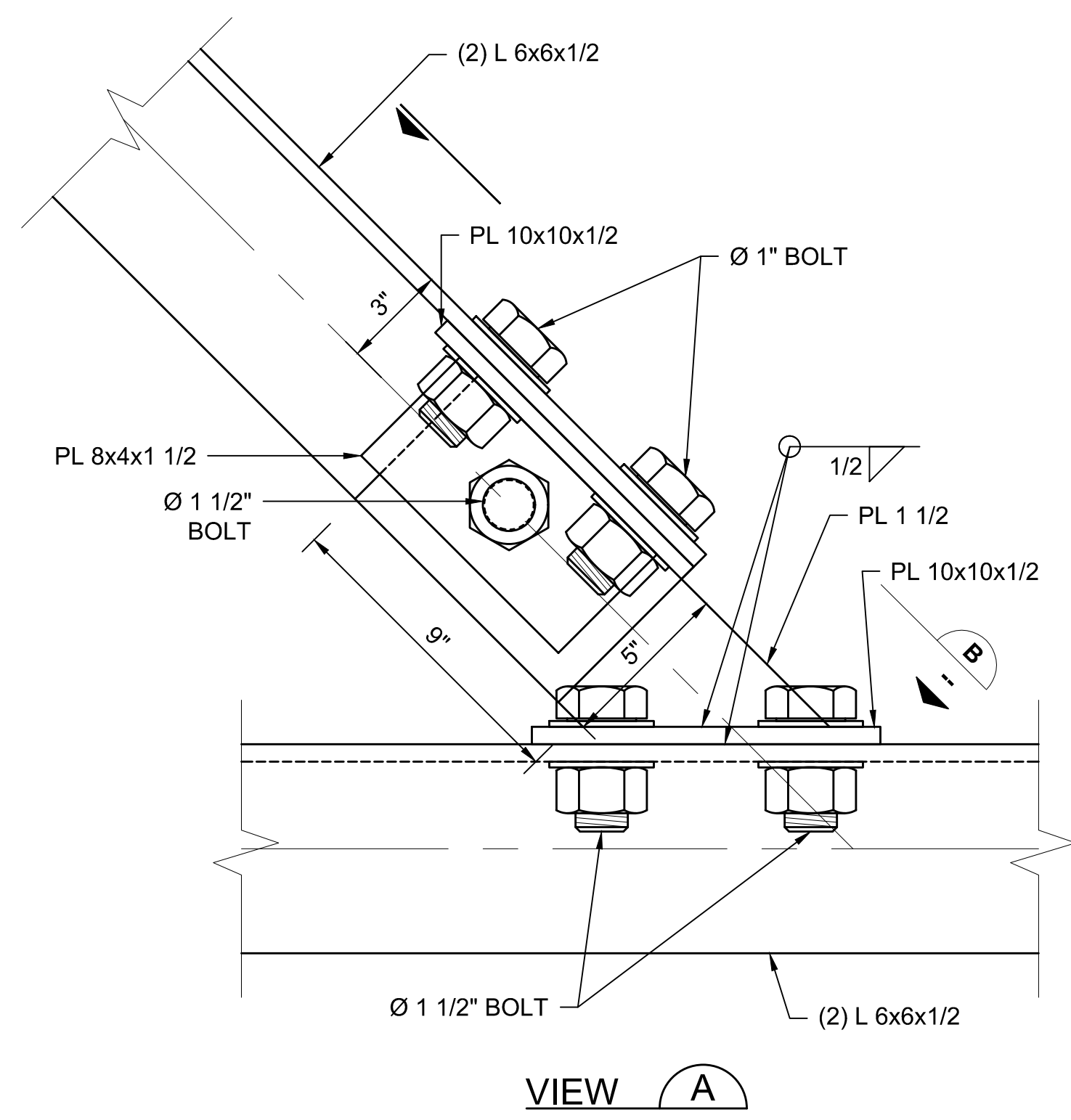

NOTE:
1. SEE NOTES ON SHEET ST5.08 AND ST5.09.

Z:\210127\KC University Pole Replacement\CADD\SHEET 17-22 ST5.08-13 SUPERBENT POLE MOUNT DETAILS.dwg | Layout: ST5.12
 PLOTTED: Dec 05, 2025 05:03:03 pm By: Jane Work
 XREFS: KC\DCBORDER\RHC Engineering_3D DEAD END POLE AT SIDE OF SUPERBENT IMAGES

No.	REVISION	BY	APP'D	DATE

ONE INCH

 AT FULL SCALE

RHC ENGINEERING
 WWW.RHCENGINEERING.COM
 720 3RD AVE SUITE 1400
 SEATTLE WA 98104
 PH: 206.623.5984

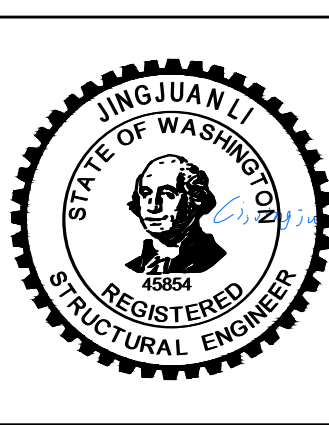

DESIGNED: J. LI	APPROVED: G. FRANCO
DRAWN: T. LOZADA	PROJECT NO: 1127254
CHECKED: G. CHEN	CONTRACT NO: -
CHECKED: -	



METRO TRANSIT CAPITAL DIVISION
 TROLLEY OVERHEAD SYSTEM
 UNIVERSITY BRIDGE TROLLEY POLE REPLACEMENT
**SUPERBENT POLE MOUNTING
 DETAILS - 5**

DATE: DECEMBER 2, 2025
SCALE 3" = 1'-0"
DRAWING NO: ST5.12
SHEET NO. OF 21 43

Z:\2025\17 KC University Pole Replacement\CADD\Sheet\17-22 ST5.08-13 SUPERBENT POLE MOUNT DETAILS.dwg | Layout: ST5.13
 PLOTTED: Dec 05, 2025 05:12:00pm By: Jane Work
 XREFS: KC-DCC-BORDER-RHC Engineering; 3D DEAD END POLE AT SIDE OF SUPERBENT IMAGES

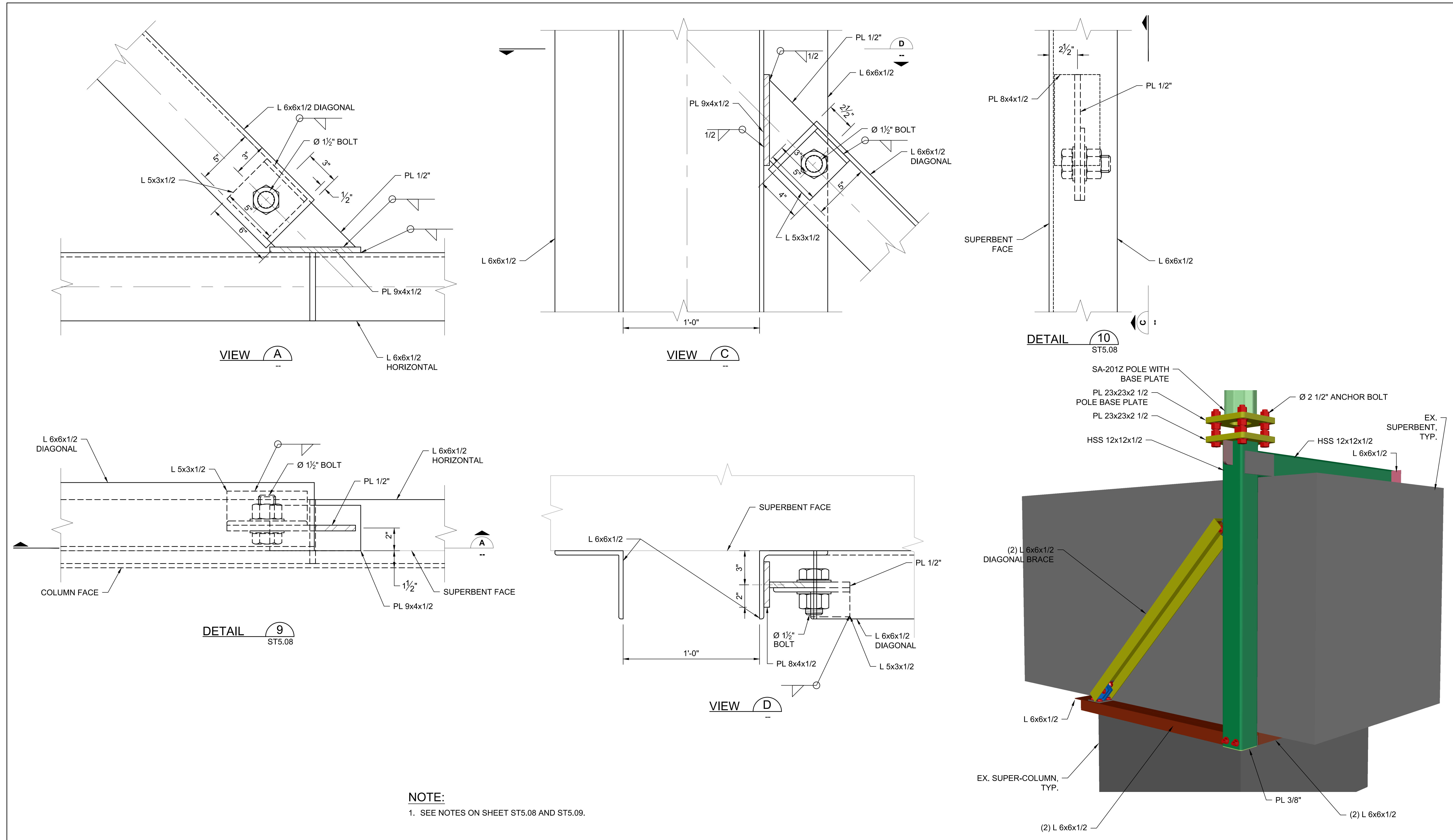

NOTE:
 1. SEE NOTES ON SHEET ST5.08 AND ST5.09.

No.	REVISION	BY	APP'D	DATE

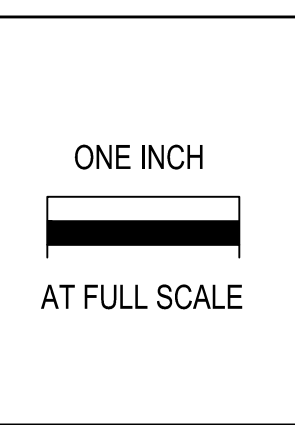

RHC ENGINEERING
 WWW.RHCENGINEERING.COM
 720 3RD AVE SUITE 1400
 SEATTLE WA 98104
 PH: 206.623.5984

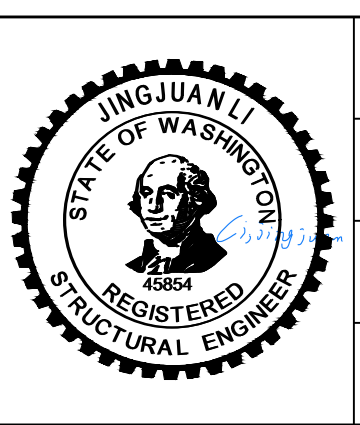

DESIGNED: J. LI	APPROVED: G. FRANCO
DRAWN: T. LOZADA	PROJECT NO: 1127254
CHECKED: G. CHEN	CONTRACT NO: -
CHECKED: -	



METRO TRANSIT CAPITAL DIVISION
 TROLLEY OVERHEAD SYSTEM
 UNIVERSITY BRIDGE TROLLEY POLE REPLACEMENT
**SUPERBENT POLE MOUNTING
 DETAILS - 6**

DATE: DECEMBER 2, 2025
SCALE 3" = 1'-0"
DRAWING NO: ST5.13
SHEET NO. OF 22 43

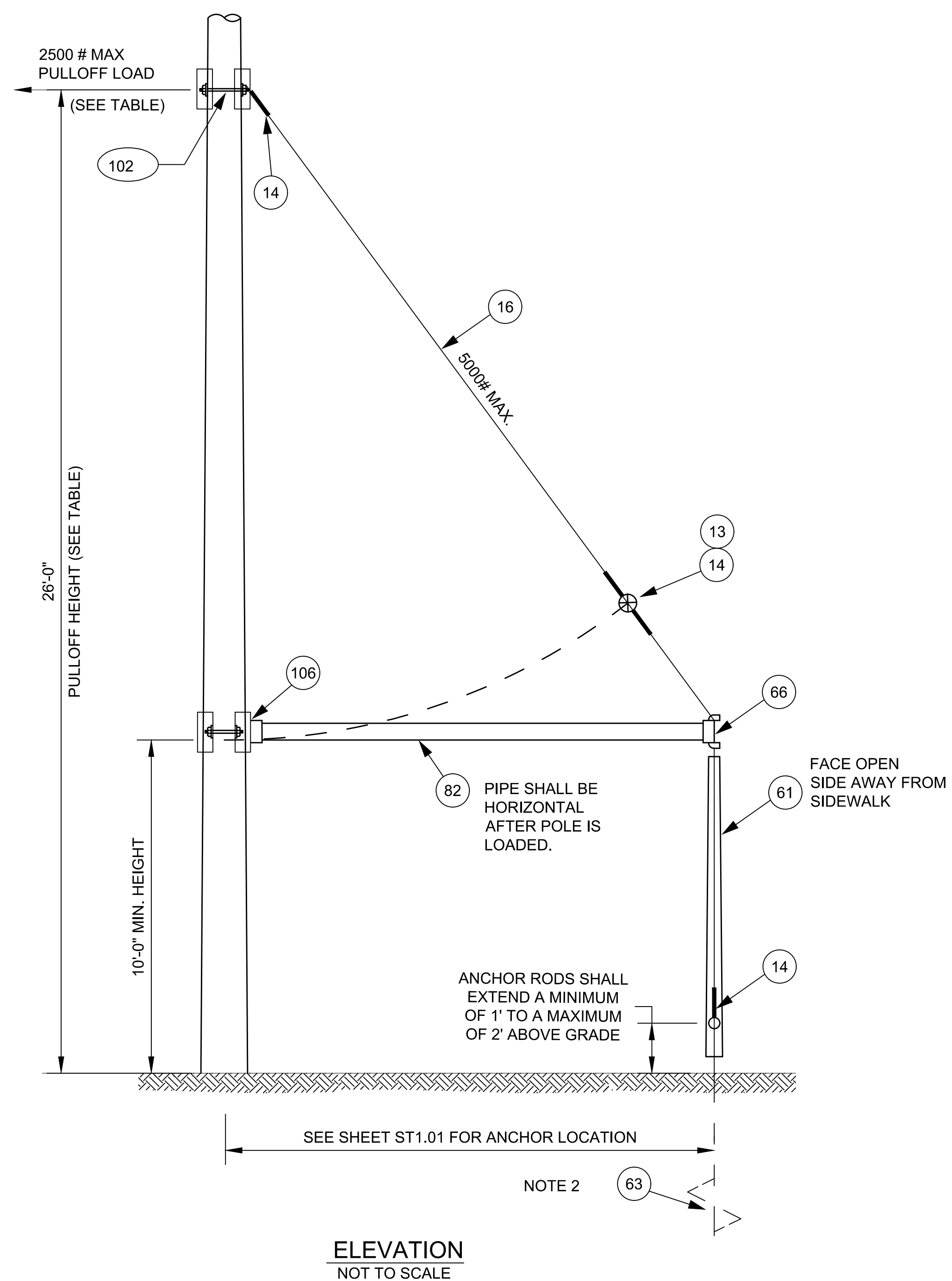

NOTES:

- SEE SHEET ST1.01 FOR LOCATIONS OF EXISTING POLES ESP1 AND ESP2 AND ANCHORS.
- SCREW ANCHORS SHALL HAVE TWO 8" HELIXES FOR GLACIAL TILL WITH A 1 1/2" HUB CAPABLE OF DEVELOPING 7000 FT-LBS MAX. WORKING TORQUE. THE ANCHOR ROD SHALL BE 1" DIAMETER WITH A TRIPLE EYE. MINIMUM INSTALLATION TORQUE FOR SCREW ANCHORS SHALL BE 3500 FT-LBS. THIS TORQUE VALUE WILL REQUIRE THE USE OF 7 SHEAR PINS FOR USE WITH THE A.B. CHANCE TORQUE INDICATOR, CAT. # C303-0044.
- CONTRACTOR SHALL REMOVE THE ANCHORS AFTER THE TEMPORARY FEEDER CABLES ARE REMOVED.

		ANCHOR DISTANCE							
		5'	6'	7'	8'	9'	10'	11'	12'
PULLOFF HEIGHT	16'	*	*	*	*	*	*	*	*
	18'	2500	*	*	*	*	*	*	*
	20'	2236	2500	*	*	*	*	*	*
	22'	1923	2236	2500	2500	*	*	*	*
	24'	1682	1970	2236	2480	2500	*	*	*
	26'	1491	1756	2004	2236	2451	2500	*	*
	28'	1338	1581	1812	2030	2236	2428	2500	*
	30'	1213	1437	1652	1857	2052	2236	2410	2500

* = MAXIMUM LOAD OF 2500 # APPLIES.

MATERIAL LIST **				
ITEM #	QTY	DESCRIPTION	MANUFACTURER	CAT. NO.
13	1	GUY STRAIN INSUL	PORCELAIN PRODUCTS CO.	506
14	4	GUY GRIP DEADEND	PREFORMED	CDE-3115
16	VARIES	GUY STRAND	COPPERWELD	16M
61	1	GUY GUARD, 8 FT, FOR USE ON 3/16" TO 1/2" STRAND	PREFORMED	PG 5518
63	1	POWER INSTALLED SCREW ANCHOR	CHANCE	C102-1260
66	1	END FITTING, 2 1/2" PIPE	COOPER POWER SYSTEM	DG5G1
82	VARIES	2 1/2" DIAMETER ASTM A53 GRADE B STANDARD WEIGHT GALVANIZED STEEL PIPE		
102	VARIES	FORGED THREE-PIECE ADJUSTABLE POLE BAND	METRO STANDARD	SA-102
106	4	POLE COLLAR WITH 2 1/2" PIPE END CAP	METRO STANDARD	SA-102

** OR APPROVED EQUIVALENT ALTERNATIVES

7/31/2023 KCI University Pole Replacement/CADD SHEET 23 ST5.14 Steel Pole Sidewalk Guy.dwg | Layout: SIDEWALK GUY
 PLOTTED: Dec 14, 2025, 09:15:36 am, By: Jane Work
 XREFS: KCTDC-ORDER-RHC Engineering

No.	REVISION	BY	APP'D	DATE

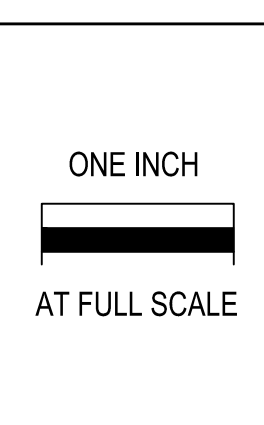

RHC ENGINEERING
 WWW.RHCENGINEERING.COM
 720 3RD AVE SUITE 1400
 SEATTLE WA 98104
 PH: 206.623.5984

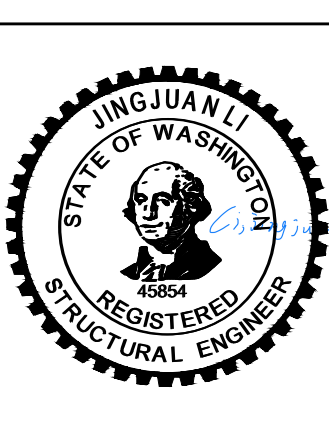

DESIGNED: J. LI	APPROVED: G. FRANCO
DRAWN: T. LOZADA	PROJECT NO: 1127254
CHECKED: G. CHEN	CONTRACT NO: -
CHECKED: -	



METRO TRANSIT CAPITAL DIVISION
 TROLLEY OVERHEAD SYSTEM
 UNIVERSITY BRIDGE TROLLEY POLE REPLACEMENT

**STEEL POLE
 SIDEWALK GUY DETAILS**

DATE: DECEMBER 2, 2025
DRAWING NO: ST5.14
SHEET NO. OF 23 43

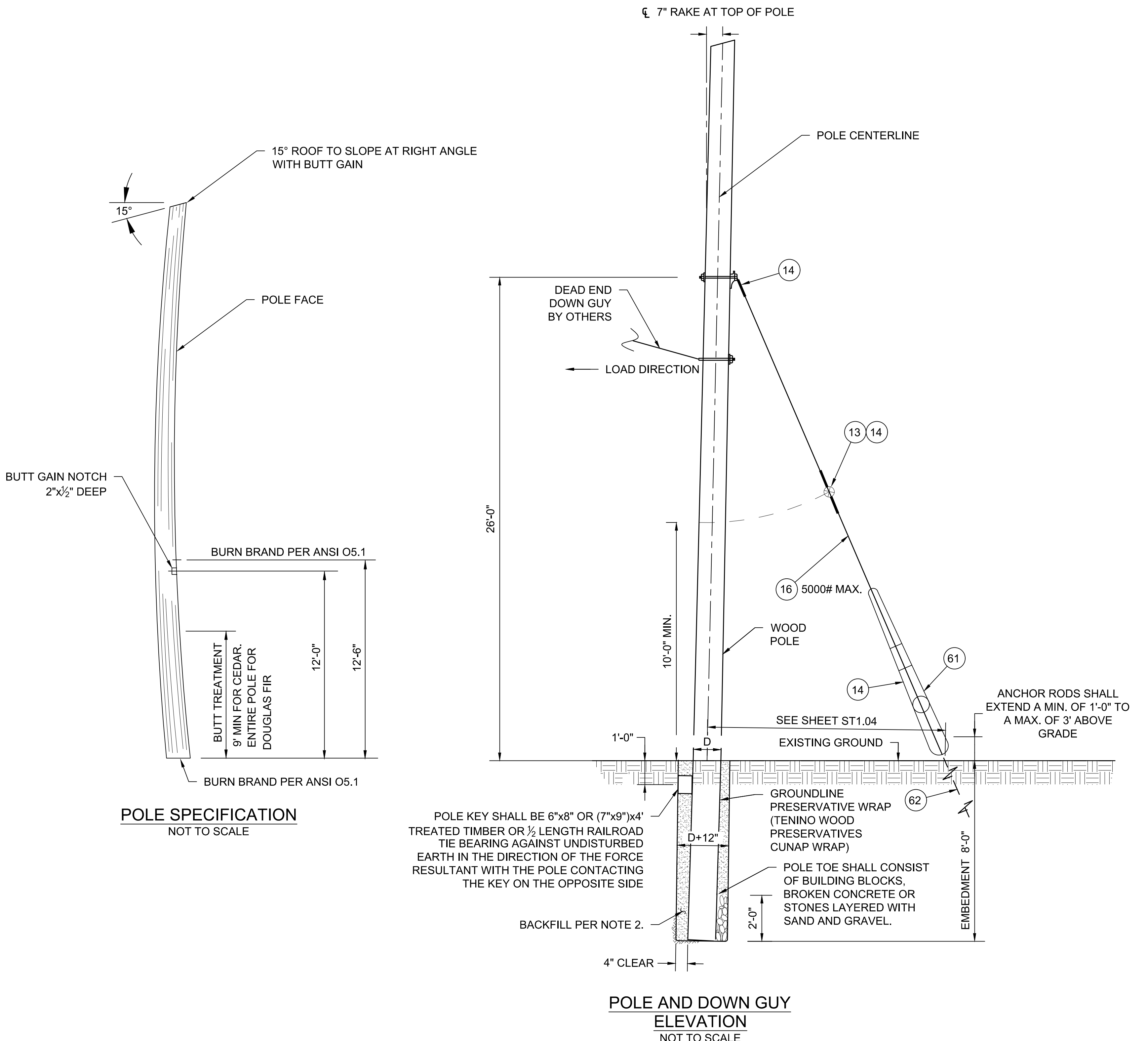

NOTES:

- SEE SHEET ST1.04 FOR LOCATIONS OF NEW TEMPORARY WOOD POLES AND ANCHORS.
- SCREW ANCHORS SHALL HAVE TWO 8" HELIXES FOR GLACIAL TILL WITH A 1 1/2" HUB CAPABLE OF DEVELOPING 7000 FT-LBS MAX. WORKING TORQUE. THE ANCHOR ROD SHALL BE 1" DIAMETER WITH A TRIPLE EYE. MINIMUM INSTALLATION TORQUE FOR SCREW ANCHORS SHALL BE 3500 FT-LBS. THIS TORQUE VALUE WILL REQUIRE THE USE OF 7 SHEAR PINS FOR USE WITH THE A.B. CHANCE TORQUE INDICATOR, CAT. # C303-0044.
- POLE SHALL BE 40'-0" CLASS H2, WESTERN RED CEDAR OR DOUGLAS FIR, PER ANSI O5.1-LATEST EDITION.
- METAL TAGS AND NAILS FOR BURN BRAND ARE NOT ALLOWED.
- WOOD POLE WILL BE SUPPLIED BY METRO. CONTRACTOR SHALL NOT DAMAGE THE WOOD POLES DURING CONSTRUCTION AND SHALL RETURN THE UNDAMAGED WOOD POLE TO KING COUNTY AFTER THE TEMPORARY FEEDER CABLES ARE REMOVED. CONTRACTOR SHALL REMOVE THE ANCHORS WHEN REMOVE THE WOOD POLE.

		ANCHOR DISTANCE							
		5'	6'	7'	8'	9'	10'	11'	12'
PULLOFF HEIGHT	16'	*	*	*	*	*	*	*	*
	18'	2500	*	*	*	*	*	*	*
	20'	2236	2500	*	*	*	*	*	*
	22'	1923	2236	2500	2500	*	*	*	*
	24'	1682	1970	2236	2480	2500	*	*	*
	26'	1491	1756	2004	2236	2451	2500	*	*
	28'	1338	1581	1812	2030	2236	2428	2500	*
	30'	1213	1437	1652	1857	2052	2236	2410	2500

* = MAXIMUM LOAD OF 2500 # APPLIES.

MATERIAL LIST **				
ITEM #	QTY	DESCRIPTION	MANUFACTURER	CAT. NO.
13	1	GUY STRAIN INSUL	PORCELAIN PRODUCTS CO.	506
14	4	GUY GRIP DEADEND	PREFORMED	CDE-3115
16	VARIABLES	GUY STRAND	COPPERWELD	16M
61	1	GUY GUARD, 8 FT, FOR USE ON 3/16" TO 1/2" STRAND	PREFORMED	PG 5518
62	1	POWER INSTALLED SCREW ANCHOR	CHANCE	C102-1219

** OR APPROVED EQUIVALENT ALTERNATIVES

7/31/2025 King County Metro Replacement/CADD/SHEET 24 ST5.15 Wood Pole Down Guy.dwg | Layout: DOWN GUY
 PLOTTED: Dec 11, 2025, 09:16:55am, By: Jane Work
 XREFS: KCTDC-ORDERER-RHC Engineering

No.	REVISION	BY	APP'D	DATE

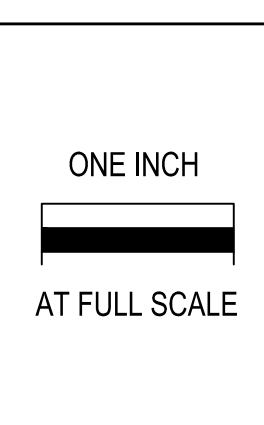

RHC ENGINEERING
 WWW.RHCENGINEERING.COM
 720 3RD AVE SUITE 1400
 SEATTLE WA 98104
 PH: 206.623.5984

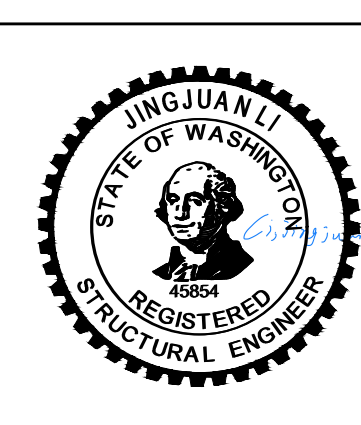

DESIGNED: J. LI	APPROVED: G. FRANCO
DRAWN: T. LOZADA	PROJECT NO: 1127254
CHECKED: G. CHEN	CONTRACT NO: -



METRO TRANSIT CAPITAL DIVISION
 TROLLEY OVERHEAD SYSTEM
 UNIVERSITY BRIDGE TROLLEY POLE REPLACEMENT

**WOOD POLE
 DOWN GUY DETAILS**

DATE: DECEMBER 2, 2025
DRAWING NO: ST5.15
SHEET NO. OF 24 43

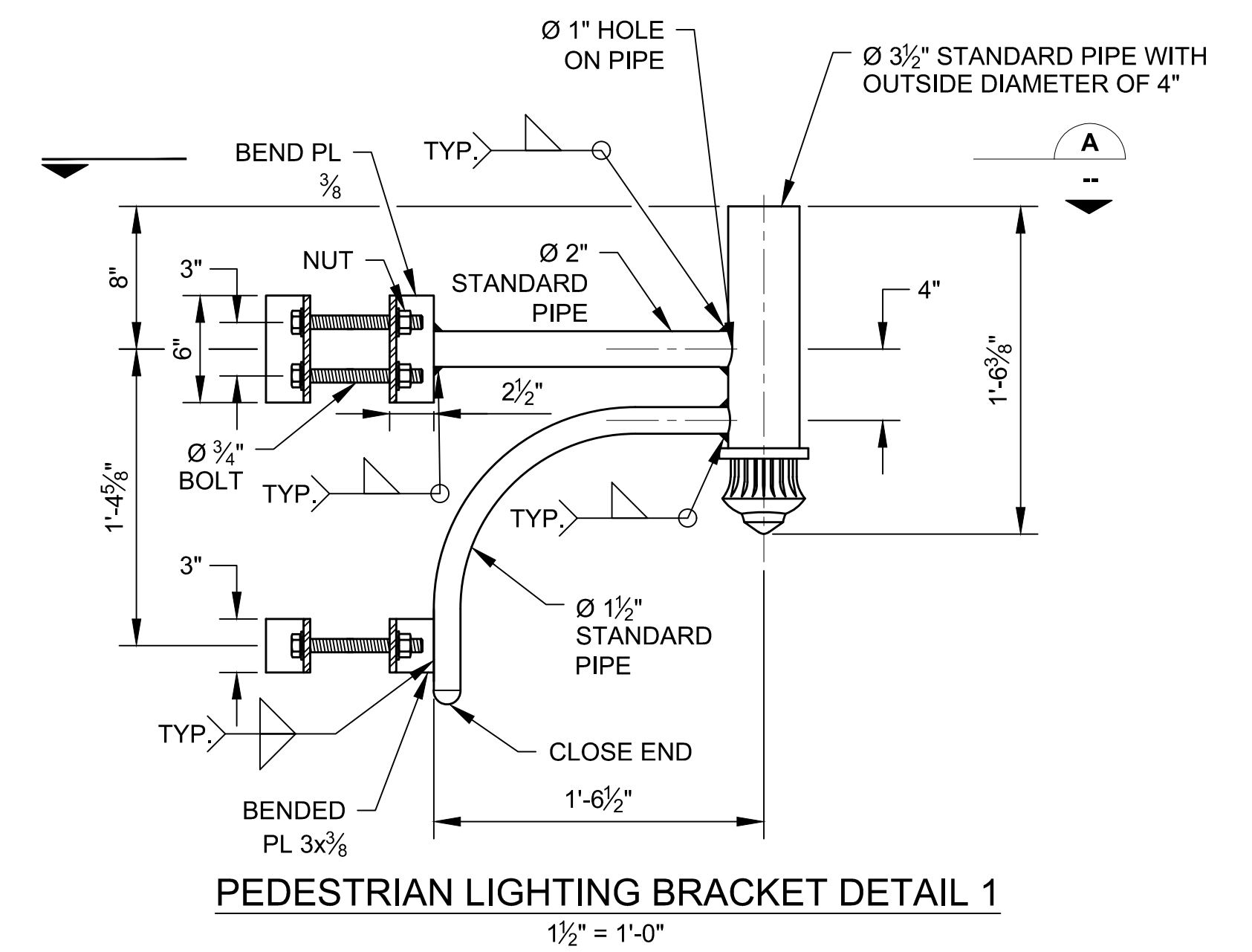
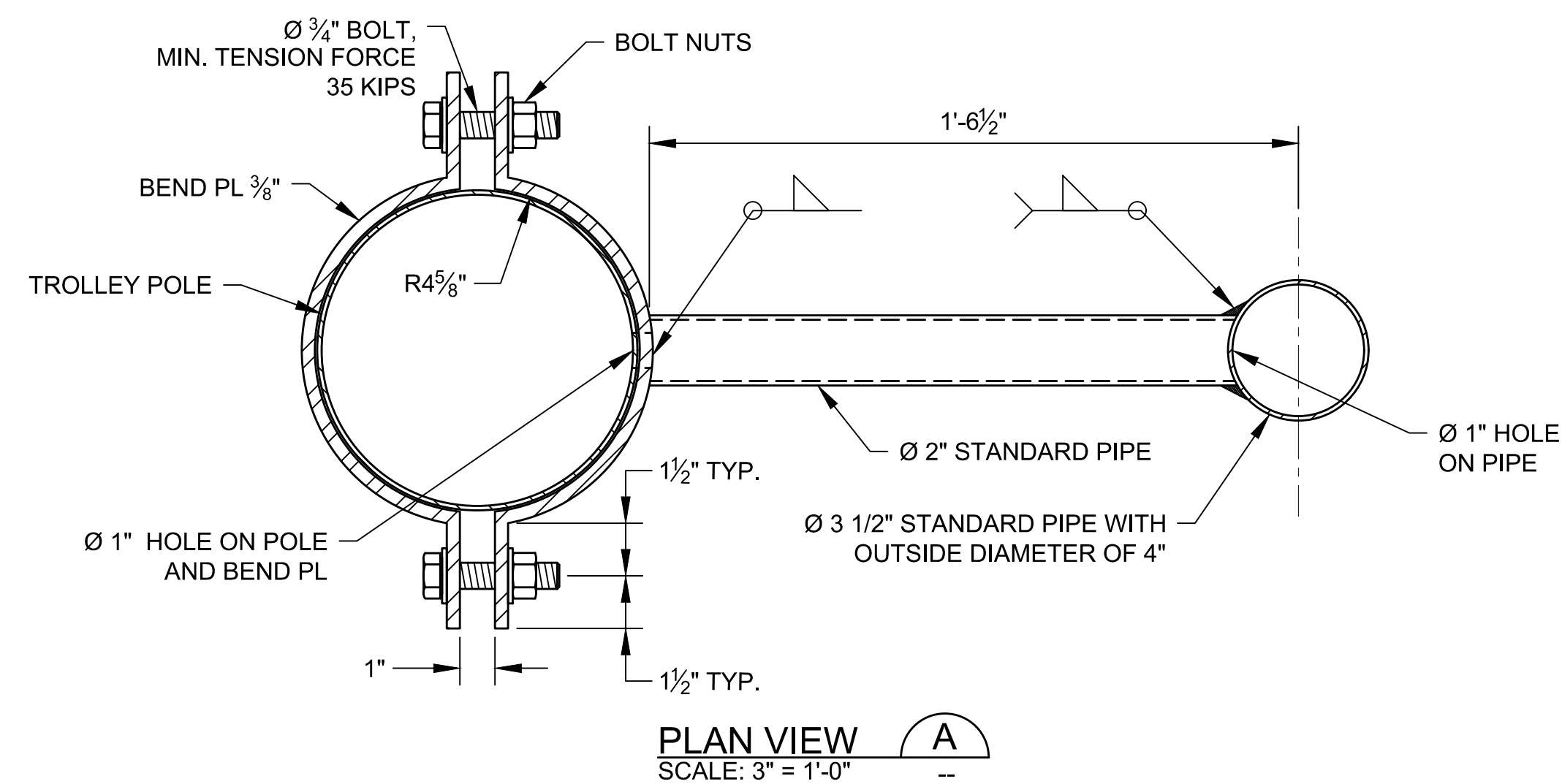
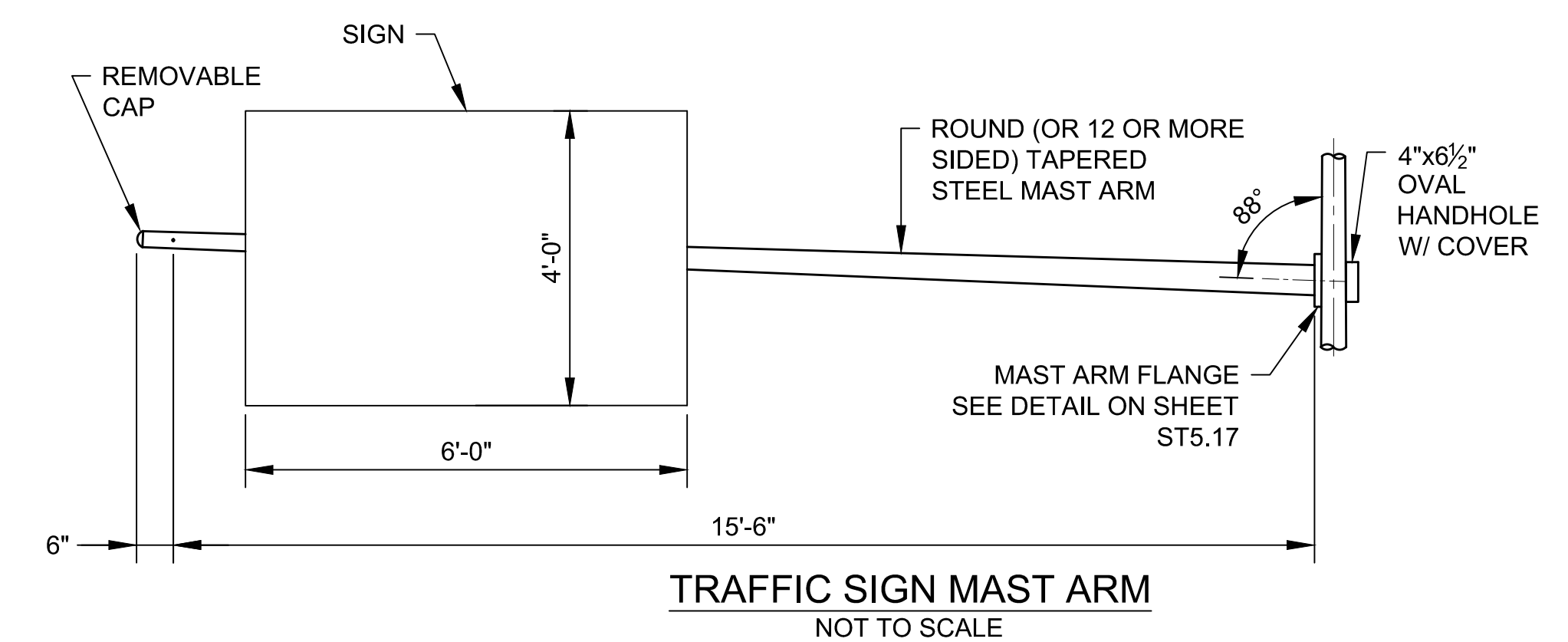
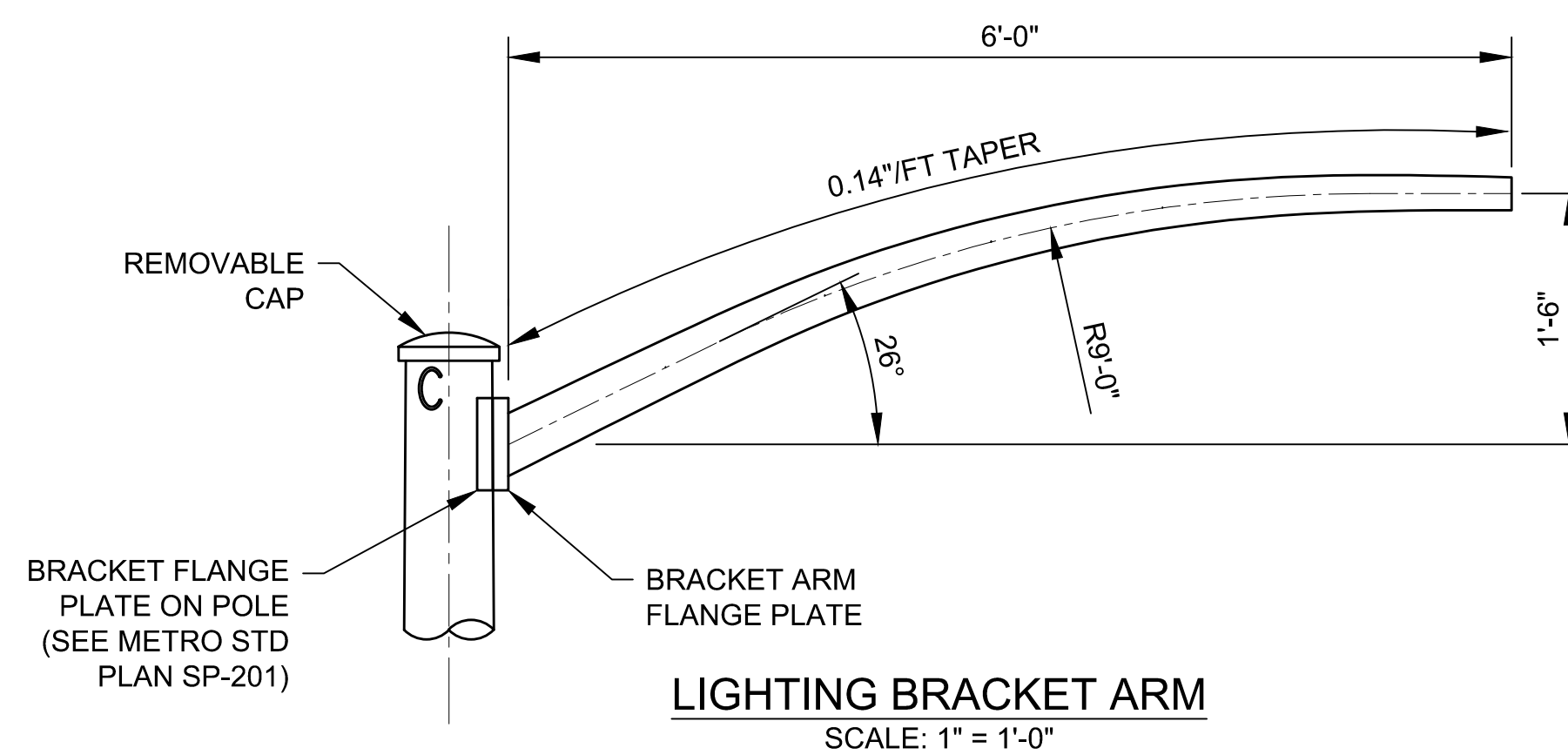
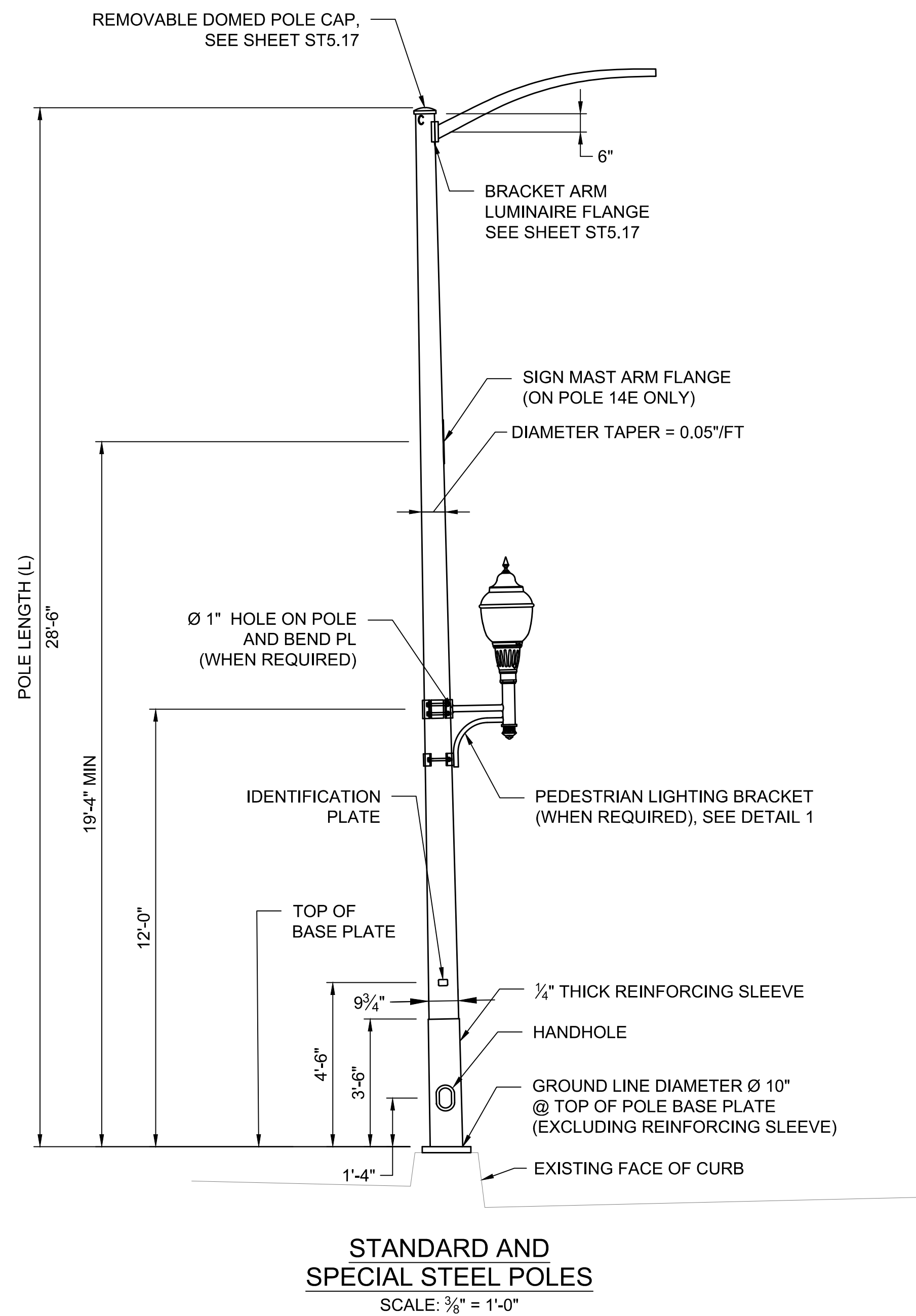

NOTES:

1. FIELD VERIFY ALL EXISTING DIMENSIONS AND CONDITIONS, NOTIFY ENGINEER IF THERE IS ANY DISCREPANCY BETWEEN PLAN AND ACTUAL DIMENSIONS.
2. REFER TO METRO STANDARD PLAN SP-201 FOR POLE MATERIAL REQUIREMENTS AND ATTACHMENT DETAILS.

Z:\210127\KC University Pole Replacement\CADD\SHEET 25 ST5.16 Pole Specifications-1.dwg | Layout: ST5.16
PLOTTED: Dec 05, 2025 05:52:23pm By: Jane Work
XREFS: KCDC-BORDER-RHC Engineering IMAGES

No.	REVISION	BY	APP'D	DATE

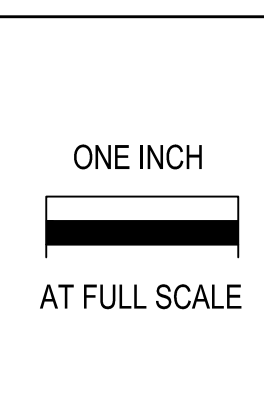

RHC ENGINEERING
WWW.RHCENGINEERING.COM
720 3RD AVE SUITE 1400
SEATTLE WA 98104
PH: 206.623.5984

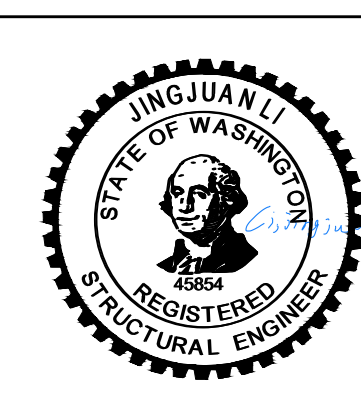

DESIGNED: J. LI	APPROVED: G. FRANCO
DRAWN: T. LOZADA	PROJECT NO: 1127254
CHECKED: G. CHEN	CONTRACT NO: -
CHECKED: -	



METRO TRANSIT CAPITAL DIVISION
TROLLEY OVERHEAD SYSTEM
UNIVERSITY BRIDGE TROLLEY POLE REPLACEMENT

POLE SPECIFICATIONS - 1

DATE: DECEMBER 2, 2025
DRAWING NO: ST5.16
SHEET NO. OF 25 43

POLE CAP NOTES:

1. CAST POLE TOP CAP HELD IN PLACE W/ (3) 3/8"-16 UNC STAINLESS STEEL SET SCREWS.
2. CAP WILL BE SEIZED TO FIT OVER ALLADIN TOP PLATE WHEN REQUIRED.
3. STEEL SHALL BE 0.1" MINIMUM THICKNESS

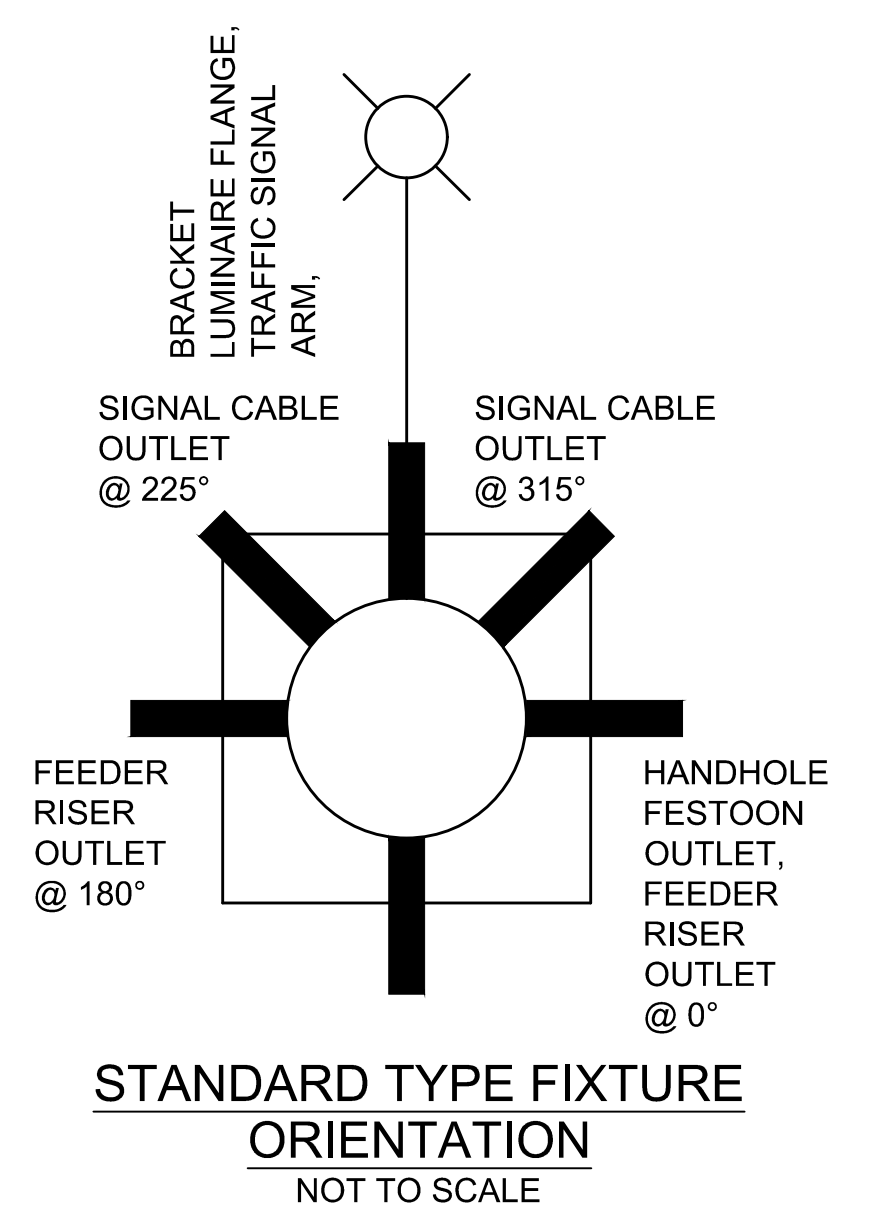
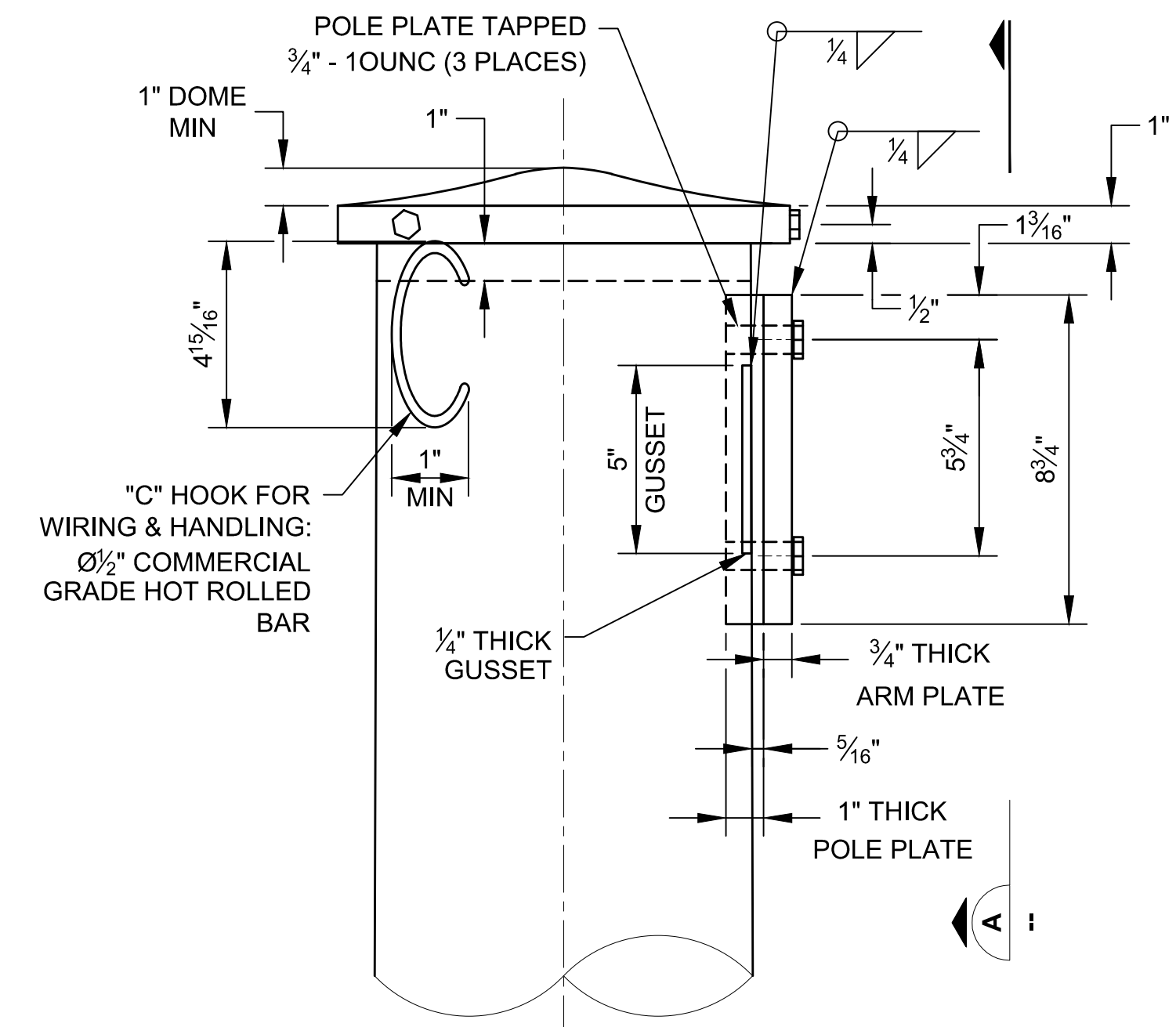
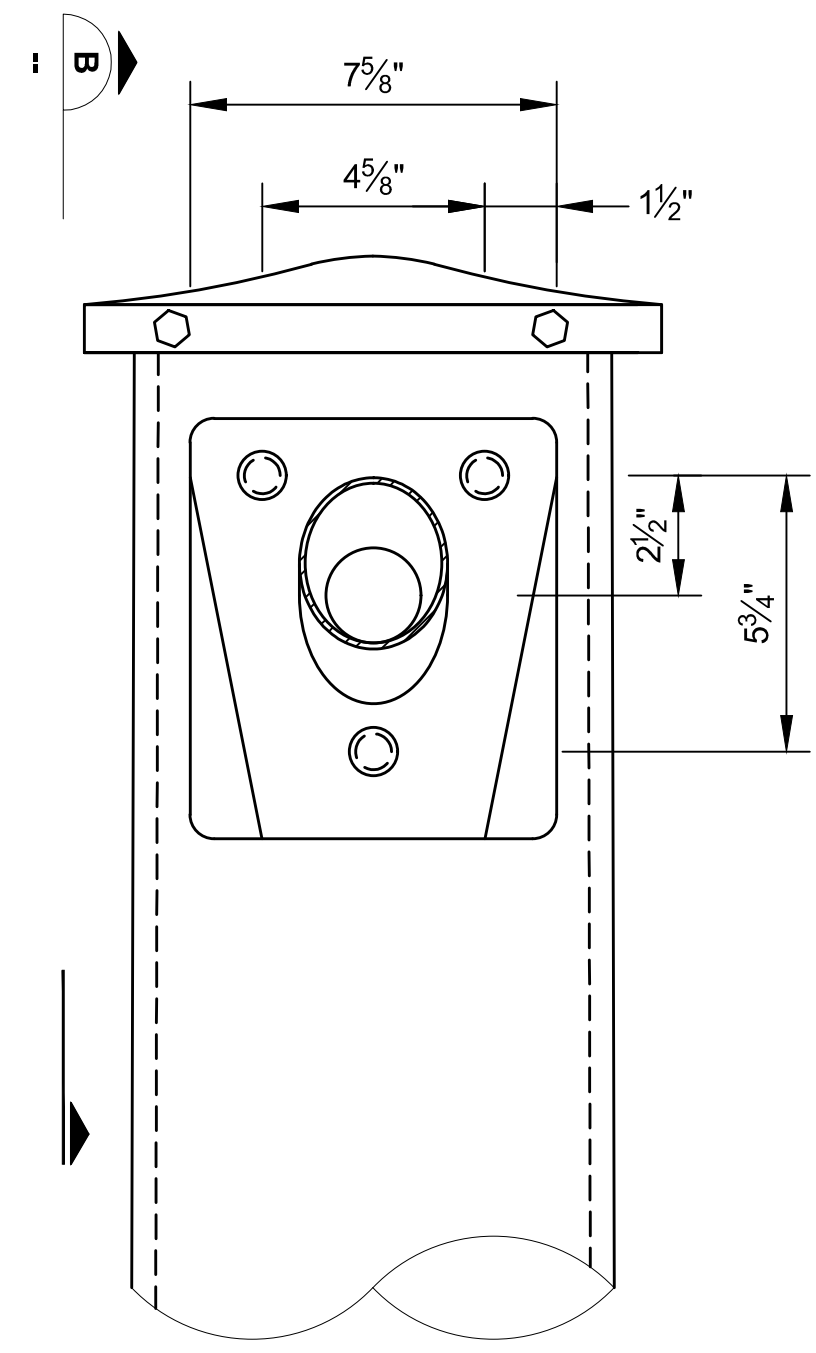

BRACKET ARM LUMINAIRE FLANGE AND POLE TOP DETAIL
SCALE: 3" = 1'-0"

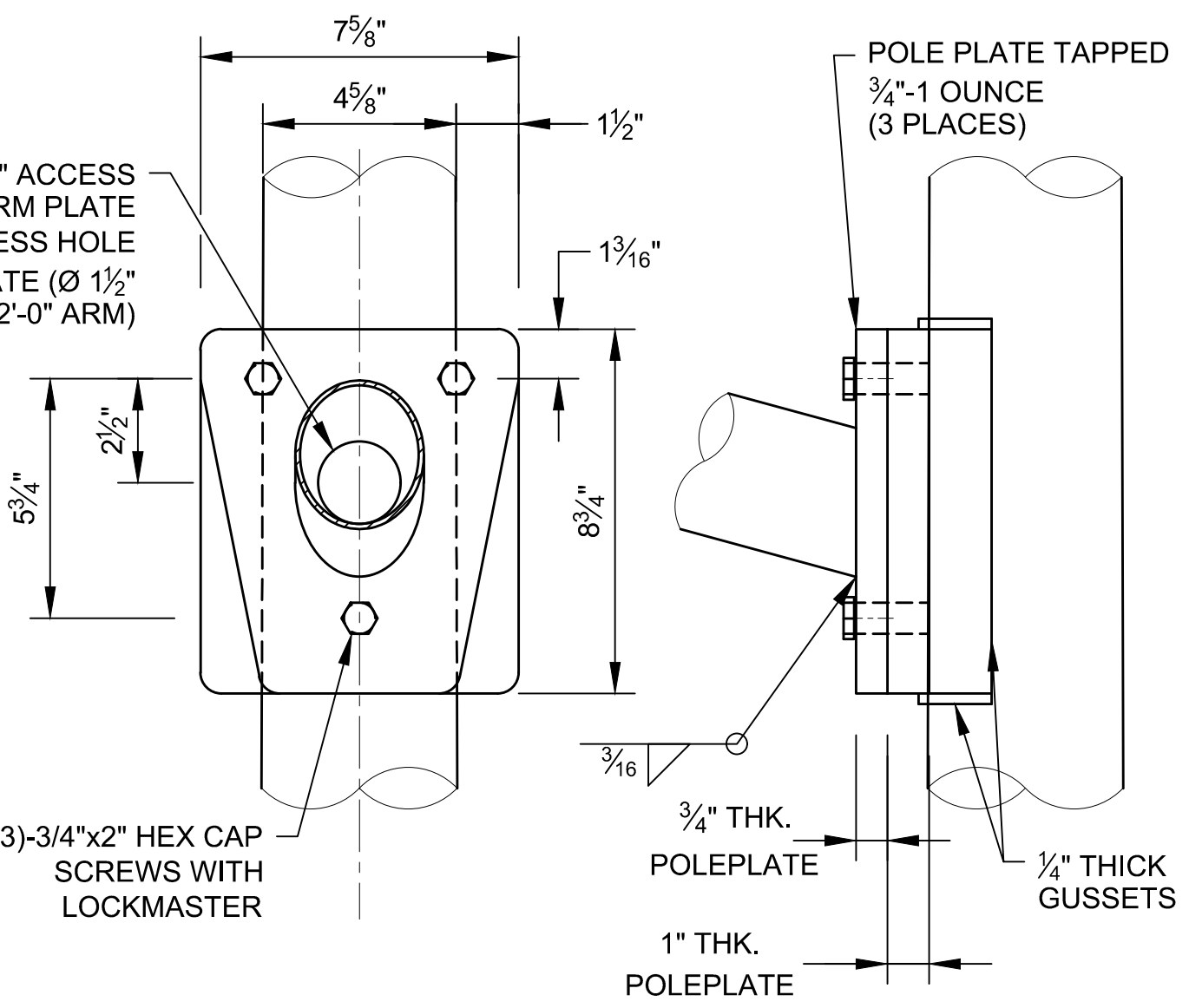
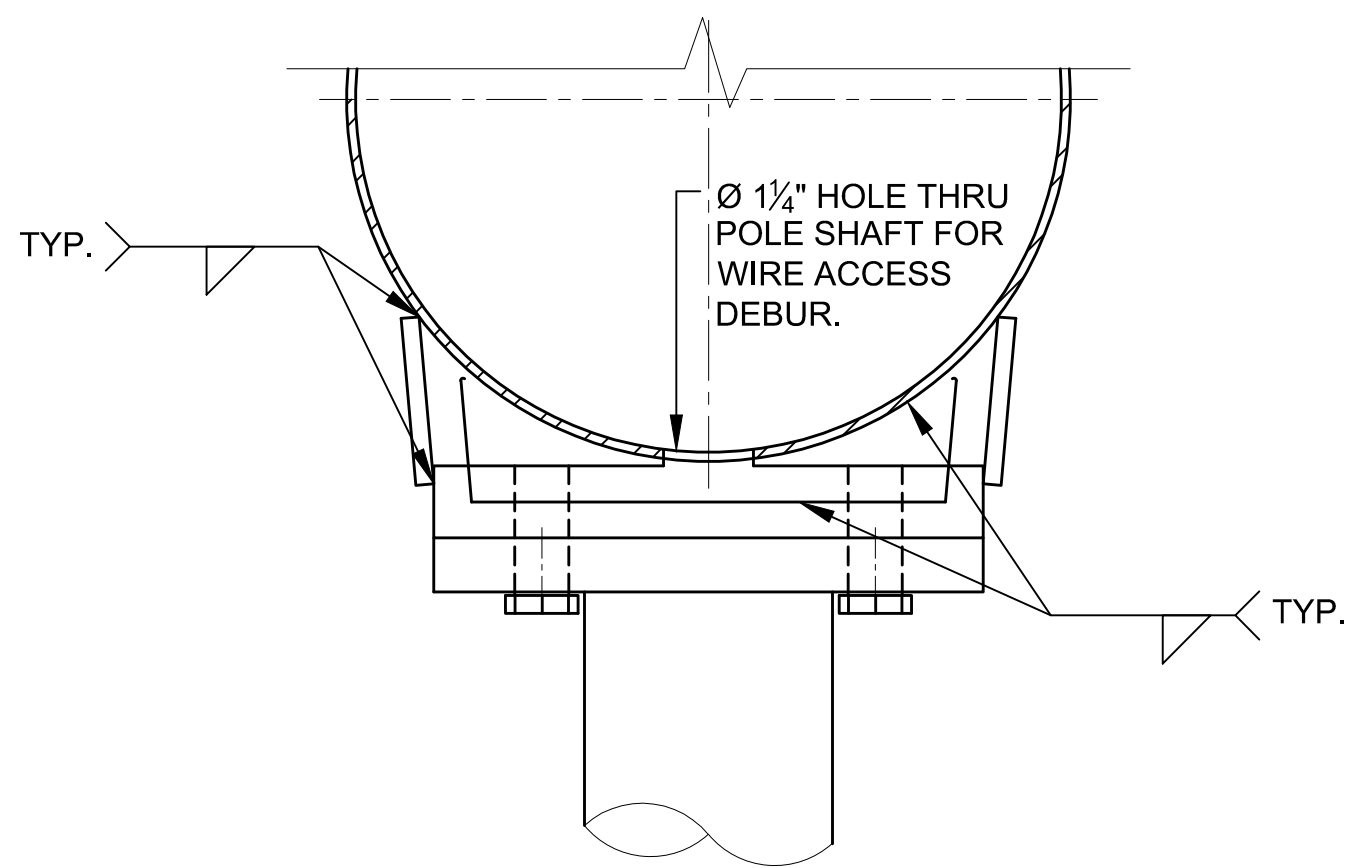

MAST ARM FLANGE
NOT TO SCALE

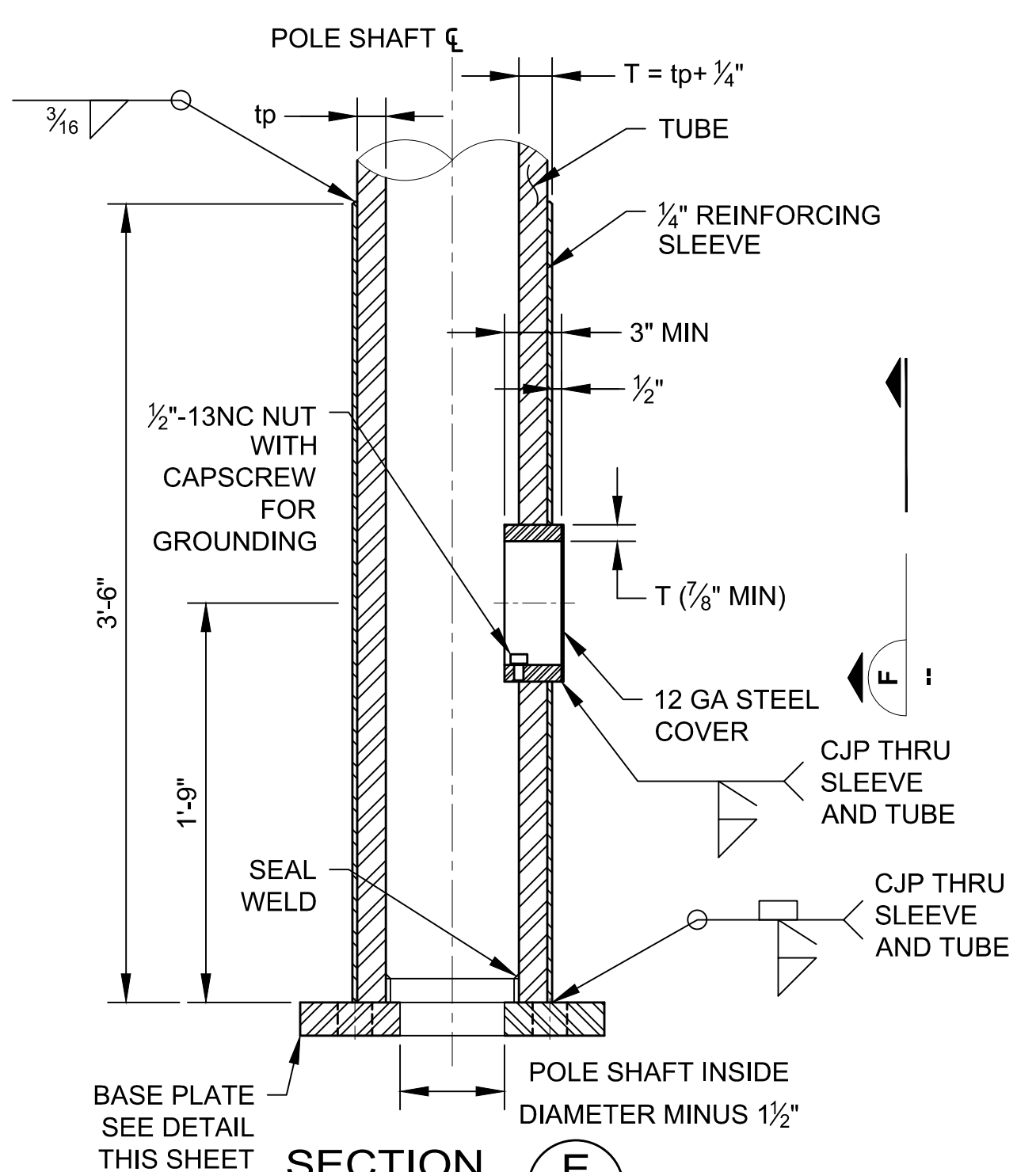

SECTION E
REINFORCING SLEEVE, BASE PLATE, AND HANDHOLE
SCALE: 1 1/2" = 1'-0"

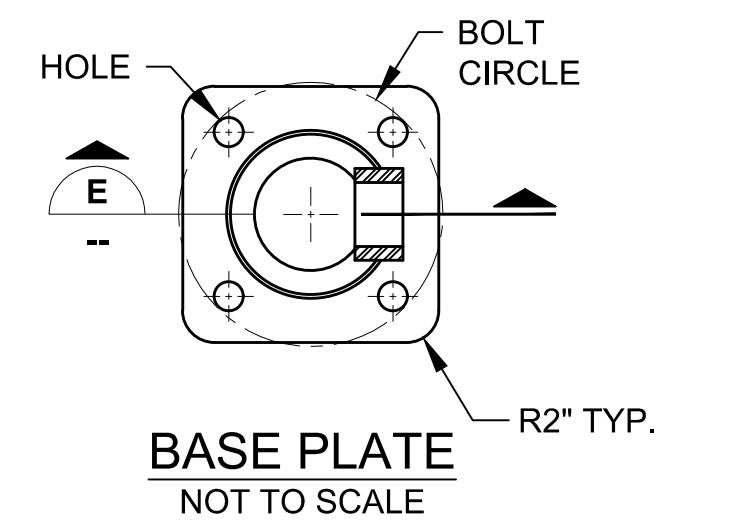

BASE PLATE
NOT TO SCALE

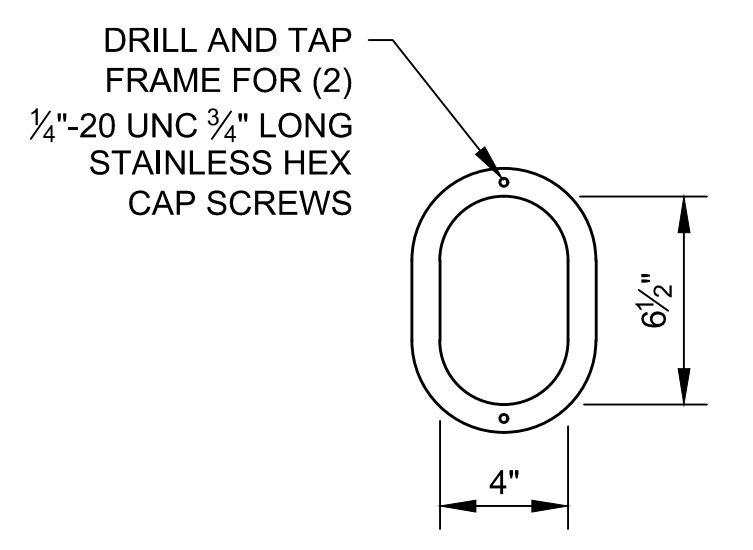

SECTION F
HANDHOLE (WITHOUT COVER)
SCALE: 2" = 1'-0"

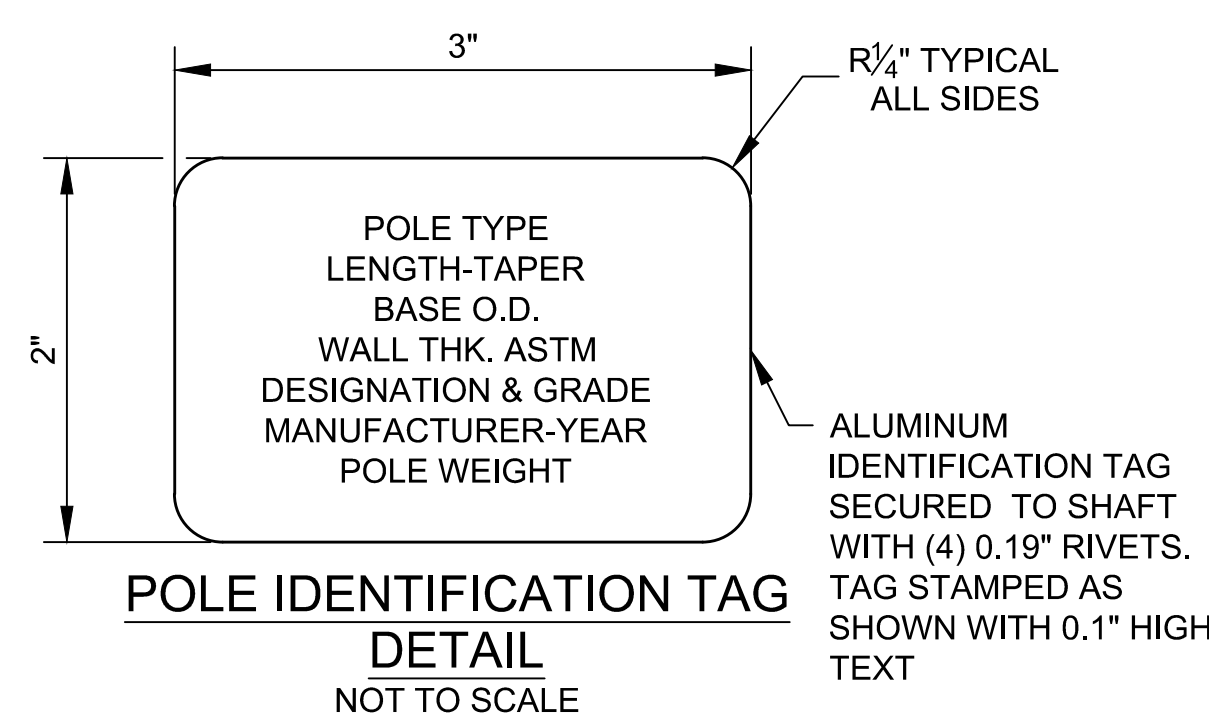

POLE IDENTIFICATION TAG
DETAIL
NOT TO SCALE

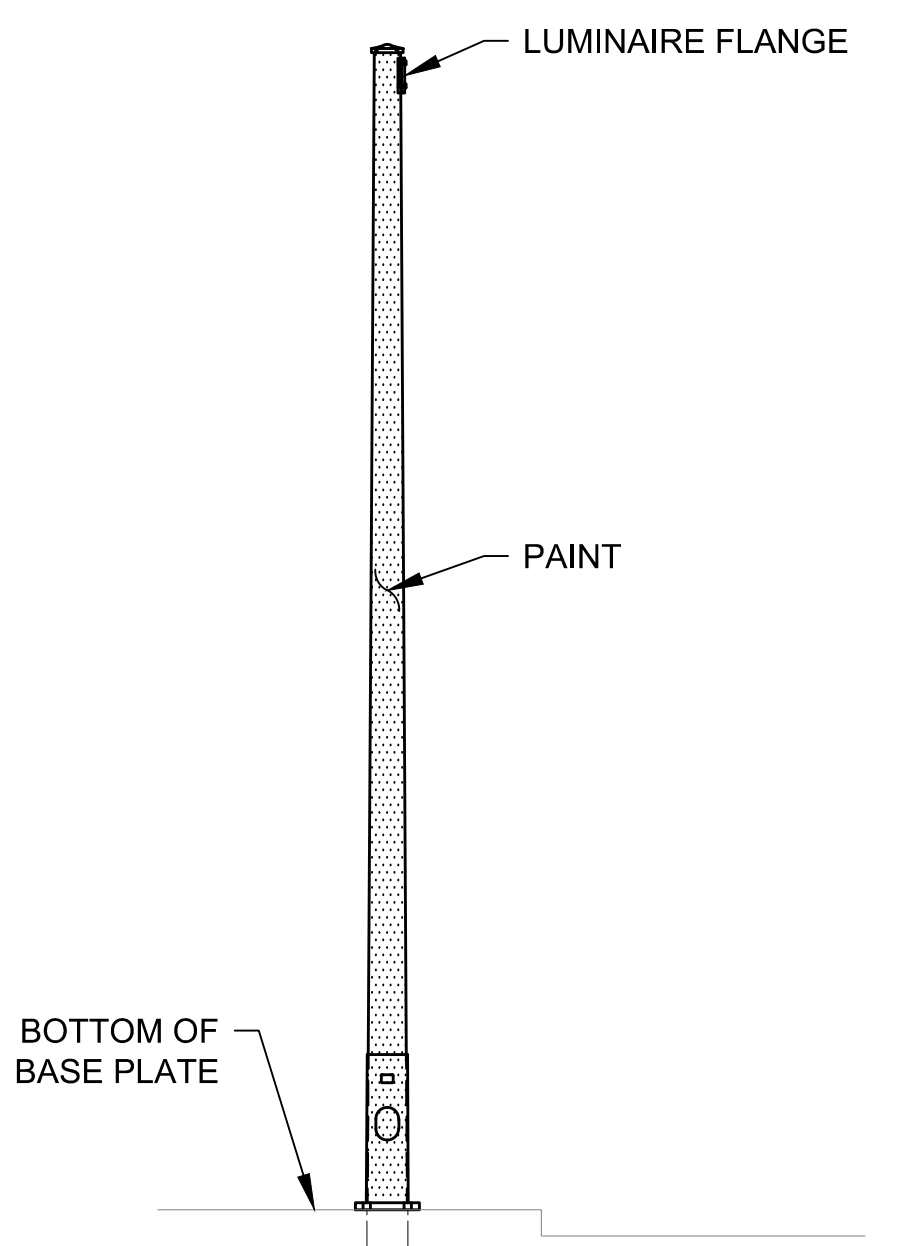

POLE PAINTING EXAMPLE
NOT TO SCALE

POLE PAINTING NOTES:

1. COATING MATERIAL: EPOXY PRIMER, POLYURETHANE FINISH.
2. SURFACE PREPARATION: WASH WITH A MILD SOLUTION OF DETERGENT AND HOT WATER. RINSE COMPLETE AND ALLOW TO DRY, PREPARE FOR PAINT APPLICATION BY PROVIDING A SSPC SP-2 (HAND TOOL CREAM).
3. COATING: PRIMER: ONE COAT OF TNEMEC'S 135 CHEMBUILD, APPLIED AT 7-8 MILS DRY FILM THICKNESS. FINISH: ONE COAT OF TNEMEC'S SERIES 74, APPLIED AT 4-5 MILS DRY FILM THICKNESS.
4. COLOR: RAL 6021 POLE GREEN.

Z:\210127\KC University Pole Replacement\CADD\SHEET 26 STS.17 Pole Specifications-2.dwg | Layout: STS.17
PLOTTED: Dec 05, 2025 09:53:33pm By: Jane Work
XREFS: KCDC-BORDER-RHC Engineering IMAGES

No.	REVISION	BY	APP'D	DATE

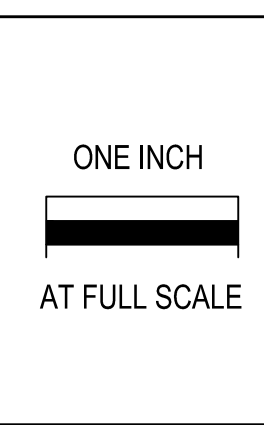

RHC ENGINEERING
WWW.RHCENGINEERING.COM
720 3RD AVE SUITE 1400
SEATTLE WA 98104
PH: 206.623.5984

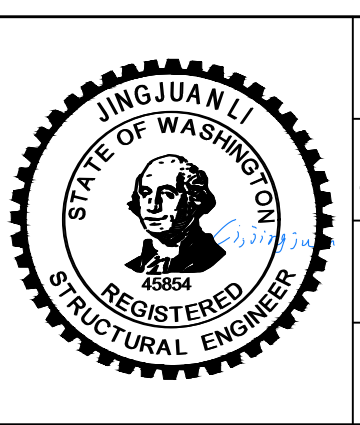

DESIGNED: J. LI	APPROVED: G. FRANCO
DRAWN: T. LOZADA	PROJECT NO.:
CHECKED: G. CHEN	1127254
CHECKED:	CONTRACT NO.:



METRO TRANSIT CAPITAL DIVISION
TROLLEY OVERHEAD SYSTEM
UNIVERSITY BRIDGE TROLLEY POLE REPLACEMENT

POLE SPECIFICATIONS - 2

DATE: DECEMBER 2, 2025
DRAWING NO.:
ST5.17
SHEET NO. OF 26
43

POLE AND FOUNDATION SCHEDULE							
POLE NUMBER ON PLAN	ASSET NUMBER ON TAG	POLE TYPE	POLE DESIGNATION	FOUNDATION TYPE	POLE STATION	POLE OFFSET	EX. SIGNS ON POLE
1E	23E-161	SA-203-2	M, SL	SA-213-A	0+68.40	30.25 RT	
2E	23E-159	SA-203-2	M, PL	TYPE A	1+49.5	30.25 RT	ONE NO DRINK AND DRIVE SIGN
4E	23E-152	SA-203-2	M, SL	TYPE A	7+03	30.25 RT	
5E	23E-151	SA-203-2	M, PL	TYPE A	7+82.5	30.25 RT	
6E	23E-150	SA-203-2	M	TYPE A	8+62	30.25 RT	
7E	23E-149	SA-203-2	M, PL	TYPE A	9+41.5	30.25 RT	
8E	23E-148	SA-203-2	M, SL	TYPE A	10+19	30.25 RT	
9E	23E-147	SA-203-2	M, PL	TYPE A	10+94	30.25 RT	
10E	23E-145	SA-203-2	M	TYPE A	11+69	30.25 RT	
11E	23E-143	SA-203-2	M, PL	TYPE A	12+14	30.25 RT	FOUR GREEN DIRECTION SIGNS
13E	23E-141	SA-203-2	M, PL	TYPE B	13+95	30.25 RT	
14E	23E-140	SA-203-2	M, SN	TYPE B	14+70	30.25 RT	ONE GREEN AND TWO YELLOW SIGNS
15E	23E-139	SA-203-2	M, SL, PL	TYPE B	15+53	30.25 RT	ONE RIGHT TURN STOP SIGN
16E	23E-138	SA-203-2	M, PL	TYPE B	15+97.00	30.25 RT	
1W	23E-156	SA-203-2	M, PL	SA-213-A	0+68.40	30.25 LT	
2W	23E-155	SA-203-2	M, SL, F	TYPE A	1+49.5	30.25 LT	
3W	23E-153	SA-203-2	M, PL	TYPE A	2+49.5	30.25 LT	
4W	23E-137	SA-203-2	M, PL	TYPE A	7+03	30.25 LT	ONE BLUE AND ONE YELLOW SIGN
5W	23E-136	SA-203-2	M	TYPE A	7+82.5	30.25 LT	ONE YIELD TO PEDESTRIAN SIGN
6W	23E-135	SA-203-2	M, SL, PL	TYPE A	8+62	30.25 LT	
7W	23E-134	SA-203-2	M	TYPE A	9+41.5	30.25 LT	
8W	23E-133	SA-203-2	M, PL	TYPE A	10+19	30.25 LT	
9W	23E-132	SA-203-2	M	TYPE A	10+94	30.25 LT	
10W	23E-131	SA-203-2	M, SL, PL	TYPE A	11+69	30.25 LT	
11W	23E-130	SA-203-2	M	TYPE A	12+14	30.25 LT	
12W	23E-128	SA-203-2	M, PL	TYPE B	13+20	30.25 LT	ONE YIELD TO PEDESTRIAN SIGN
13W	23E-127	SA-203-2	M, F	TYPE B	13+95	30.25 LT	
14W	23E-126	SA-203-2	M, SL, F	TYPE B	14+70	30.25 LT	
15W	23E-124	SA-203-2	M, PL	TYPE B	15+53	30.25 LT	ONE SPEED LIMIT SIGN
16W	23E-122	SA-203-2	M, PL	SA-213-A	15+97.00	30.25 LT	ONE WAY SIGN
S1	23E-125	SA-201Z	M	SEE POLE FOUNDATION NOTES	14+13	33.50 RT	
S2	23E-123	SA-201Z	M	SEE POLE FOUNDATION NOTES	14+13	33.50 LT	

POLE SCHEDULE NOTES





- POLE MANUFACTURER SHALL DESIGN POLE BASED ON THE DATA SHOWN HERE AND IN CONFORMANCE TO THE KING COUNTY METRO STANDARD PLAN SA AND SP DRAWINGS AND SPECIFICATIONS.
- MINIMUM WALL THICKNESS SHALL BE 3 GAGE. WALL SHALL BE SINGLE PLY AND THE SAME MATERIAL FULL LENGTH.
- MINIMUM GROUND LINE MOMENT AT YIELD SHALL BE NO LESS THAN (My) AS SPECIFIED IN THE TABLE.
- THE LATERAL DEFLECTION OF THE TOP OF EACH POLE RESULTING FROM THE WORKING LOAD SHALL NOT EXCEED 2.5% OF THE POLE LENGTH FOR POLE DIAMETERS ≥ 12" AND 3% FOR POLE DIAMETERS < 12".
- STRENGTH CALCULATIONS SHALL BE BASED ON GROUND LINE DIAMETER ONLY AND SHALL NOT INCLUDE THE REINFORCING SLEEVE.
- REFER TO SHEETS ST5.16 AND ST5.17 AND METRO STANDARD PLANS SP-201 FOR STEEL STRAIN POLE DETAILS AND SPECIFICATIONS.
- POLE DESIGNATION WITH JOINT USE ATTACHMENTS:
 - M: METRO TROLLEY
 - SL: STREET LIGHTING
 - PL: PEDESTRIAN LIGHT
 - SN: SIGN
 - F: TROLLEY FEEDER POLE
- CONTRACTOR SHALL SUPPLY AND INSTALL STREET LUMINAIRES AND PEDESTRIAN LIGHTS BASED ON THE POLE SCHEDULE IN THIS SHEET. THE STREET LIGHTING LUMINAIRES SHALL BE SEATTLE CITY LIGHT STOCK NUMBER 5723.71, THE PEDESTRIAN LIGHTING LUMINAIRES SHALL BE SEATTLE CITY LIGHT STOCK NUMBER 5723.11.
- CONTRACTOR SHALL SUPPLY AND INSTALL STREET LUMINAIRES TO EXISTING POLES 3E AND 12E THAT ARE NOT LISTED IN THE POLE SCHEDULE.
- CONTRACTOR SHALL PRESERVE AND REINSTALL ALL TRAFFIC SIGNS ON THE EXISTING POLES. CONTRACTOR SHALL MAINTAIN AN INVENTORY OF ALL EXISTING SIGNS AND MOUNTING HEIGHTS FOR EXISTING POLES TO BE REINSTALLED AFTER POLE REPLACEMENT, THESE SIGNS INCLUDE BUT ARE NOT LIMITED TO THE SIGNS SHOW IN THE POLE SCHEDULE TABLE. CONTRACTOR SHALL FIELD VERIFY ALL EXISTING SIGNS AND MAINTAIN ALL TRAFFIC SIGNS DURING CONSTRUCTION.
- CONTRACTOR SHALL PLACE SEATTLE CITY LIGHT POLE INVENTORY TAGS IN ACCORDANCE WITH SEATTLE CITY LIGHT CONSTRUCTION STANDARD 0093.12. CONTRACTOR SHALL SURVEY THE EXISTING POLE TAGS AND USE THE SAME NUMBER ON NEW POLES AT EACH LOCATION.
- POLES, ANCHORS BOLTS, AND LUMINAIRE BRACKETS WILL BE SUPPLIED BY KING COUNTY. CONTRACTOR IS RESPONSIBLE FOR TRANSPORTING THESE PARTS FROM KING COUNTY STORAGE SITE TO THE BRIDGE SITE FOR CONSTRUCTION. CONTRACTOR SHALL BE RESPONSIBLE FOR ANY DAMAGE TO THE PARTS DURING TRANSPORTATION AND CONSTRUCTION.

POLE DETAIL SCHEDULE (WITHOUT SLEEVES)									
POLE TYPE	POLE STYLE	NORMAL LENGTH (FEET)	MAX. GROUND LINE ACROSS FLATS (INCHES)	WORKING LOAD (LB) @ 25' FOR Δ D ONLY	(MY) GROUND LINE MOMENT (LB-FT)	BASE PLATE DIMENSION (INCHES)	BASE PLATE THICKNESS (INCHES)	BASE PLATE BOLT CIRCLE DIAMETER (INCHES)	BASE PLATE BOLT HOLE DIAMETER (INCHES)
SA-203-2	ANCHOR BASE	28'-6"	10	2000	100,000	16X16	1 3/4	15	1 13/16
SA-201-Z	ANCHOR BASE	33'-6"	15	6600	330,000	23X23	2 1/2	22	2 13/16

POLE FOUNDATION NOTES

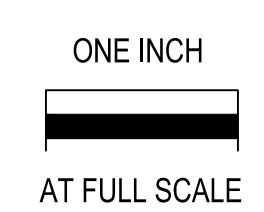
- TYPE A: POLE FOUNDATION ON BRIDGE STEEL APPROACH SPANS
 - TYPE B: POLE FOUNDATION ON BRIDGE CONCRETE APPROACH SPANS
 - TYPE SA-: METRO STANDARD POLE FOUNDATION ON GROUND
- FOUNDATIONS FOR POLES S1 AND S2 ARE BRACKETS MOUNTED ON THE SUPERBENT, SEE SHEETS ST5.08 TO ST5.13 FOR MOUNTING DETAILS.
- SEE SHEETS ST5.01 TO ST5.03 FOR TYPE A, TYPE B, AND TYPE SA FOUNDATION DETAILS.

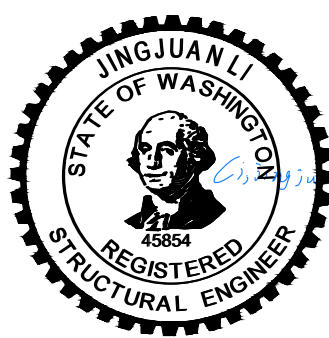
Z:\210127\KC University Pole Replacement\CADD\SHEET 27 ST6.01 TROLLEY POLE AND FOUNDATION SCHEDULE.dwg | Layout: ST6.01
 PLOTTED: Dec 19, 2024 10:58:46am By: Jane Work
 XREFS: KCDC-BORDER-RHC Engineering IMAGES

		 <p>RHC ENGINEERING WWW.RHCENGINEERING.COM 720 3RD AVE SUITE 1400 SEATTLE WA 98104 PH: 206.623.5984</p>		DESIGNED: J. LI DRAWN: T. LOZADA CHECKED: G. CHEN - - - -	APPROVED: G. FRANCO PROJECT NO: 1127254 CONTRACT NO: -		METRO TRANSIT CAPITAL DIVISION TROLLEY OVERHEAD SYSTEM UNIVERSITY BRIDGE TROLLEY POLE REPLACEMENT TROLLEY POLE REPLACEMENT SCHEDULE	DATE: DECEMBER 2, 2025 DRAWING NO: ST6.01 SHEET NO. OF 27 OF 43	
No.	REVISION	BY	APPD	DATE					

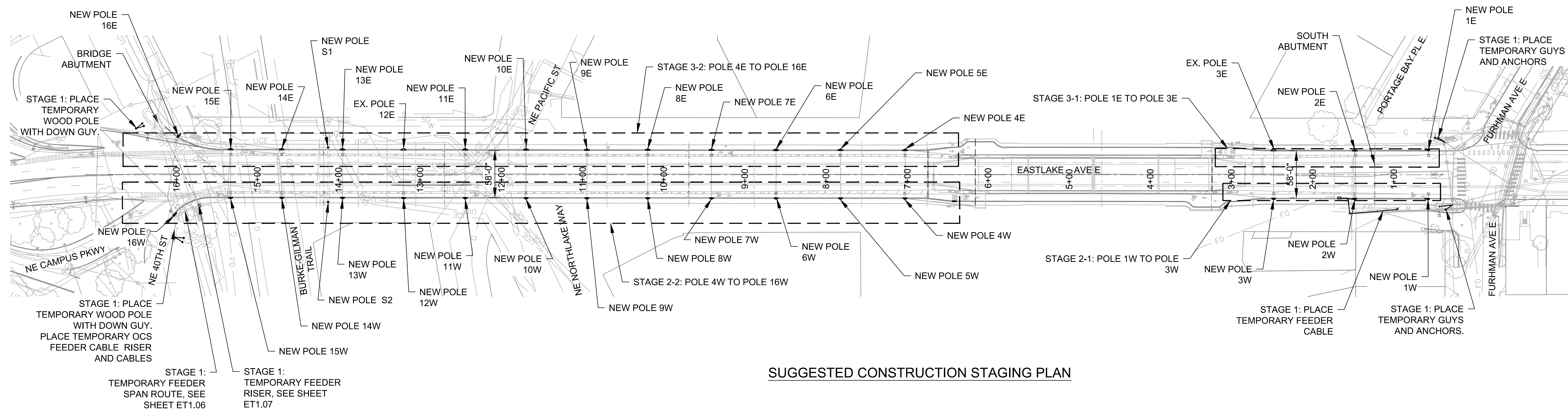
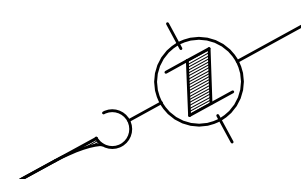

SUGGESTED CONSTRUCTION STAGING PLAN

SUGGESTED CONSTRUCTION SEQUENCE:

- STAGE 1: TROLLEY OCS REMOVAL ON THE BRIDGE
- A. PLACE TEMPORARY WOOD POLES AT NORTH END AND SIDEWALK GUYS AT NORTH AND SOUTH ENDS OF THE BRIDGE, INSTALL TEMPORARY CONDUIT RISER AND FEEDER CABLES BY CONTRACTOR
 - B. METRO TO INSTALL TROLLEY OCS TEMPORARY DEADEND AND OCS TEMPORARY FEEDER SPANS
 - C. METRO TO REMOVE EXISTING TROLLEY OCS WIRES ON THE BRIDGE
- POLE REPLACEMENT CONSTRUCTION, SEE SHEETS CSP.02 TO CSP.05 FOR DETAILS.
- STAGE 2: POLE REPLACEMENT ON ONE SIDE OF THE BRIDGE BY CONTRACTOR
- 1. REMOVE EX. AND CONSTRUCT NEW POLES ON SOUTH END OF THE DRAW BRIDGE. REPLACE LIGHTING POWER CONDUITS AND LUMINAIRES. MAINTENANCE EX. LIGHTING DURING CONSTRUCTION.
 - 2. REMOVE EX. AND CONSTRUCT NEW POLES ON THE NORTH END OF THE DRAW BRIDGE. REPLACE LIGHTING POWER CONDUITS AND LUMINAIRES. MAINTENANCE EX. LIGHTING DURING CONSTRUCTION.
- STAGE 3: SHIFT THE CONSTRUCTION TO THE OTHER SIDE OF THE BRIDGE AND REPEAT STEPS 1 & 2 IN STAGE 2.
- STAGE 4: METRO INSTALL OCS WIRES
- STAGE 5: CONTRACTOR REMOVE TEMPORARY DEADEND POLES AND ANCHORS, TEMPORARY FEEDER SPAN CONDUITS AND RISERS.

NOTES:

1. CONTRACTOR TO SUBMIT TRAFFIC CONTROL PLAN FOR ALL STAGES OF CONSTRUCTION FOR APPROVAL PRIOR TO BEGINNING OF WORK.
2. NO CONSTRUCTION DEBRIS SHALL BE ACCUMULATED ON BRIDGE. ALL DEBRIS SHALL BE HAULED BY TRUCK RIGHT AFTER CONCRETE REMOVAL. THE EXISTING POLES SHALL BE DISPOSED TO AN APPROPRIATE FACILITY THAT ACCEPTS LEAD PAINT.
3. ALL CONSTRUCTION LOADS ON THE BRIDGE SHALL NOT EXCEED THE EXISTING BRIDGE LOAD LIMIT. CONTRACTOR TO SUBMIT CONSTRUCTION VEHICLE LAYOUT ON THE EXTERIOR LANE FOR ENGINEER'S APPROVAL PRIOR TO CONSTRUCTION.
4. CONTRACTOR TO NOTIFY KING COUNTY METRO TROLLEY IMPACTS FOR WORK TO BE COMPLETED BY POWER DISTRIBUTION PER REQUIREMENTS OF DIVISION 01 OF THIS CONTRACT.

Z:\210127\KC University Pole Replacement\CADD\Sheet 28 CSP.01 Construction Sequence.dwg | Layout: CSP.01
 PLOTTED: Dec 05, 2025 02:22:17pm By: Jane Wok
 XREFS: KCM University Bridge Trolley_2D BaseMap; KCTDC-BORDER-RHC Engineering IMAGES

No.	REVISION	BY	APPD	DATE

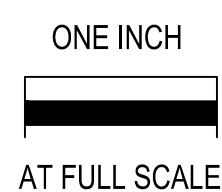

RHC ENGINEERING
 WWW.RHCENGINEERING.COM
 720 3RD AVE SUITE 1400
 SEATTLE WA 98104
 PH: 206.623.5984

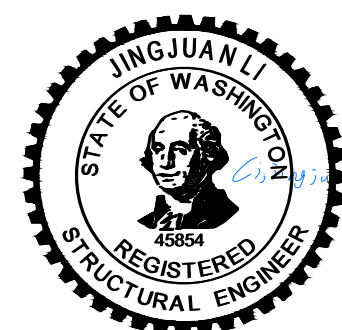

DESIGNED: J. LI	APPROVED: G. FRANCO
DRAWN: T. LOZADA	PROJECT NO: 1127254
CHECKED: G. CHEN	CONTRACT NO: -
CHECKED: -	CHECKED: -



METRO TRANSIT CAPITAL DIVISION
 TROLLEY OVERHEAD SYSTEM
 UNIVERSITY BRIDGE TROLLEY POLE REPLACEMENT
CONSTRUCTION SEQUENCE

DATE: DECEMBER 2, 2025
DRAWING NO: CSP.01
SHEET NO. OF 28 43

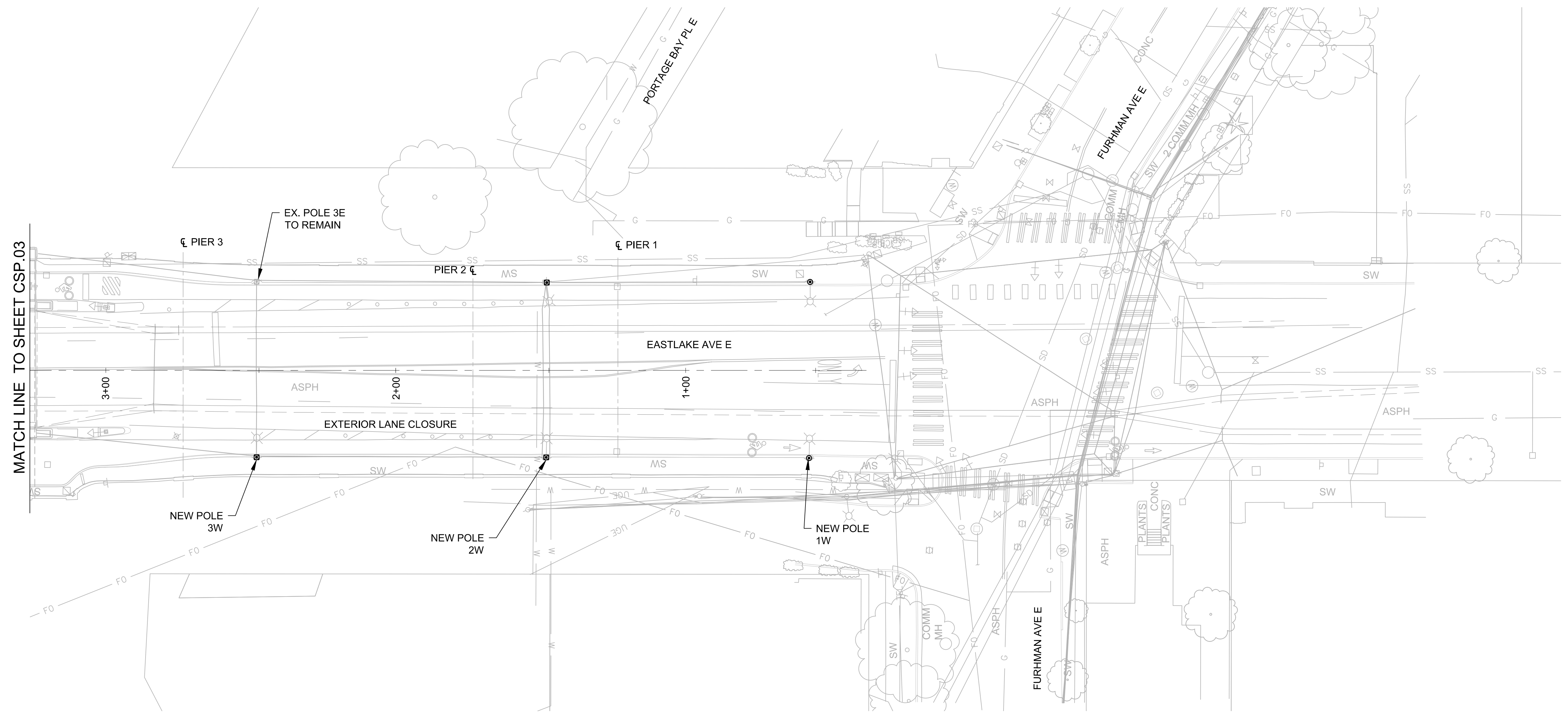
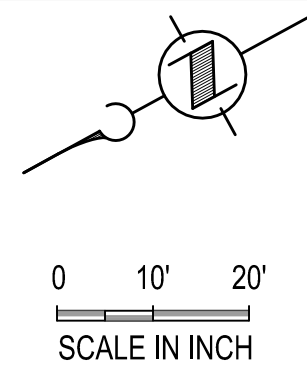

PLAN

NOTES:

1. SEE SHEET CSP.01 FOR GENERAL NOTES.
2. CONSTRUCT POLES REPLACEMENT FOR 1W, 2W AND 3W REPLACEMENT INCLUDING CONDUIT, WIRING, AND LUMINAIR REPLACEMENT.

Z:\210127 KC University Pole Replacement\CADD\SHHEET 29-32 CSP.02.05 Construction Sequences.dwg | Layout: CSP.02
 PLOTTED: Dec 05, 2025 09:20:23pm By: Jane Work
 XREFS: KCM University Bridge Trolley_2D Base.mxd; KCTDC-BORDER-RHC Engineering IMAGES

No.	REVISION	BY	APP'D	DATE

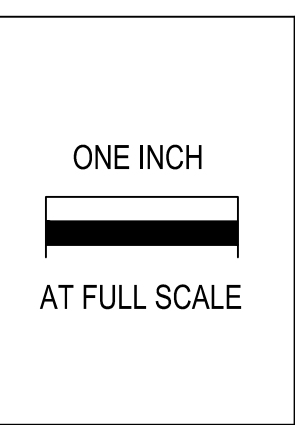

RHC ENGINEERING
 WWW.RHCENGINEERING.COM
 720 3RD AVE SUITE 1400
 SEATTLE WA 98104
 PH: 206.623.5984

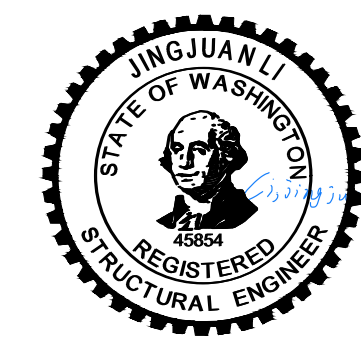

DESIGNED: J. LI	APPROVED: G. FRANCO
DRAWN: T. LOZADA	PROJECT NO: 1127254
CHECKED: G. CHEN	CONTRACT NO: -
CHECKED: -	



METRO TRANSIT CAPITAL DIVISION
 TROLLEY OVERHEAD SYSTEM
 UNIVERSITY BRIDGE TROLLEY POLE REPLACEMENT

**CONSTRUCTION SEQUENCE
 STAGE 2 - 1**

DATE: DECEMBER 2, 2025
DRAWING NO: CSP.02
SHEET NO. OF 29 43

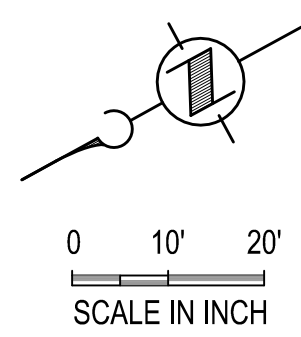

MATCH LINE THIS SHEET

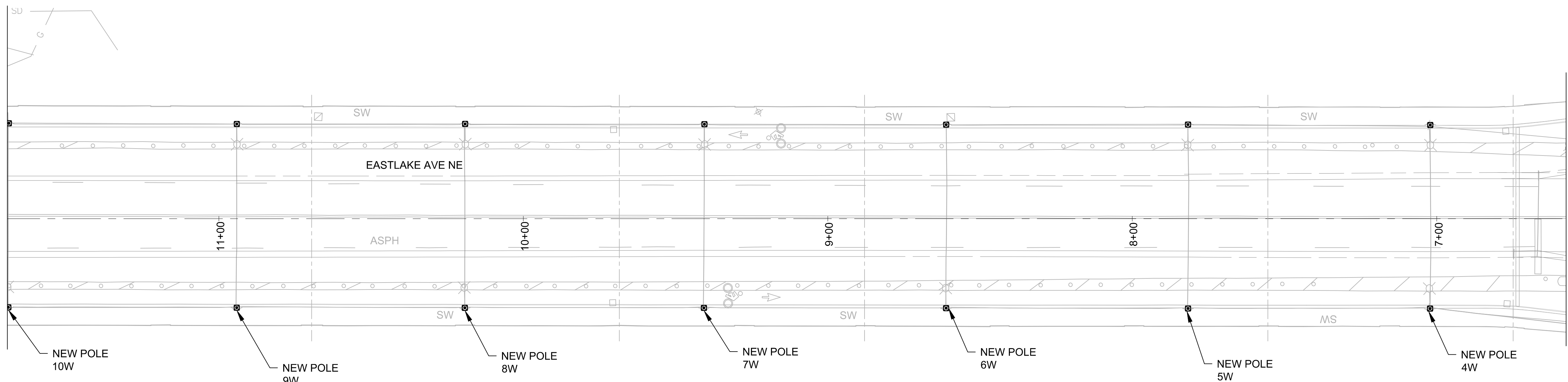

MATCH LINE TO SHEET CSP.02

BASCULE SPAN

PLAN



MATCH LINE THIS SHEET

PLAN

NOTES:

1. SEE SHEET CSP.01 FOR GENERAL NOTES.
2. CONSTRUCT POLES REPLACEMENT FOR 4W TO 16W, POLE S2, AND CONDUIT, WIRING, AND LUMINAIRE REPLACEMENT.

Z:\210127 KC University Pole Replacement\CADD\SHEET 29-32 CSP.02.05 Construction Sequence.dwg | Layout: CSP.03
 PLOTTED: Dec 05, 2025 09:18:53pm By: Jane Wolk
 XREFS: KCM University Bridge Trolley_2D BaseMap; KCTDC-BORDER-RHC Engineering IMAGES.

No.	REVISION	BY	APPD	DATE

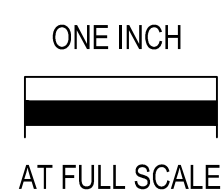

RHC ENGINEERING
 WWW.RHCENGINEERING.COM
 720 3RD AVE SUITE 1400
 SEATTLE WA 98104
 PH: 206.623.5984

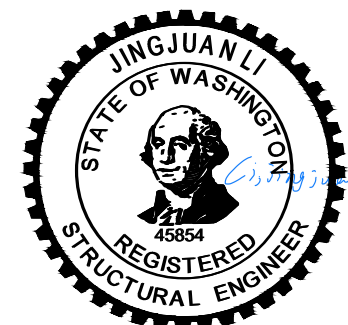

DESIGNED: J. LI	APPROVED: G. FRANCO
DRAWN: T. LOZADA	PROJECT NO: 1127254
CHECKED: G. CHEN	CONTRACT NO:
CHECKED:	



METRO TRANSIT CAPITAL DIVISION
 TROLLEY OVERHEAD SYSTEM
 UNIVERSITY BRIDGE TROLLEY POLE REPLACEMENT
**CONSTRUCTION SEQUENCE
 STAGE 2 - 2**

DATE: DECEMBER 2, 2025
DRAWING NO: CSP.03
SHEET NO. OF 30 43

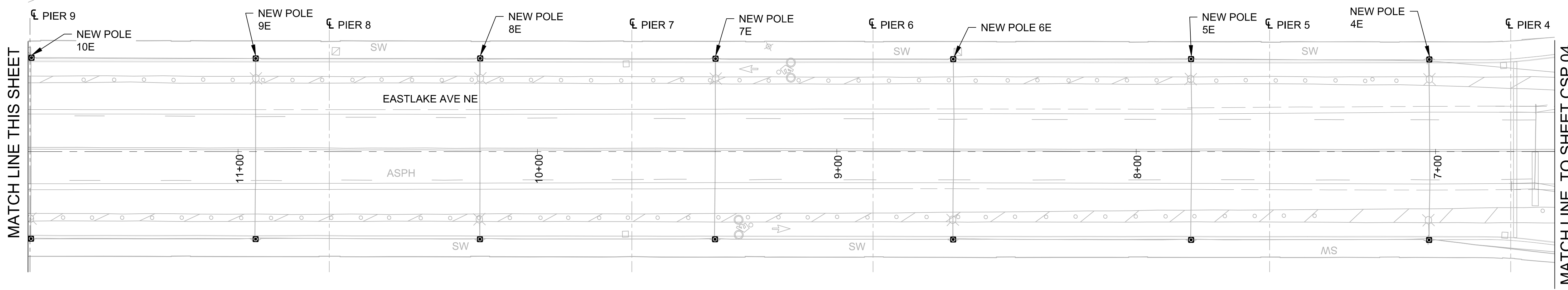
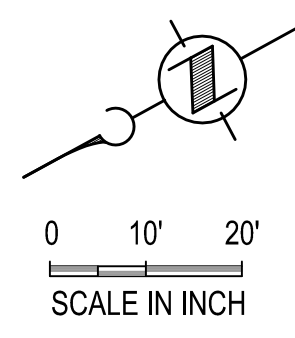

PLAN

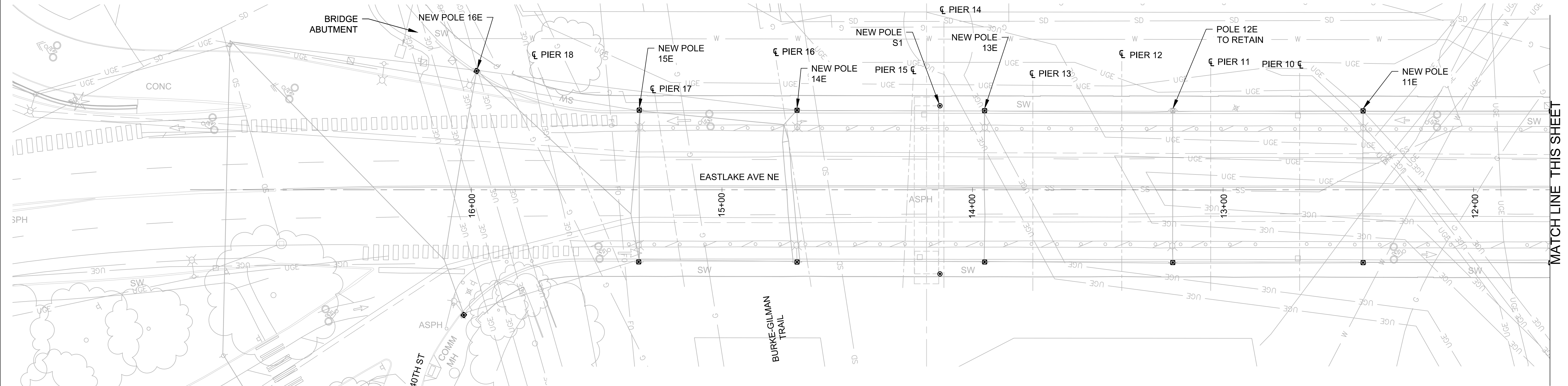

PLAN

- NOTES:**
- SEE NOTES ON SHEET CSP.01.
 - CONSTRUCT POLES 4E TO 11E, 13E TO 16E, AND S1, AND CONDUIT, WIRING, AND LUMINAIRE REPLACEMENT.

Z:\210127 KC University Pole Replacement\CADD\SHEET 29-32 CSP.05-05 Construction Sequences.dwg | Layout: CSP.05
 PLOTTED: Dec 05, 2025 06:30:19pm By: Jane Work
 XREFS: KCM University Bridge Trolley_2D BaseMap; KCTDC-BORDER-RHC Engineering
 IMAGES:

No.	REVISION	BY	APPD	DATE

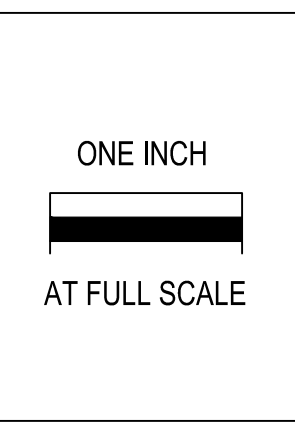

RHC ENGINEERING
 WWW.RHCENGINEERING.COM
 720 3RD AVE SUITE 1400
 SEATTLE WA 98104
 PH: 206.623.5984

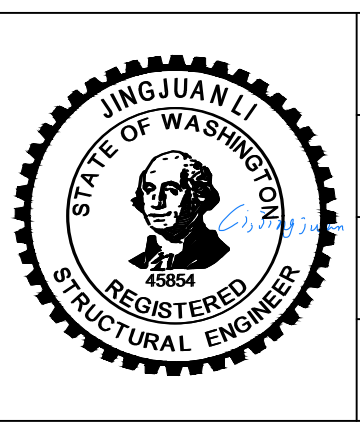

DESIGNED: J. LI	APPROVED: G. FRANCO
DRAWN: T. LOZADA	PROJECT NO: 1127254
CHECKED: G. CHEN	CONTRACT NO: -
CHECKED: ---	



METRO TRANSIT CAPITAL DIVISION
 TROLLEY OVERHEAD SYSTEM
 UNIVERSITY BRIDGE TROLLEY POLE REPLACEMENT

**CONSTRUCTION SEQUENCE
 STAGE 3 - 2**

DATE: DECEMBER 2, 2025
DRAWING NO: CSP.05
SHEET NO. OF 32 43

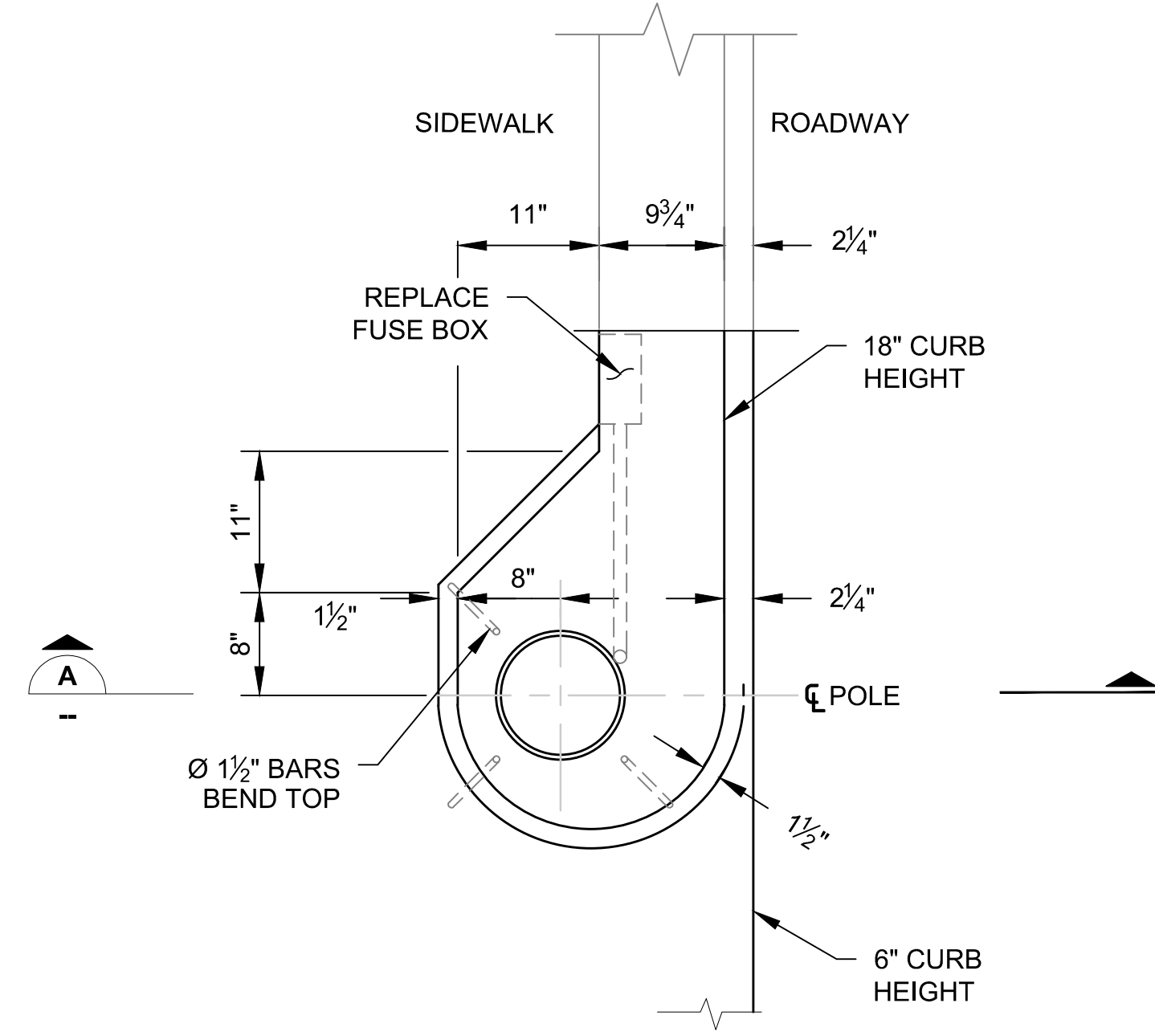
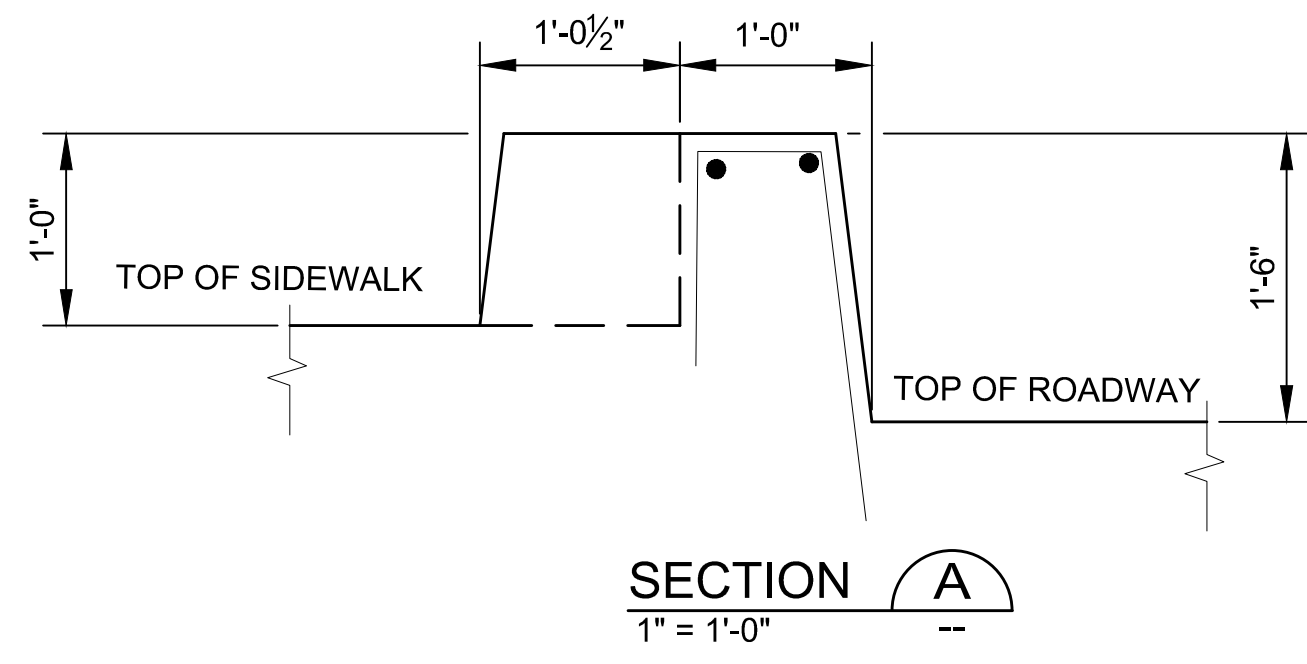

TYPICAL END OF CURB GEOMETRY PLAN
1" = 1'-0"

NOTES:

1. FIELD VERIFY ALL CONDITIONS AND GEOMETRIES, AND UTILITIES, NOTIFY ENGINEER FOR ALL CONFLICTS AND DISCREPANCIES PRIOR TO CONSTRUCTION.
2. MINIMUM AREA OF PAVEMENT SHALL BE DISTURBED DURING SHAFT CONSTRUCTION. AFTER SHAFT CONSTRUCTION, ROADWAY PAVEMENT, SIDEWALK, AND ALL OTHER FEATURES SHALL BE RESTORED IF DISTURBED.
3. SEE SHEET ST5.03 FOR SHAFT DETAILS.
4. SEE CITY OF SEATTLE STANDARD PLAN NO. 420 FOR SIDEWALK DETAILS.

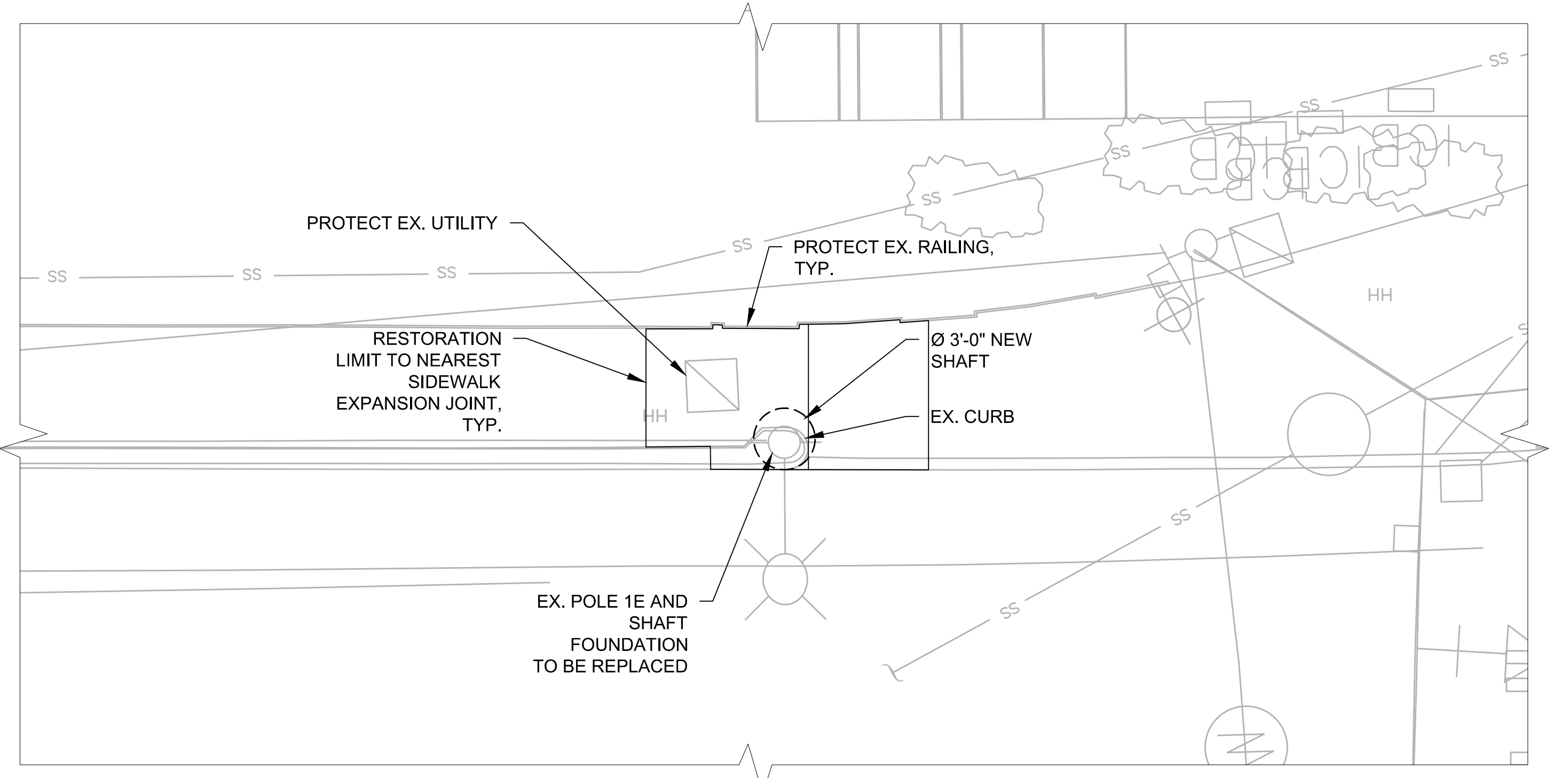
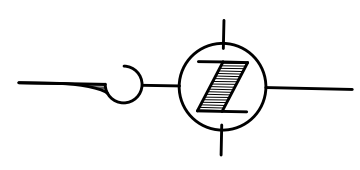

POLE 1E
SCALE: 1" = 5'-0"

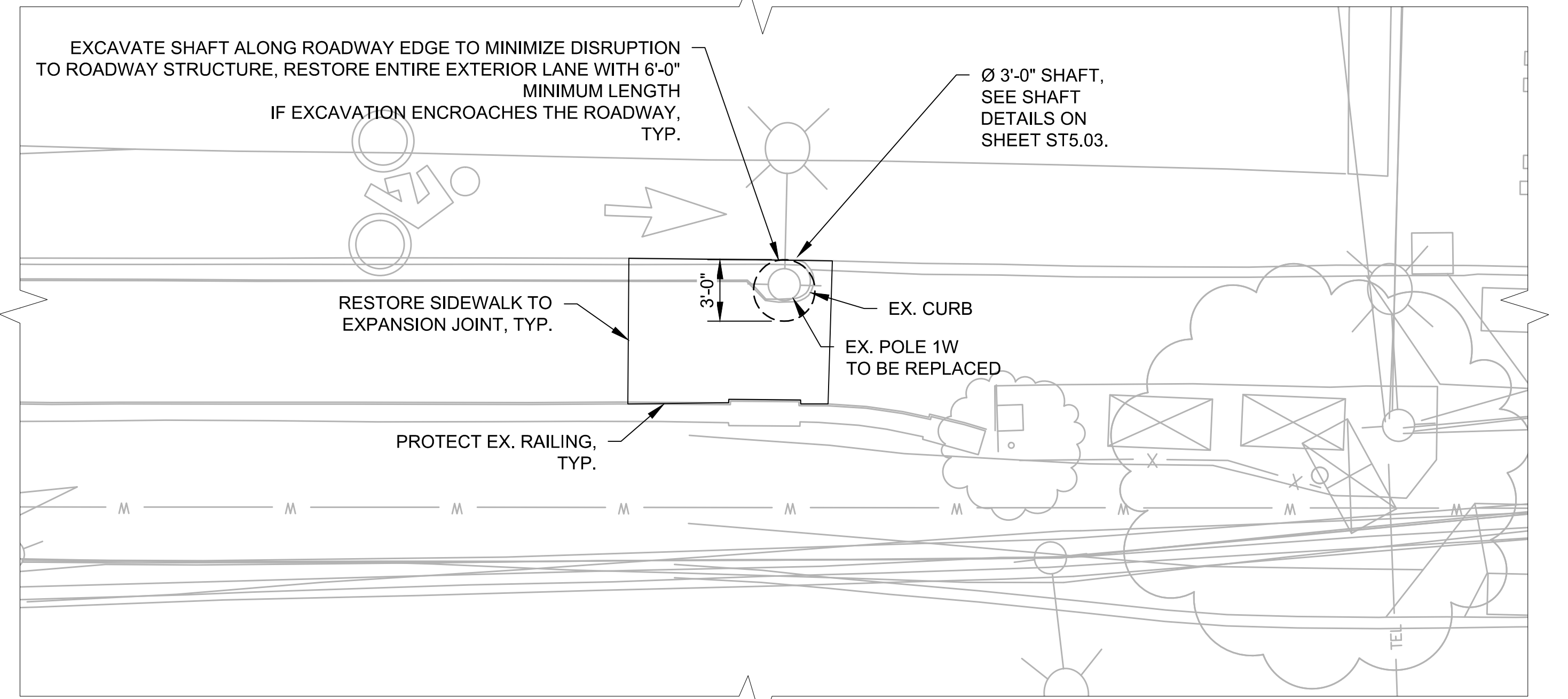

POLE 1W
SCALE: 1" = 5'-0"

Z:\210127\KC University Pole Replacement\CADD\SHEET 03-34 C: 01-02 PAVEMENT RESTORATION PLAN.dwg | Layout: C1.01
 PLOT FILE: Dec 05, 2025 09:56:03am By: Jane York
 XREFS: KCDC-BORDER-RHC Engineering; KCUM University Bridge Trolley_2D BaseMap
 IMAGES:

No.	REVISION	BY	APP'D	DATE

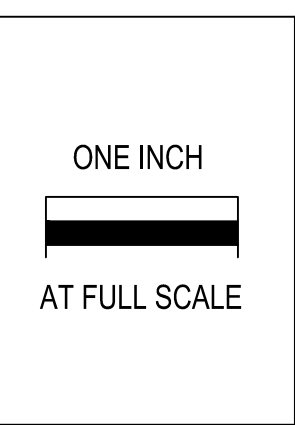

RHC ENGINEERING
 WWW.RHCENGINEERING.COM
 720 3RD AVE SUITE 1400
 SEATTLE WA 98104
 PH: 206.623.5984

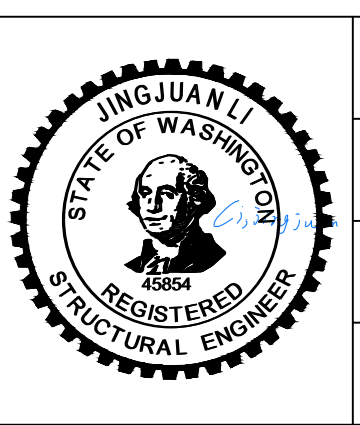

DESIGNED: J. LI	APPROVED: G. FRANCO
DRAWN: T. LOZADA	PROJECT NO: 1127254
CHECKED: G. CHEN	CONTRACT NO: -
CHECKED: -	



METRO TRANSIT CAPITAL DIVISION
 TROLLEY OVERHEAD SYSTEM
 UNIVERSITY BRIDGE TROLLEY POLE REPLACEMENT

SOUTH END PAVEMENT RESTORATION PLAN

DATE: DECEMBER 2, 2025
DRAWING NO: C1.01
SHEET NO. OF 33 43

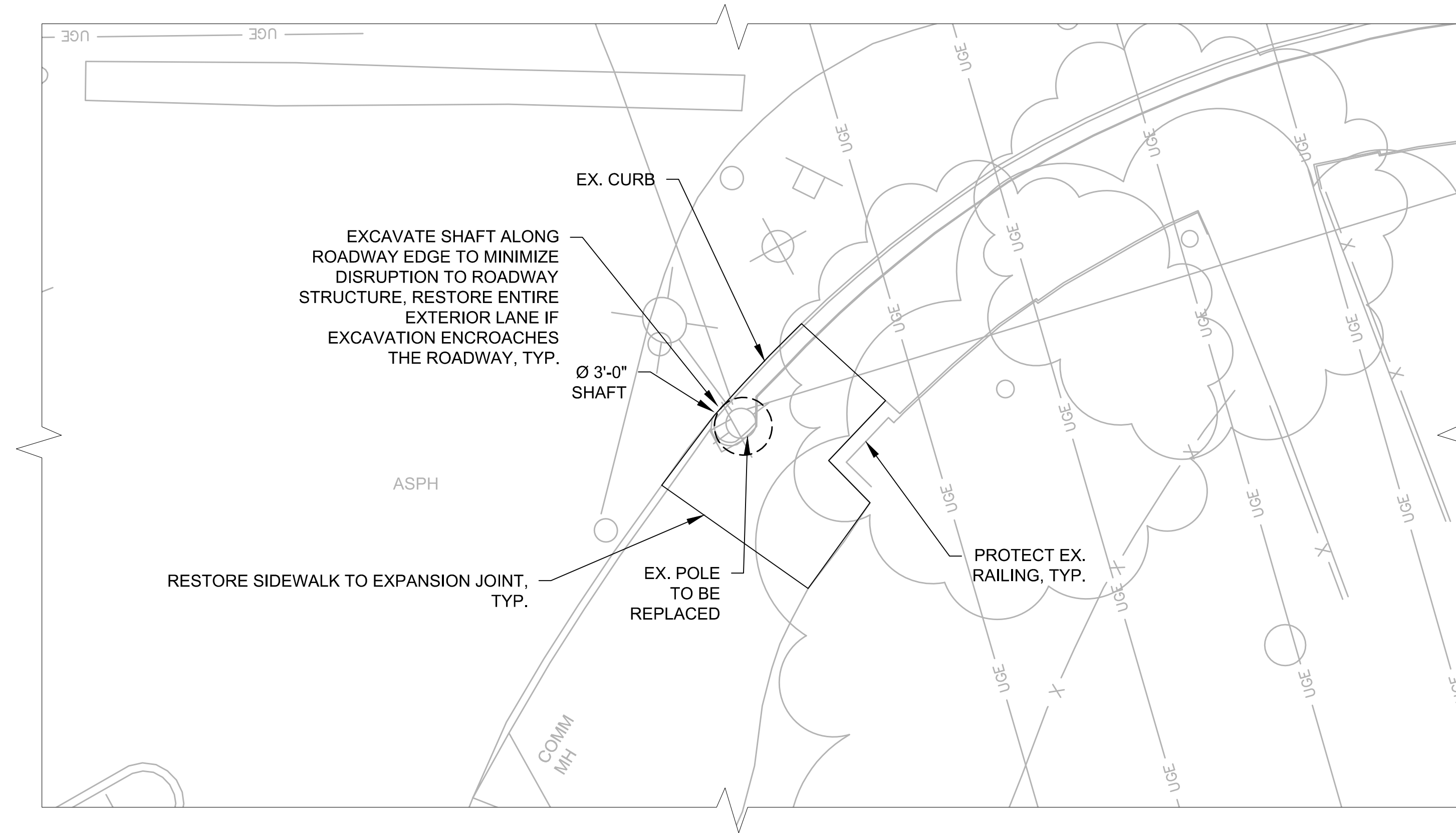
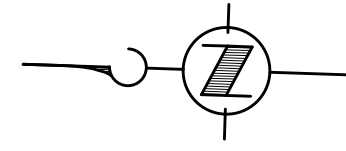

EXCAVATE SHAFT ALONG ROADWAY EDGE TO MINIMIZE DISRUPTION TO ROADWAY STRUCTURE, RESTORE ENTIRE EXTERIOR LANE IF EXCAVATION ENCREACHES THE ROADWAY, TYP.

EX. CURB

Ø 3'-0" SHAFT

ASPH

RESTORE SIDEWALK TO EXPANSION JOINT, TYP.

EX. POLE TO BE REPLACED

PROTECT EX. RAILING, TYP.

COMM MH

POLE 16W
SCALE: 1" = 5'-0"

NOTES:

1. FIELD VERIFY ALL CONDITIONS AND GEOMETRIES, AND UTILITIES, NOTIFY ENGINEER FOR ALL CONFLICTS AND DISCREPANCIES PRIOR TO CONSTRUCTION.
2. REMOVE EXISTING SHAFT PRIOR TO NEW SHAFT CONSTRUCTION.
3. DISTURBANCE TO EXISTING PAVEMENT SHALL BE MINIMIZED. CONTRACTOR MUST RESTORE ALL DISTURBED FEATURES AND UTILITIES DURING EX. SHAFT REMOVAL AND NEW SHAFT CONSTRUCTION.
4. SEE SHEET C1.01 FOR END CURB DETAILS.
5. SEE CITY OF SEATTLE STANDARD PLAN NO. 420 FOR SIDEWALK DETAILS.

Z:\210127\KC University Pole Replacement\CADD\SHEET 03-34 C1.01-02 PAVEMENT RESTORATION PLAN.dwg | Layout: C1.02
 PLOT FILED Dec 03, 2025 09:56:46pm By Jane York
 XREFS: KCDCBORDER-RHC Engineering; KCUM University Bridge Trolley_2D BaseMap IMAGES

No.	REVISION	BY	APP'D	DATE

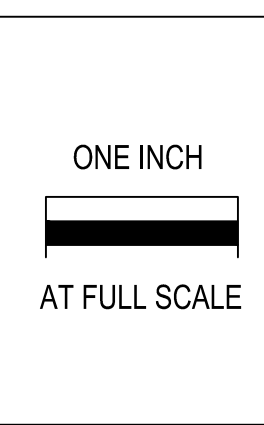

RHC ENGINEERING
 WWW.RHCENGINEERING.COM
 720 3RD AVE SUITE 1400
 SEATTLE WA 98104
 PH: 206.623.5984

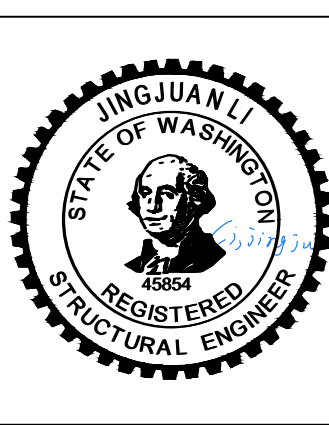

DESIGNED: J. LI	APPROVED: G. FRANCO
DRAWN: T. LOZADA	PROJECT NO: 1127254
CHECKED: G. CHEN	CONTRACT NO: -
CHECKED: -	



METRO TRANSIT CAPITAL DIVISION
 TROLLEY OVERHEAD SYSTEM
 UNIVERSITY BRIDGE TROLLEY POLE REPLACEMENT

NORTH END PAVEMENT RESTORATION PLAN

DATE: DECEMBER 2, 2025
DRAWING NO: C1.02
SHEET NO. OF 34 43

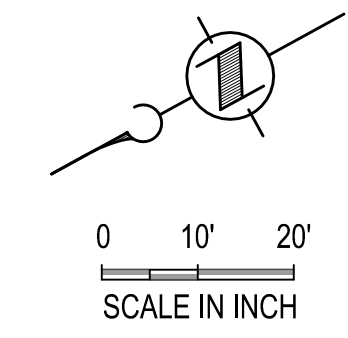
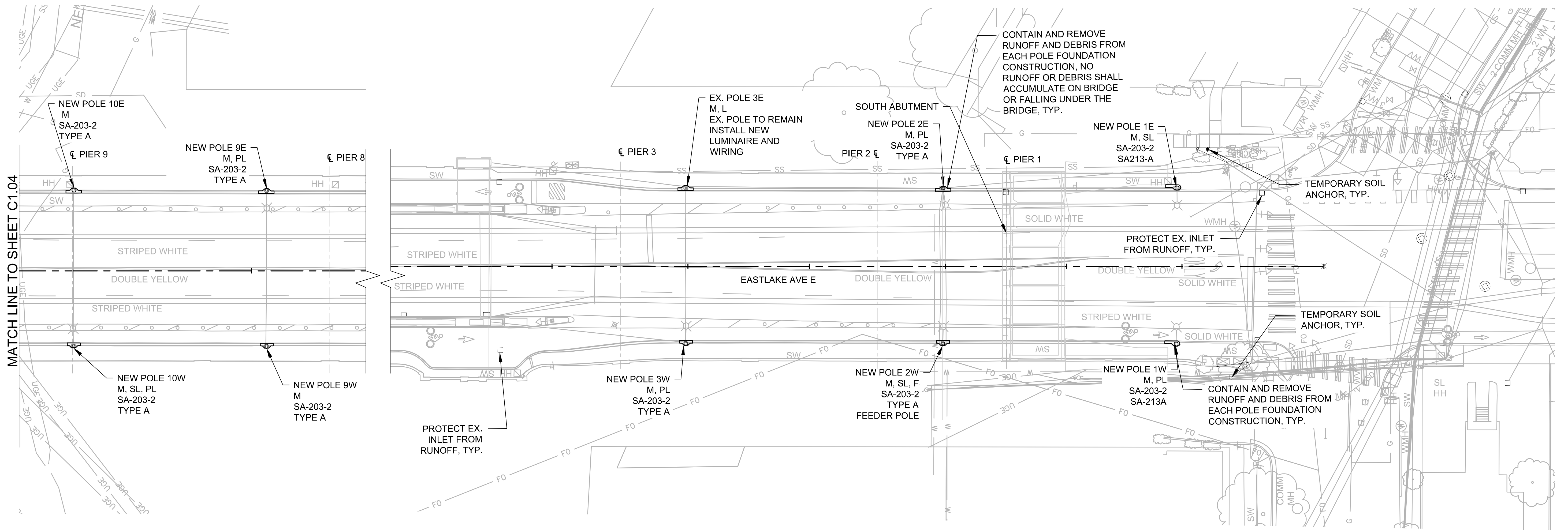

TEMPORARY EROSION AND SEDIMENT CONTROL (TESC)

NOTES:

- AN INITIAL GROUND DISTURBANCE INSPECTION IS REQUIRED PRIOR TO START OF LAND DISTURBING ACTIVITY.
- THE IMPLEMENTATION OF THESE SITE PREPARATION PLANS AND THE CONSTRUCTION, MAINTENANCE, REPLACEMENT, AND UPGRADING OF THESE FACILITIES IS THE RESPONSIBILITY OF THE CONTRACTOR UNTIL ALL CONSTRUCTION WORK IS COMPLETE AND APPROVED.
- STAKE CLEARING LIMITS AND INSTALL TEMPORARY SILT FENCE PRIOR TO THE START OF EARTH DISTURBING ACTIVITIES. DURING THE CONSTRUCTION PERIOD, NO DISTURBANCE BEYOND THE CLEARING LIMITS WILL BE PERMITTED. THE CLEARING LIMITS MUST BE MAINTAINED BY THE CONTRACTOR FOR THE DURATION OF CONSTRUCTION.
- BMPS MUST BE INSTALLED PRIOR TO STARTING CONSTRUCTION TO ENSURE SEDIMENT-LADEN WATER DOES NOT LEAVE THE PROJECT SITE OR ENTER ROADSIDE DITCHES, STORM DRAINS, SURFACE WATERS, OR WETLANDS.
- CONSTRUCT THE TESC FACILITIES IN CONJUNCTION WITH ALL CLEARING AND GRADING ACTIVITIES, AND IN SUCH MANNER AS TO INSURE THAT SEDIMENT LADEN WATER DOES NOT VIOLATE APPLICABLE WATER QUALITY SAFETY STANDARDS.
- THE BMPS INCLUDED IN THIS PLAN ARE THE MINIMUM REQUIREMENTS FOR ANTICIPATED SITE CONDITIONS. THE CONTRACTOR IS RESPONSIBLE FOR ENSURING THE BMPS ARE MODIFIED AS NEEDED FOR UNEXPECTED STORM EVENTS OR OTHER UNFORESEEN CIRCUMSTANCES, AND TO ACCOUNT FOR CHANGING SITE CONDITIONS.
- THE TESC FACILITIES MUST BE CHECKED DAILY FOR FUNCTIONALITY BY THE CONTRACTOR AND MAINTAINED AS NECESSARY OR AS DIRECTED BY THE ENGINEER TO ENSURE CONTINUED FUNCTIONING OF THE SELECTED BMPS.
- ANY AREA STRIPPED OF VEGETATION, WHERE NO FURTHER ACTIVITY IS ANTICIPATED FOR A PERIOD OF 15 DAYS, MUST BE IMMEDIATELY STABILIZED WITH THE APPROVED TESC METHODS (E.G. SEEDING, MULCHING, NETTING, EROSION BLANKETS, ETC).
- STABILIZED WORK SURFACES MUST BE INSTALLED FOR STAGING AREAS AND WHERE EQUIPMENT OR WORK ACCESS IS REQUIRED AT THE BEGINNING OF CONSTRUCTION WORK AND MAINTAINED FOR THE DURATION OF THE PROJECT. ALL SOIL SURFACES MUST BE STABILIZED FOR THE DURATION OF THE PROJECT.
- ANY AREAS OF EXPOSED SOILS, INCLUDING SLOPES AND STOCKPILES, THAT WILL NOT BE DISTURBED FOR TWO DAYS DURING THE PERIOD FROM OCTOBER 1 TO APRIL 30 OR SEVEN DAYS DURING THE PERIOD FROM MAY 1 TO SEPTEMBER 30 MUST BE IMMEDIATELY STABILIZED WITH THE APPROVED TESC METHODS (E.G. SEEDING, MULCHING, NETTING, CLEAR PLASTIC COVERING).
- A CERTIFIED EROSION AND SEDIMENT CONTROL LEAD (CESCL) MUST CONDUCT SITE INSPECTIONS AT LEAST ONCE EVERY CALENDAR WEEK AND WITHIN 24 HOURS OF ANY RUNOFF DISCHARGE FROM SITE AND TO CHECK THAT THE EMPLOYED TESC BMPS ARE FUNCTIONING PROPERLY. AFTER ANY 24-HOUR RUNOFF PRODUCING EVENT, THE CESCL MUST INSPECT CSEC MEASURES FOR INTEGRITY. ANY DAMAGED MEASURES WILL BE BROUGHT TO THE ATTENTION OF THE ENGINEER AND REPAIRED IMMEDIATELY.
- THE CESCL MUST REVIEW AND MODIFY THE TESC PLANS ON AN AS-NEEDED BASIS TO REFLECT ANY MODIFICATIONS TO THE TESC BMPS IN THE FIELD.
- THE CONTRACTOR IS RESPONSIBLE FOR THE SEQUENCING AND STAGING OF ALL SITE PREPARATION AND TESC ACTIVITIES AT APPROPRIATE TIMES.
- SUBMIT A CONSTRUCTION STORMWATER AND EROSION CONTROL PLAN (CSECP), TREE, VEGETATION AND SOIL PROTECTION PLAN (TVSPP), SPILL PLAN (SP), AND TEMPORARY DISCHARGE PLAN (TDP) IN ACCORDANCE WITH CITY OF SEATTLE STANDARD SPECIFICATIONS 8-01.3(2).
- ENSURE THAT WASHOUT FROM CONCRETE TRUCKS IS PERFORMED OFF-SITE OR IN DESIGNATED CONCRETE WASHOUT AREAS ONLY. DO NOT WASH OUT CONCRETE TRUCKS ONTO THE GROUND, OR TO STORM DRAINS OR OPEN DITCHES. DO NOT DUMP EXCESS CONCRETE ONSITE, EXCEPT IN DESIGNATED CONCRETE WASHOUT AREAS.

Z:\210127\KC University Pole Replacement\CADD\SHEET 35-36 C1.03-04 TESC PLAN.dwg | Layout: C1.03
 PLOTTED: Dec 05, 2025 09:41:19pm By: Jane Wolk
 XREFS: KCM University Bridge Trolley_2D BaseMap, SHEET 3-6 T1.01-T1.04 PLAN AND ELEVATION, KCTDC-BORDER-RHC Engineering IMAGES

No.	REVISION	BY	APP'D	DATE

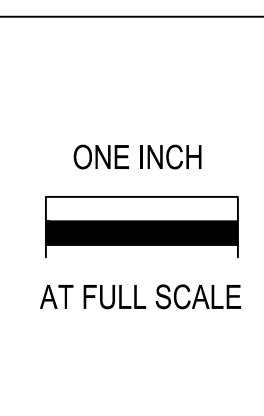

RHC ENGINEERING
 WWW.RHCENGINEERING.COM
 720 3RD AVE SUITE 1400
 SEATTLE WA 98104
 PH: 206.623.5984

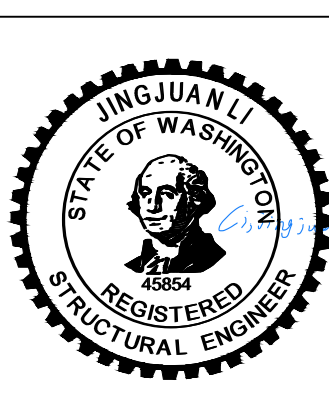

DESIGNED: J. LI	APPROVED: G. FRANCO
DRAWN: T. LOZADA	PROJECT NO: 1127254
CHECKED: G. CHEN	CONTRACT NO: -
CHECKED: -	CHECKED: -



METRO TRANSIT CAPITAL DIVISION
 TROLLEY OVERHEAD SYSTEM
 UNIVERSITY BRIDGE TROLLEY POLE REPLACEMENT

SOUTH END EROSION AND SEDIMENT CONTROL PLAN

DATE: DECEMBER 2, 2025
 DRAWING NO: C1.03
 SHEET NO. OF 35 43

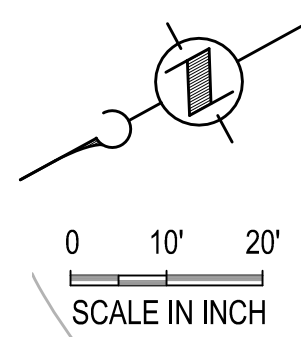

0 10' 20'
SCALE IN INCH

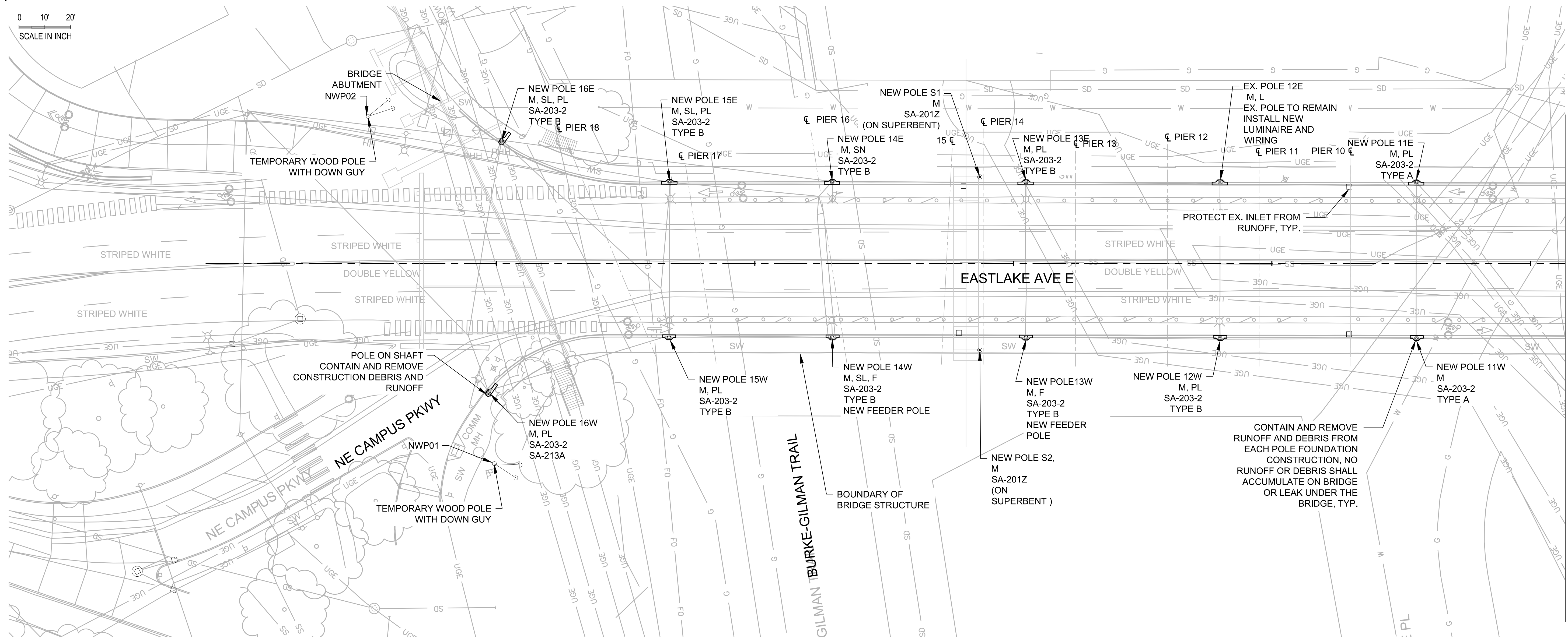

MATCH LINE TO SHEET C1.03

NOTE:

- SEE SHEET C1.03 FOR TEMPORARY EROSION AND SEDIMENT CONTROL NOTES.

Z:\2022\127 KC University Pole Replacement\CADD\SHEET 35-36 C1.03-04 TESC PLAN.dwg | Layout: C1.04 | PLOTTED: Dec 05, 2025 09:24:39pm | By: Jane Work | XREFS: KCM University Bridge Trolley_2D BaseMap, SHEET 3-6 TT.01-TT.04 PLAN AND ELEVATION, KCTDC-BORDER-RHC Engineering IMAGES.

No.	REVISION	BY	APP'D	DATE

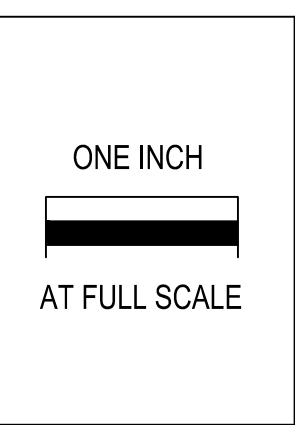

RHC ENGINEERING
WWW.RHCENGINEERING.COM
 720 3RD AVE SUITE 1400
 SEATTLE WA 98104
 PH: 206.623.5984

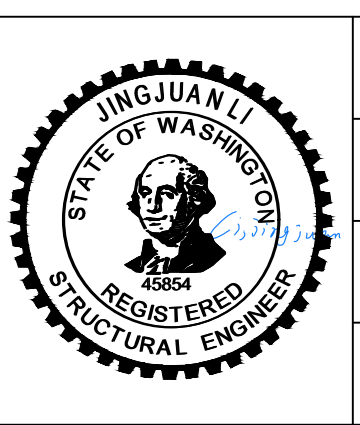

DESIGNED: J. LI	APPROVED: G. FRANCO
DRAWN: T. LOZADA	PROJECT NO: 1127254
CHECKED: G. CHEN	CONTRACT NO:
CHECKED:	



METRO TRANSIT CAPITAL DIVISION
 TROLLEY OVERHEAD SYSTEM
 UNIVERSITY BRIDGE TROLLEY POLE REPLACEMENT

**NORTH END EROSION
 AND SEDIMENT CONTROL PLAN**

DATE: DECEMBER 2, 2025
DRAWING NO: C1.04
SHEET NO. OF 36 43

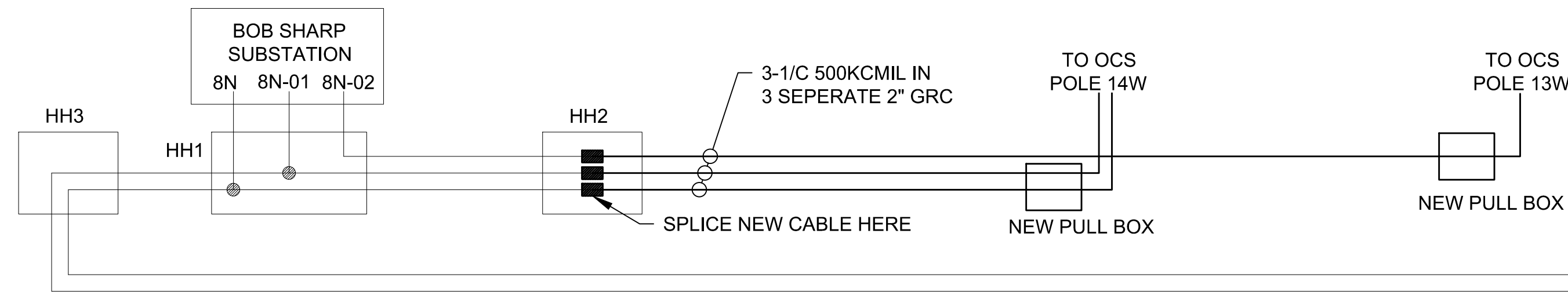
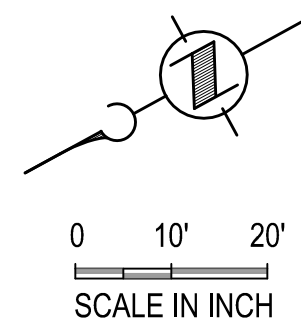

CIRCUIT DIAGRAM

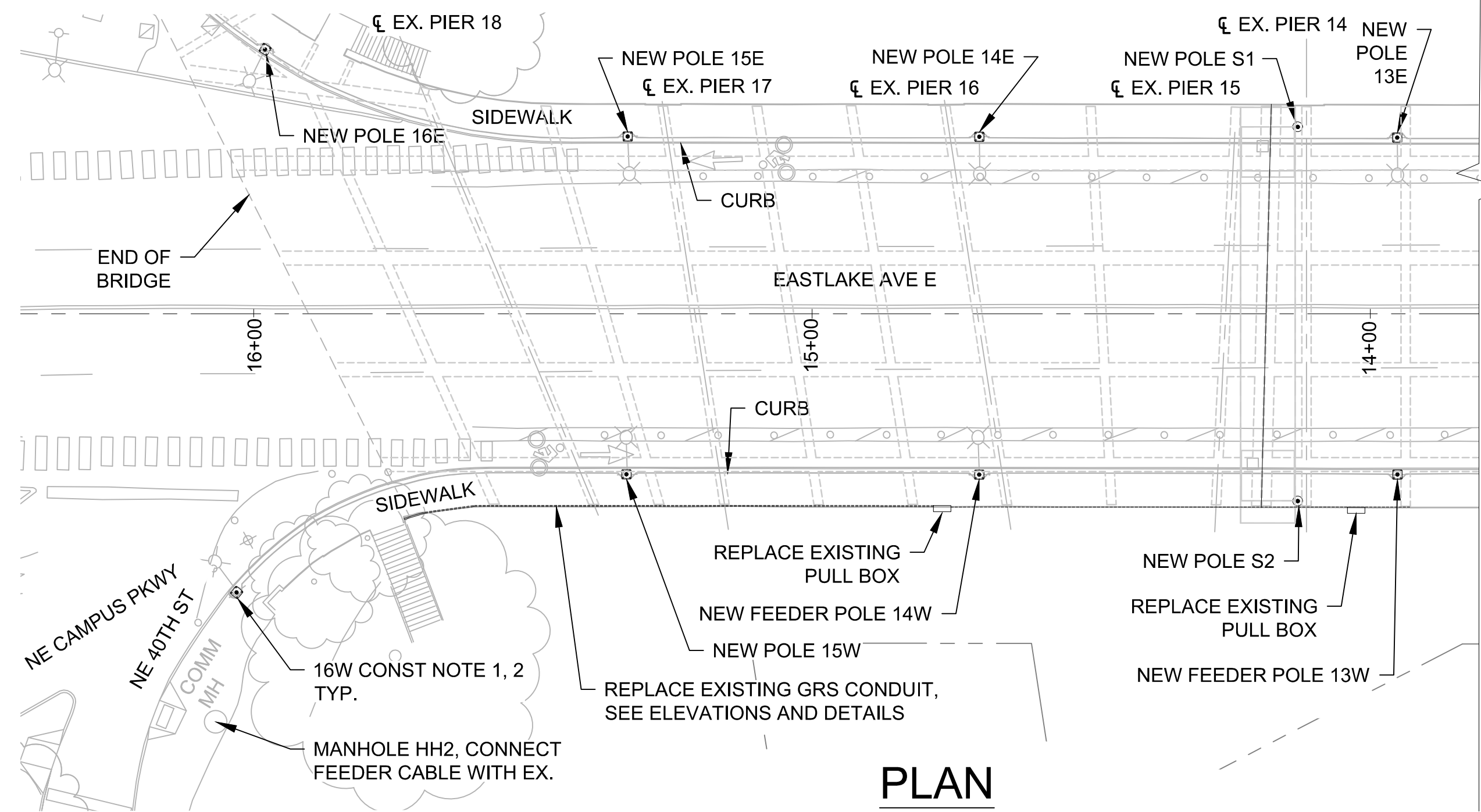

PLAN

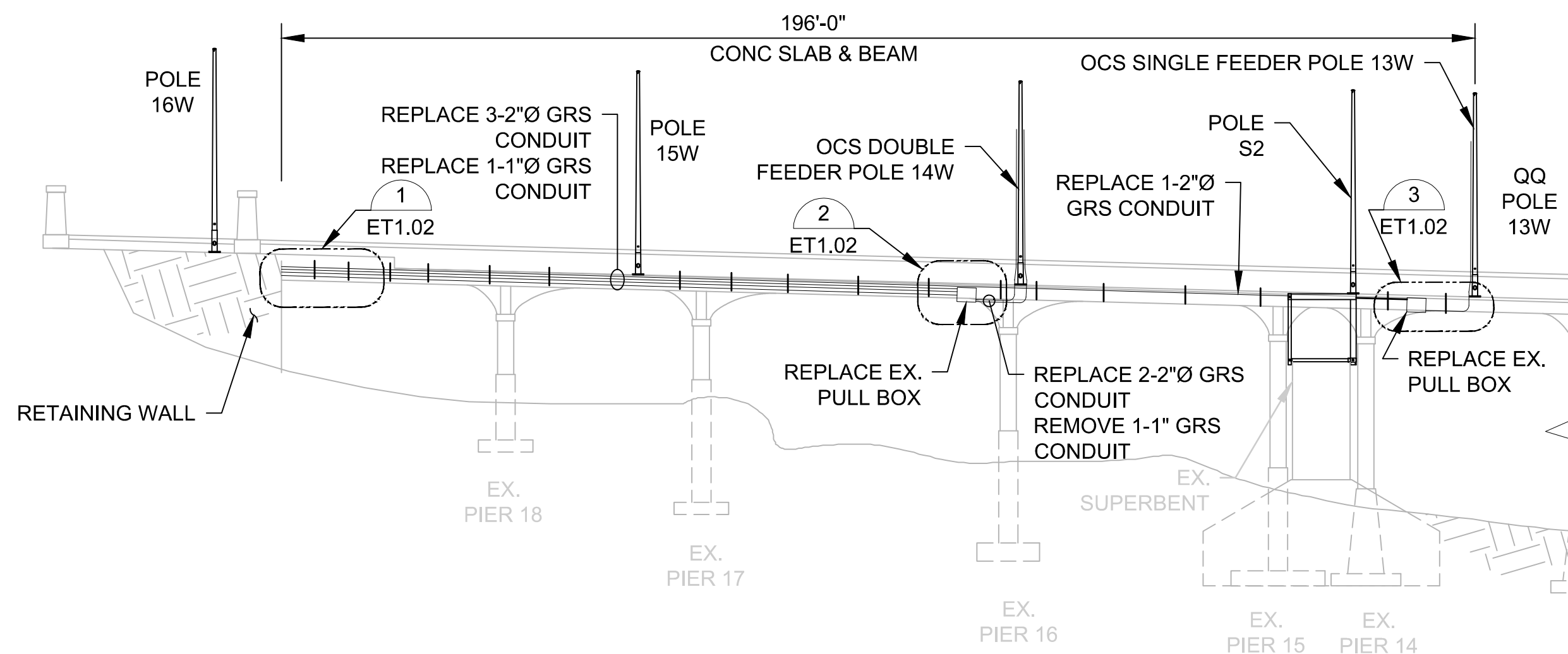
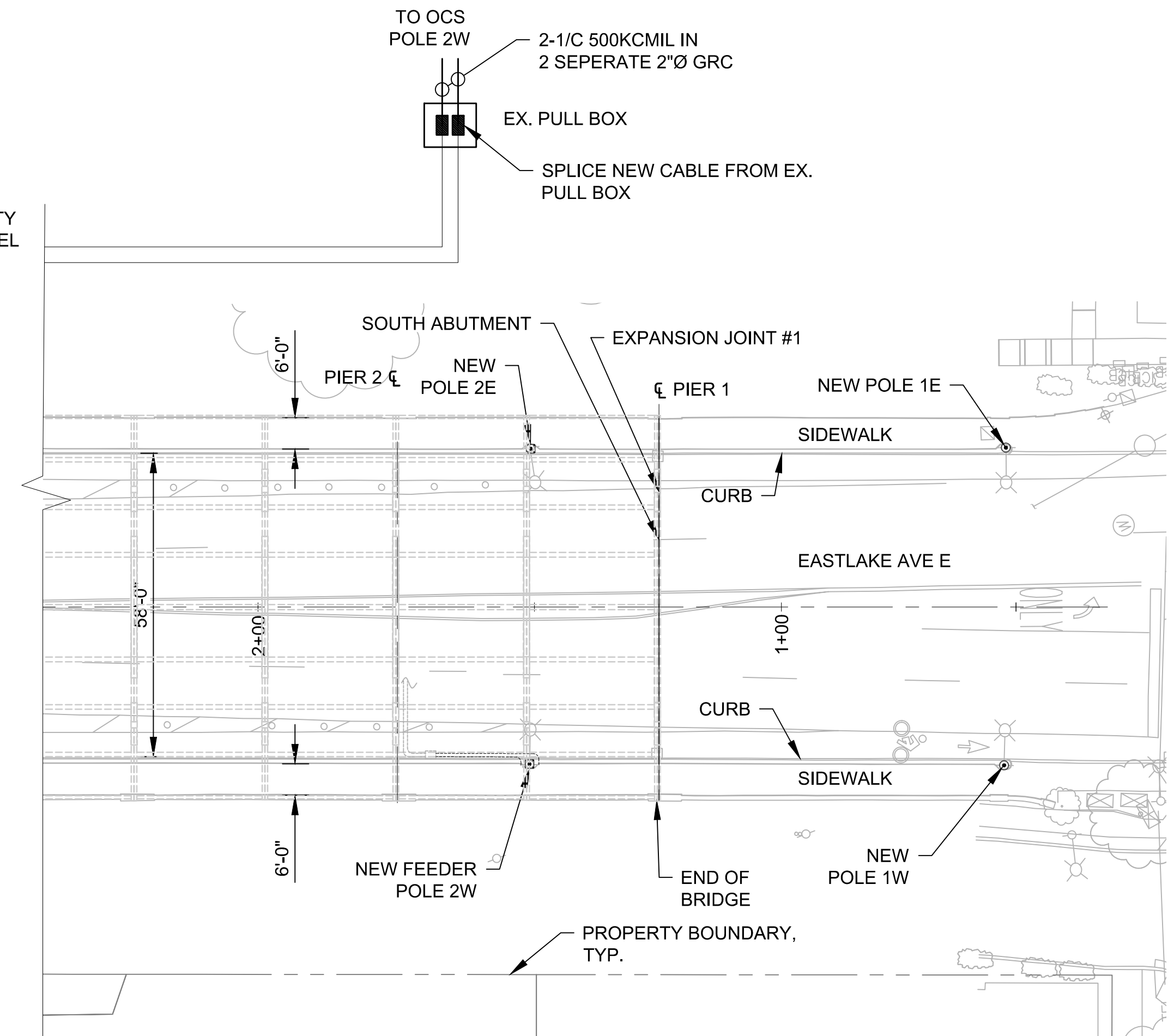

ELEVATION

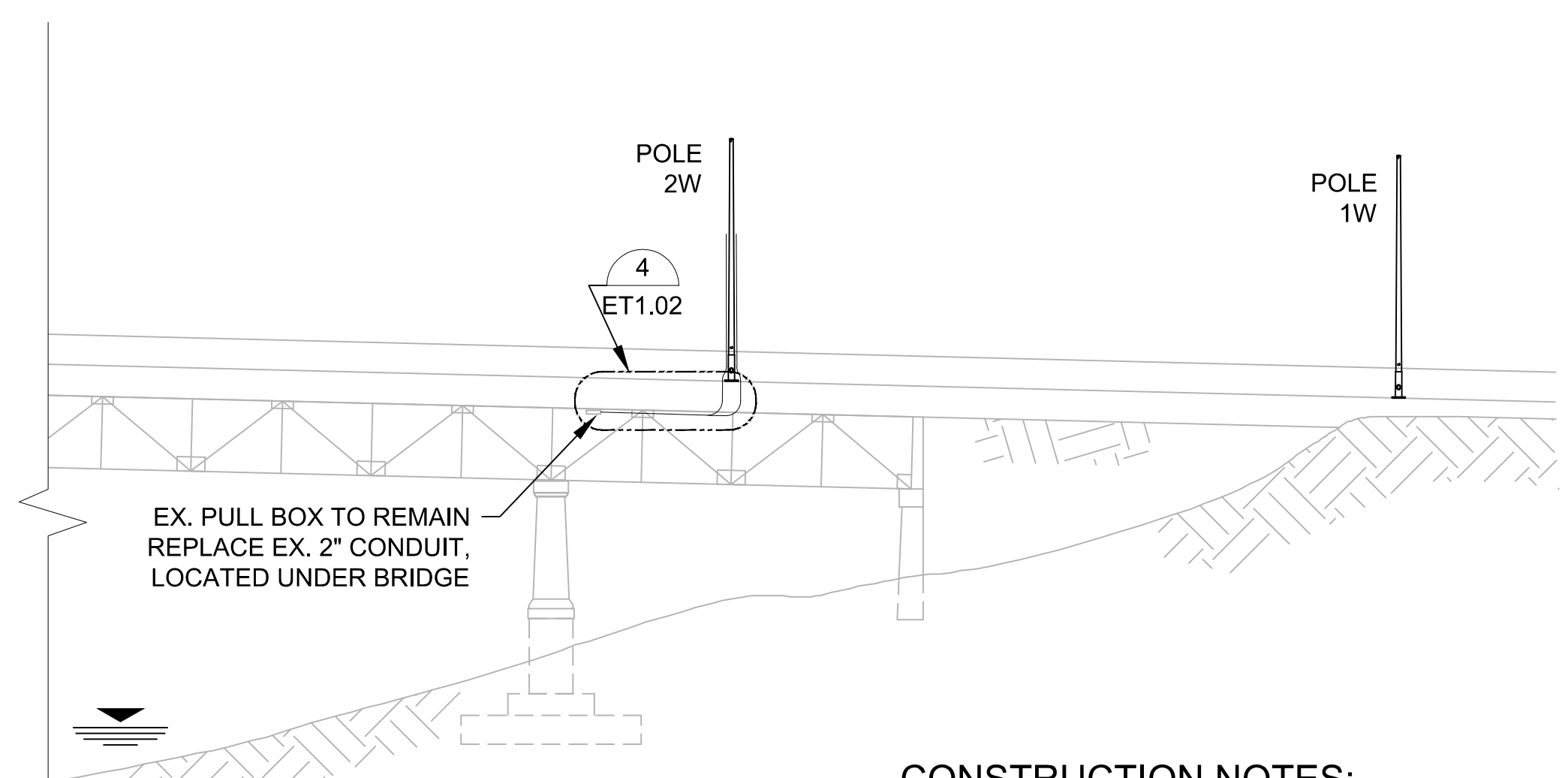

CONSTRUCTION NOTES:

1. REPLACE FEEDER CABLES, CONDUITS AND PULL BOXES AS SHOWN ON DRAWING ET1.02. FEEDER CABLES WILL BE SUPPLIED BY KING COUNTY. CONTRACTOR SHALL PROCURE ALL OTHER PARTS.
2. FIELD VERIFY ALL EXISTING CONDITIONS AND DIMENSIONS. SUBMIT SHOP DRAWINGS FOR CONDUIT ROUTING AND SUPPORT DETAILS BASED ON VERIFIED FIELD CONDITIONS. CONTRACTOR SHALL NOT DAMAGE EXISTING BRIDGE DURING CONSTRUCTION.

Z:\2022\27 KC University Pole Replacement\CADD\SHEET 37 ET1.01 OCS Feeder Span conduit Replacement PLAN.dwg | Layout: ET1.01
 PLOTTED: Dec 05, 2023 04:26:32pm By: Jane Work
 XREFS: KCDCBORR-RHC Engineering Electrical, SHEET 19 ST3.02 Bridge Framing Plan, KCM University Bridge Trolley_2D Basemap
 IMAGES:

No.	REVISION	BY	APPD	DATE

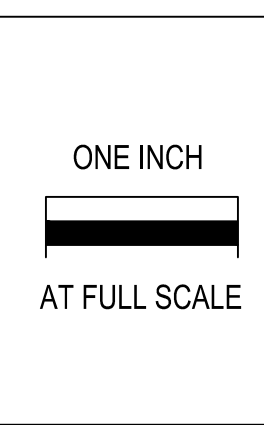

RHC ENGINEERING
 WWW.RHCENGINEERING.COM
 720 3RD AVE SUITE 1400
 SEATTLE WA 98104
 PH: 206.623.5984

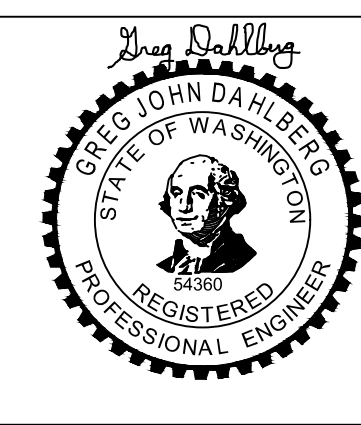

DESIGNED: G. DAHLBERG	APPROVED: G. FRANCO
DRAWN: T. LOZADA	PROJECT NO: 1127254
CHECKED: J. LI	CONTRACT NO:
CHECKED:	



METRO TRANSIT CAPITAL DIVISION
 TROLLEY OVERHEAD SYSTEM
 UNIVERSITY BRIDGE TROLLEY POLE REPLACEMENT

OCS FEEDER SPAN CONDUIT REPLACEMENT PLAN

DATE: DECEMBER 2, 2023
DRAWING NO: ET1.01
SHEET NO. OF 37 43

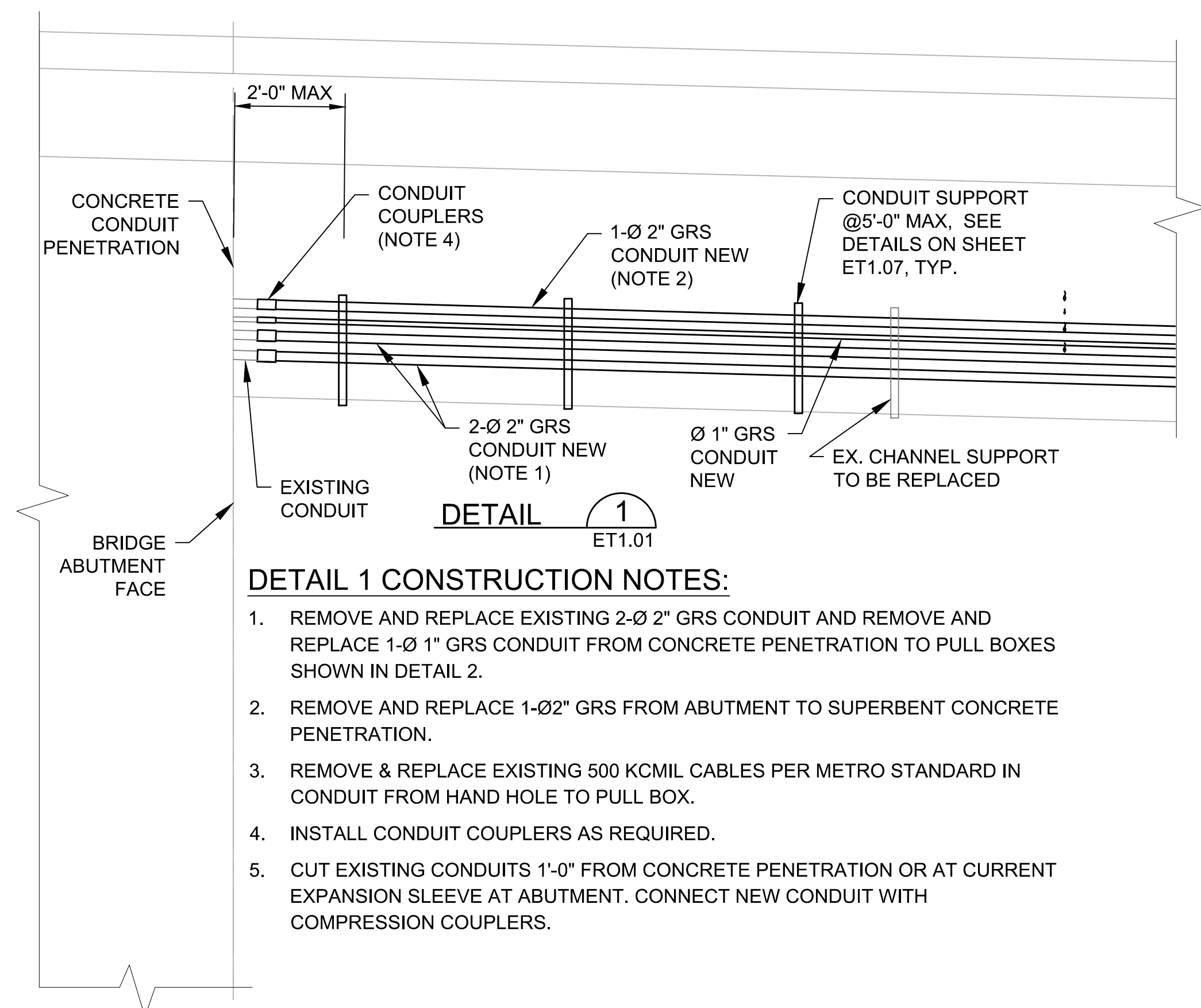

DETAIL 1 CONSTRUCTION NOTES:

1. REMOVE AND REPLACE EXISTING 2-Ø 2" GRS CONDUIT AND REMOVE AND REPLACE 1-Ø 1" GRS CONDUIT FROM CONCRETE PENETRATION TO PULL BOXES SHOWN IN DETAIL 2.
2. REMOVE AND REPLACE 1-Ø 2" GRS FROM ABUTMENT TO SUPERBENT CONCRETE PENETRATION.
3. REMOVE & REPLACE EXISTING 500 KCMIL CABLES PER METRO STANDARD IN CONDUIT FROM HAND HOLE TO PULL BOX.
4. INSTALL CONDUIT COUPLERS AS REQUIRED.
5. CUT EXISTING CONDUITS 1'-0" FROM CONCRETE PENETRATION OR AT CURRENT EXPANSION SLEEVE AT ABUTMENT. CONNECT NEW CONDUIT WITH COMPRESSION COUPLERS.

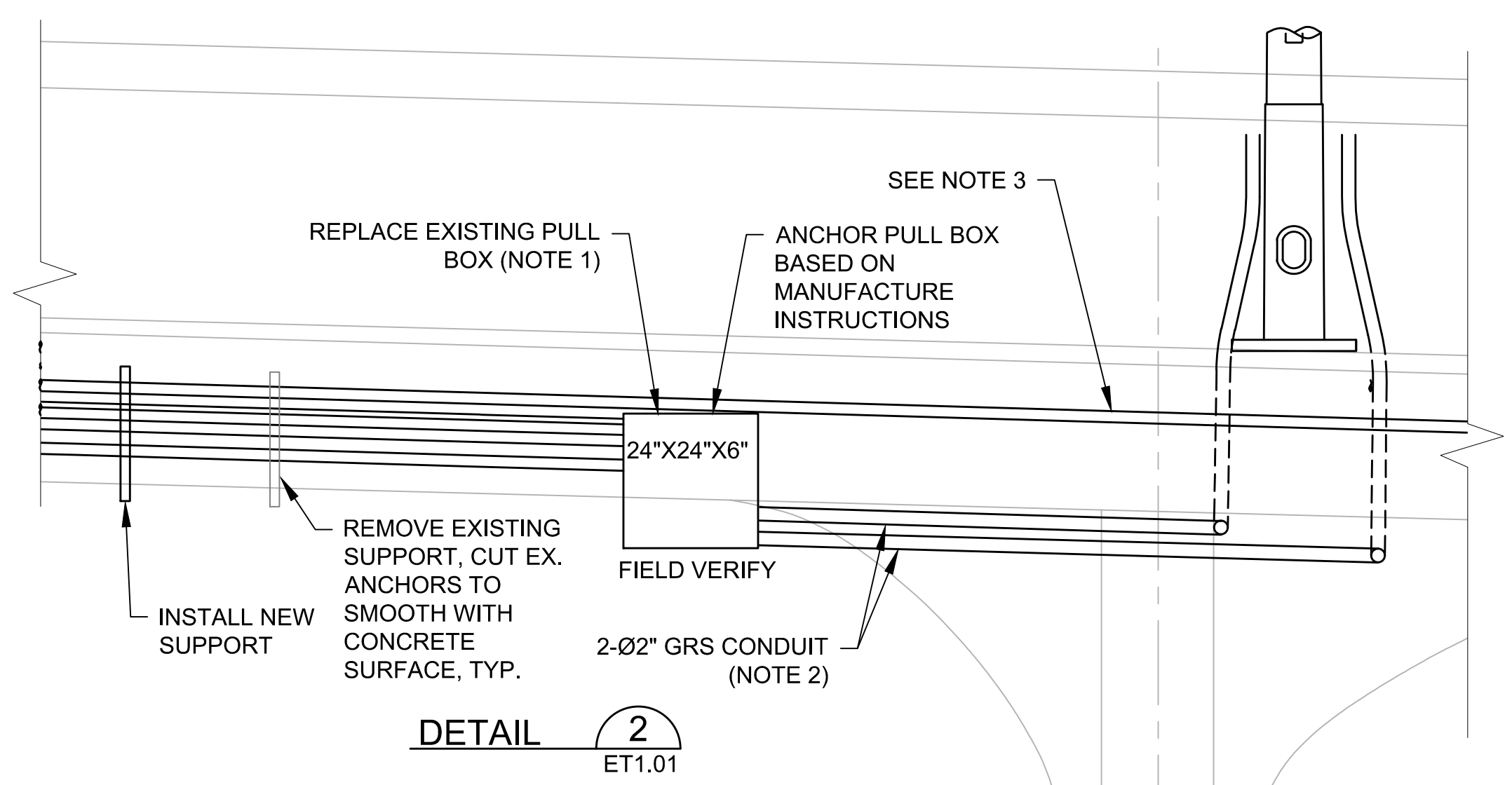

DETAIL 2 CONSTRUCTION NOTES:

1. REMOVE AND REPLACE EXISTING PULL BOX WITH NEMA 4X PULL BOX. REMOVE AND REPLACE EXISTING 500 KCMIL CABLES PER METRO STANDARD IN CONDUIT.
2. REPLACE 2-Ø 2" GRS, AND REMOVE 1-Ø 1" CONDUIT FROM PULL BOX TO FEEDER POLE. STUB UP 2-Ø 2" NEW GRS CONDUIT INTO EX. BRIDGE CONDUIT PENETRATION. REPLACE EXISTING 500 KCMIL CABLES PER METRO STANDARD IN CONDUIT FROM PULL BOX TO FEEDER POLE.
3. REMOVE AND REPLACE 1-Ø 2" GRS FROM SUPERBENT CONCRETE PENETRATION TO NEXT PULL BOX. REPLACE EXISTING 500 KCMIL CABLES PER METRO STANDARD IN CONDUIT FROM HAND HOLE TO NEXT PULL BOX SHOWN IN DETAIL 3.

NOTES:

1. FIELD VERIFY ALL EXISTING CONDITIONS AND DIMENSIONS. NOTIFY ENGINEER PRIOR TO CONSTRUCTION IF ANY DISCREPANCY EXISTS. THE SPECIFIED GRS CONDUIT DIAMETER ARE BASED ON AS-BUILT PLANS. CONTRACTOR TO VERIFY ALL EXISTING GRS CONDUIT SIZE AND MATCH EXISTING.
2. CONTRACTOR SHALL NOT DAMAGE EXISTING BRIDGE DURING CONSTRUCTION. CONTRACTOR SHALL BE FULLY RESPONSIBLE FOR ANY DAMAGE TO THE BRIDGE FROM CONSTRUCTION.
3. METRO STANDARD FEEDER CABLE SHALL BE 500 KCM CU, UNSHIELDED, 2.4 KV EPR W/ PVC JACKET.
4. PAINT CONDUITS AND SUPPORTS GREEN TO MATCH THE COLOR OF NEW POLES.
5. REPLACE ALL EXISTING CONDUIT SUPPORTS. ALL NEW CONDUIT SUPPORTS SHALL BE HOT-DIPPED GALVANIZED STEEL WITH A MAXIMUM SPACING OF 5'-0", ADHESIVE ANCHORS TO EX. CONCRETE SHALL QUALIFY FOR SEISMIC CONDITION. SUBMIT CONDUIT AND PULL BOX SUPPORT PLAN AND DETAILS FOR ENGINEER'S APPROVAL.
6. ALL 2"Ø GRC BENDS SHALL HAVE A MINIMUM BEND RADIUS OF 3'-0" UNLESS SPACE CONSTRAINTS EXIST UNDER THE BRIDGE, IN WHICH CASE SUBJECT TO KING COUNTY PROJECT REPRESENTATIVE APPROVAL.

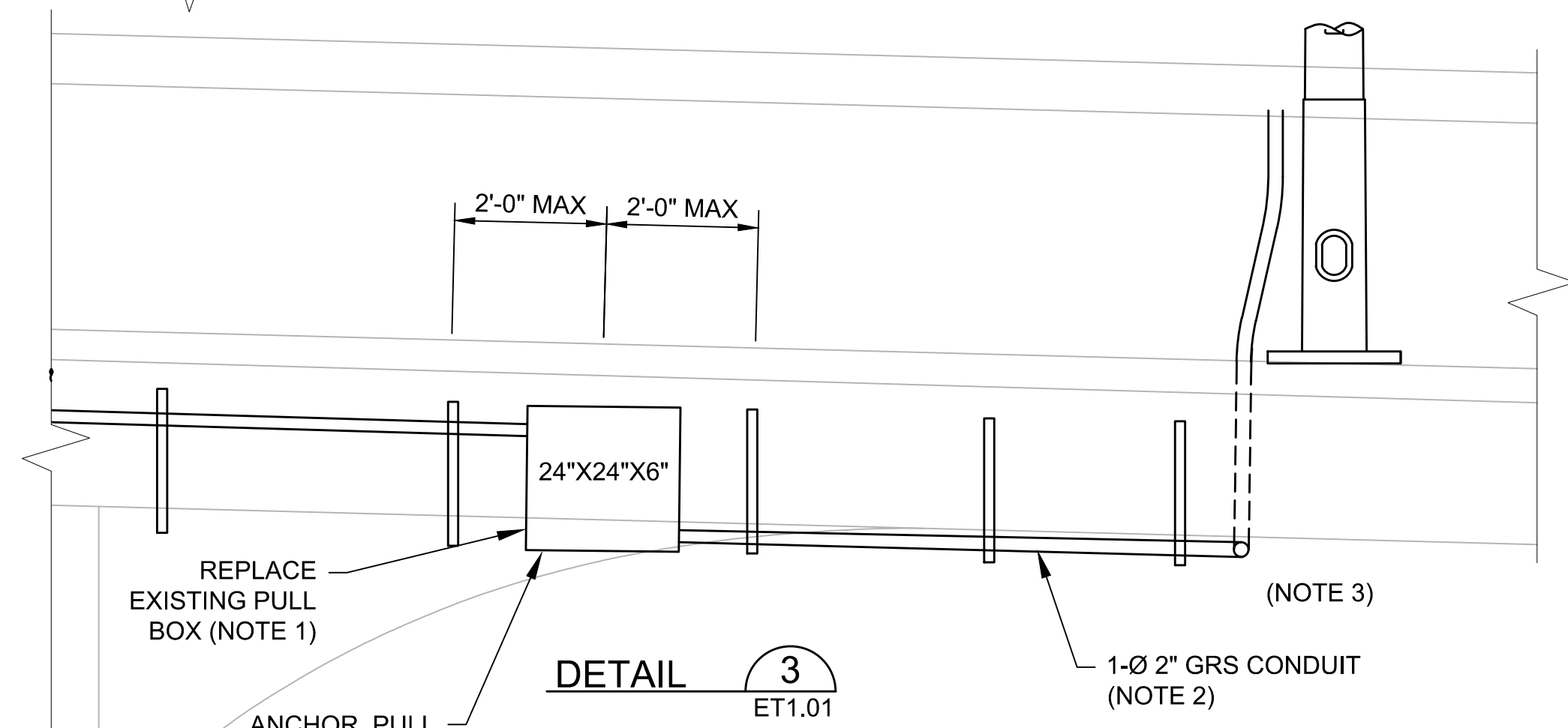

DETAIL 3 CONSTRUCTION NOTES:

1. REMOVE AND REPLACE EXISTING PULL BOX WITH NEMA 4X PULL BOX WITH PIANO HINGED COVER.
2. REMOVE AND REPLACE 1-Ø 2" GRS EXISTING PULL BOX AND STUBBING UP INTO BRIDGE CONDUIT PENETRATION.
3. REMOVE CONDUIT SEGMENT AS SPECIFIED IN SHEET ET1.01. INSTALL AND BEND NEW CONDUIT TO STUB UP THROUGH EX. BRIDGE CONDUIT HOLES. REFILL AND SEAL PENETRATION WITH NON-SHRINK GROUT.
4. REMOVE AND REPLACE EXISTING 500 KCMIL CABLES PER METRO STANDARD IN CONDUIT.

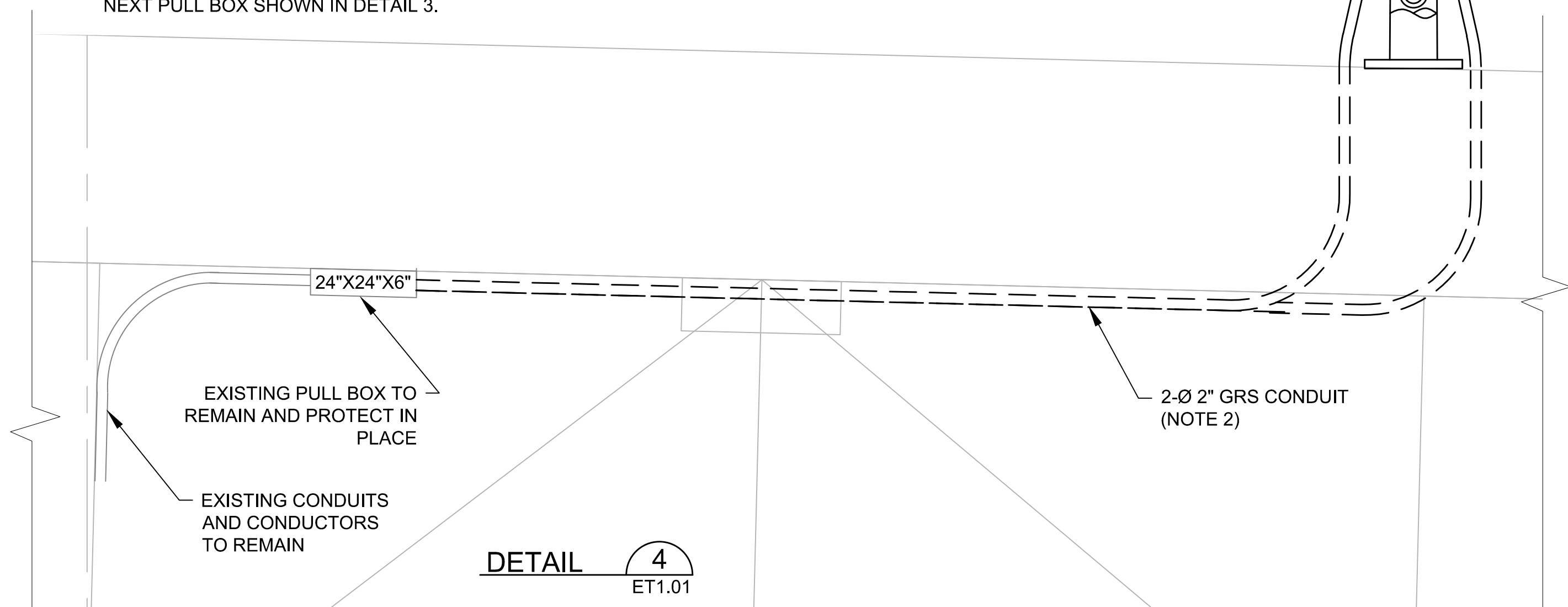

DETAIL 4 CONSTRUCTION NOTES:

1. REMOVE AND REPLACE 2-Ø 2" GRS CONDUIT FROM EX. PULL BOX TO FEEDER POLE. FEEDER CONDUIT BETWEEN SUPPLY AND PULL BOX TO REMAIN.
2. REMOVE AND REPLACE EXISTING 500KCMIL CABLES PER METRO STANDARD IN CONDUIT, SPLICE CABLES IN EX. PULL BOX.

Z:\210127\KC University Pole Replacement\CADD\SHEET 38 ET1.02 Feeder Span Replacement Details.dwg | Layout: ET1.02
 PLOTTED: Jan 02, 2025 09:58:49pm By: Jane Work
 XREFS: KCTDC-BORDER-RHC Engineering IMAGES.

No.	REVISION	BY	APP'D	DATE

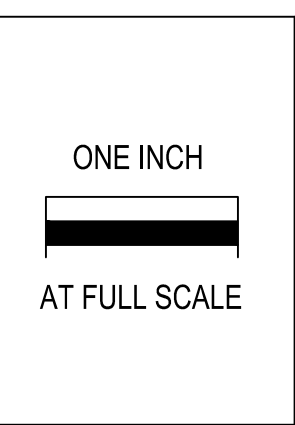

RHC ENGINEERING
 WWW.RHCENGINEERING.COM
 720 3RD AVE SUITE 1400
 SEATTLE WA 98104
 PH: 206.623.5984

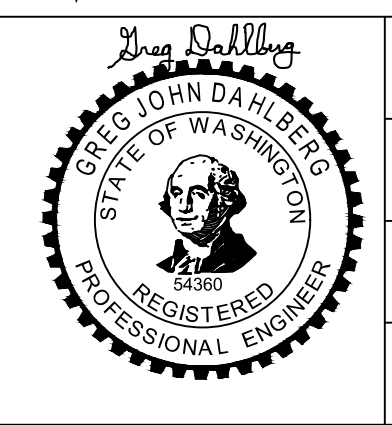

DESIGNED: G. DAHLBERG	APPROVED: G. FRANCO
DRAWN: T. LOZADA	PROJECT NO: 1127254
CHECKED: J. LI	CONTRACT NO: -
CHECKED: -	



METRO TRANSIT CAPITAL DIVISION
 TROLLEY OVERHEAD SYSTEM
 UNIVERSITY BRIDGE TROLLEY POLE REPLACEMENT
OCS FEEDER SPAN CONDUIT REPLACEMENT DETAILS

DATE: DECEMBER 2, 2025
DRAWING NO: ET1.02
SHEET NO. OF 38 43

Z:\2101217\KC University Pole Replacement\CADD\SHEET 40 ET1.04 Street Lighting Conduit Replacement DETAILS.dwg | Layout: E_04
 PLOT: Dec 05, 2024 03:10:00pm By: Jane Wong
 XREFS: KCDCBORDER-RHC Engineering Electrical IMAGES

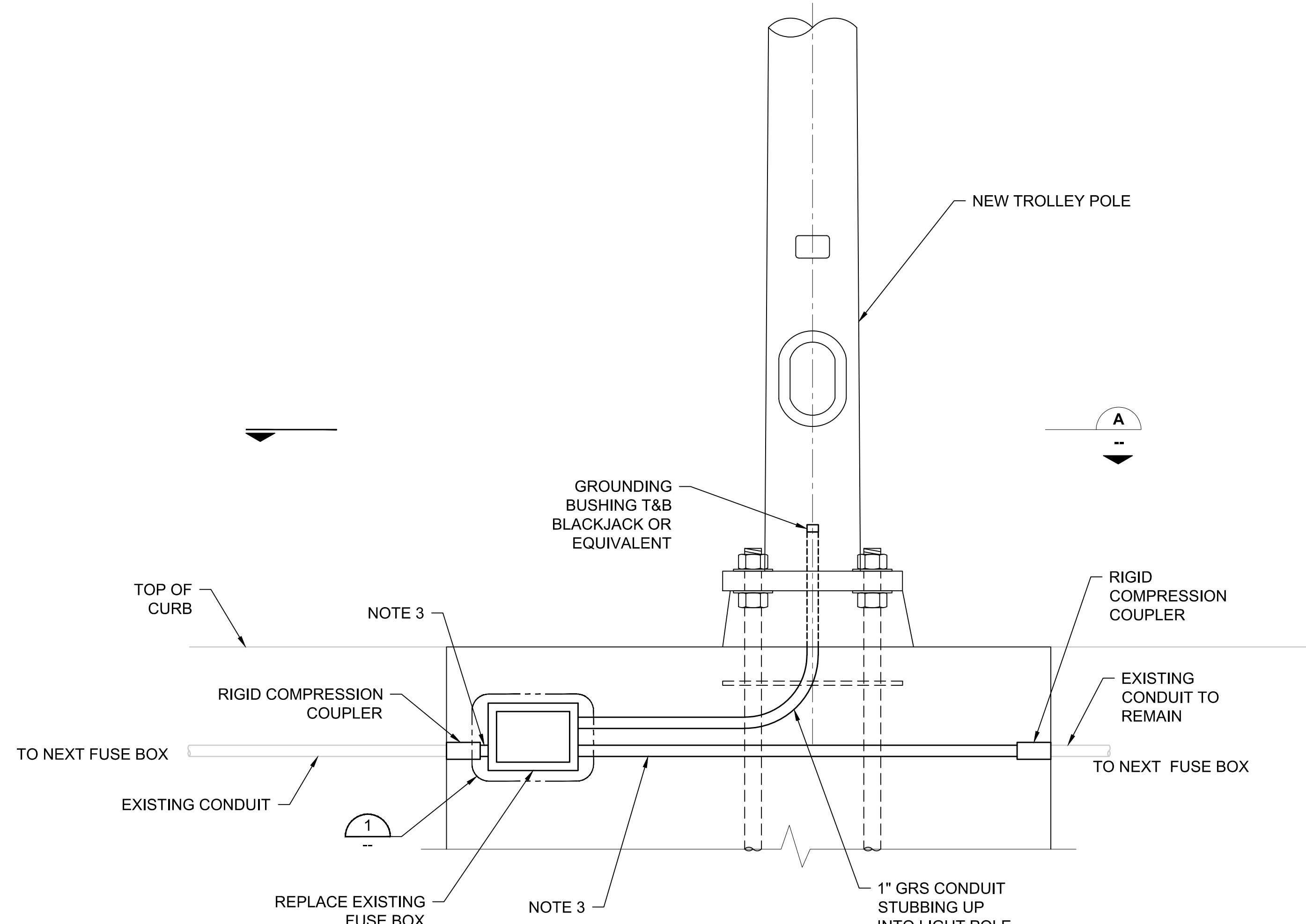

FUSE BOX AND CONDUIT ELEVATION
 NTS

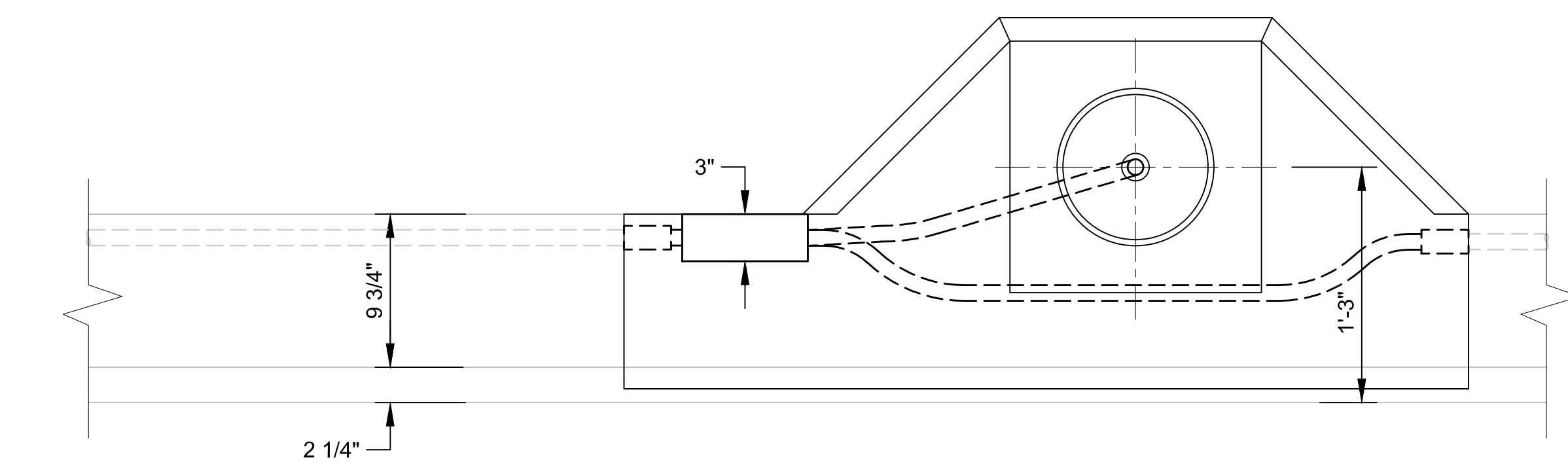

VIEW A
 1 1/2" = 1'-0"

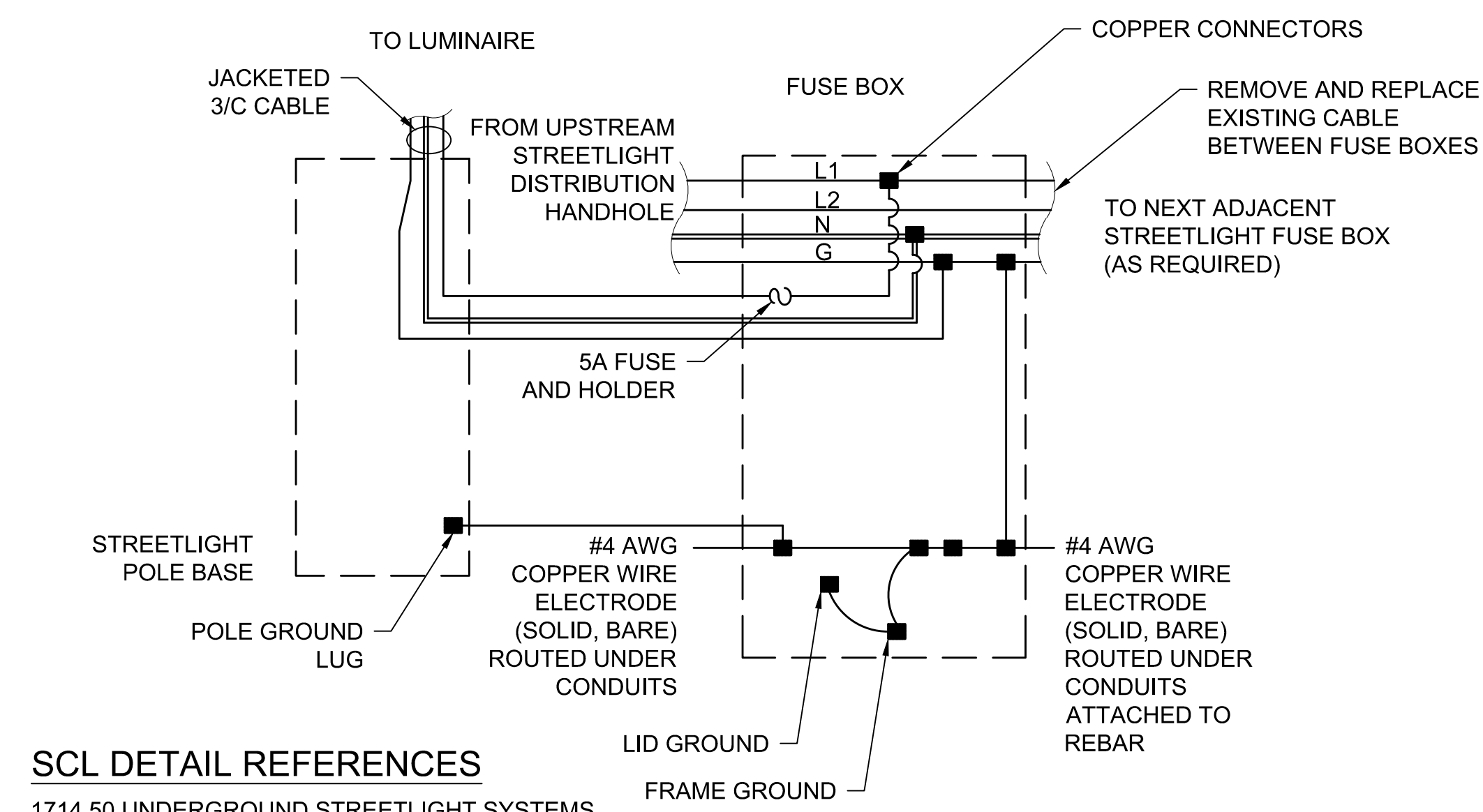

SCL DETAIL REFERENCES

- 1714.50 UNDERGROUND STREETLIGHT SYSTEMS
- 1716.07 STREETLIGHT HANDHOLES AND CONDUITS
- 1730.00 STREETLIGHT FUSING SCHEDULE, INDIVIDUAL
- 6122.35 WIRE, 600V, SINGLE CONDUCTOR, THERMOPLASTIC INSULATED
- 6404.45 CABLE, STREETLIGHT, POLE AND BRACKET, 3/C. 600V
- 6855.55 FUSE, REJECTION-TYPE FAST ACTING, CURRENT LIMITING, 600V
- 6857.05 FUSE HOLDERS

DETAIL A
 FUSE BOX ELECTRICAL PLAN

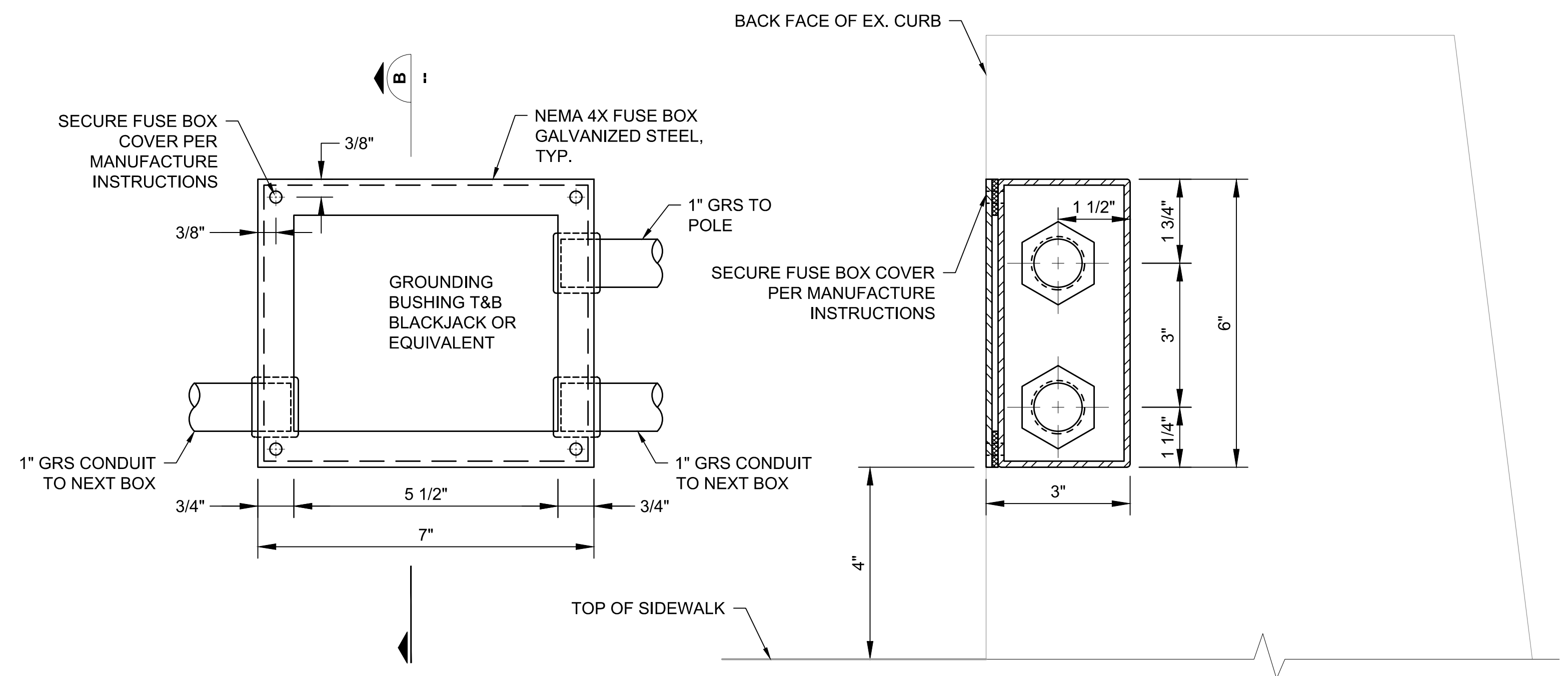

FRONT VIEW COVER REMOVED
 6" = 1'-0"

SECTION B
 6" = 1'-0"

DETAIL 1
 FUSE BOX AT POLES

BILL OF MATERIAL

EQUIPMENT	STOCK NUMBER
COPPER CONNECTORS	013633
5A FUSE	013510
FUSE HOLDER, 600V	682366
15A FUSE	013512
CABLE 3/C, 600V. #12 & #6 AWG	SEE SCL STANDARD NO. 6122.35
FUSE BOX, NEMA 4X	-

* OR APPROVED EQUAL

CONSTRUCTION NOTES:

1. REPLACE EXISTING FUSE BOX.
2. CONDUCTOR L1 AND L2 TO ALTERNATE LIGHTS.
3. REPLACE ANY CONDUIT AND CURBS THAT IS DAMAGED DUE TO THE REMOVAL OF THE EXISTING FUSE BOXES. USE RIGID COMPRESSION COUPLER OR COUPLING TO CONNECT NEW CONDUIT TO UNDAMAGED EXISTING CONDUIT. MATCH NEW CONDUIT SIZE WITH EXISTING CONDUIT. FIELD VERIFY EXISTING CONDUIT SIZES.

No.	REVISION	BY	APP'D	DATE

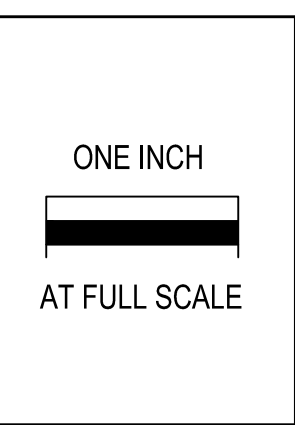

RHC ENGINEERING
 WWW.RHCENGINEERING.COM
 720 3RD AVE SUITE 1400
 SEATTLE WA 98104
 PH: 206.623.5984



DESIGNED: J. LI	APPROVED: G. FRANCO
DRAWN: T. LOZADA	PROJECT NO: 1127254
CHECKED: G. CHEN	CONTRACT NO:



METRO TRANSIT CAPITAL DIVISION
 TROLLEY OVERHEAD SYSTEM
 UNIVERSITY BRIDGE TROLLEY POLE REPLACEMENT

LIGHTING CONDUIT REPLACEMENT DETAILS

DATE: DECEMBER 2, 2025
DRAWING NO: ET1.04
SHEET NO. OF 40 43

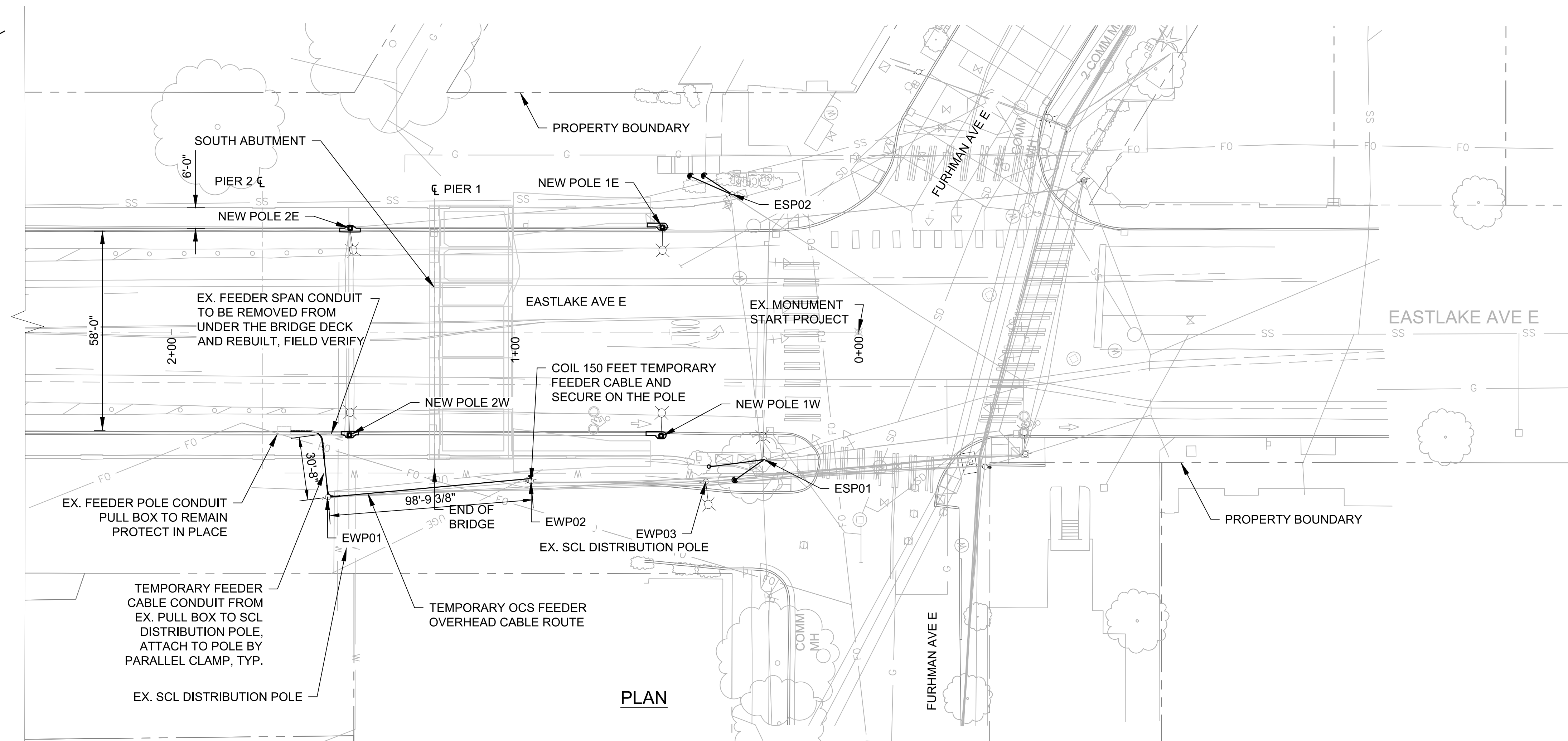
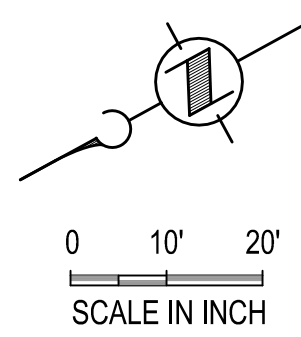

PLAN

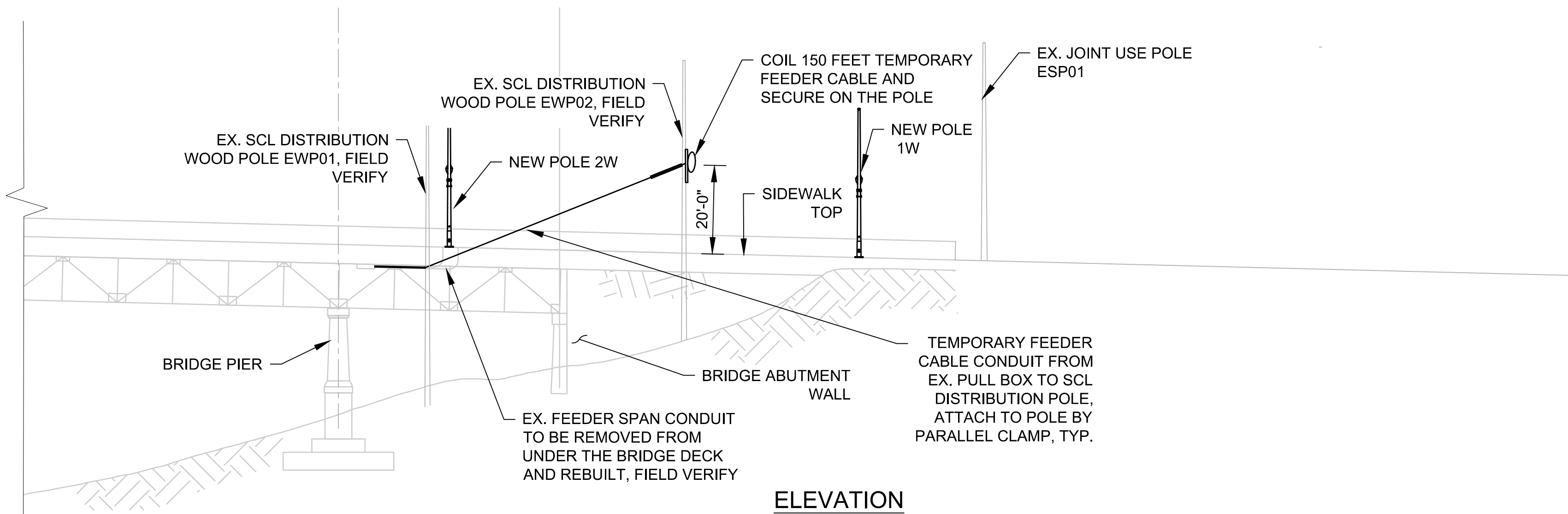

ELEVATION

NOTES:

1. FIELD VERIFY ALL EXISTING CONDITIONS AND GEOMETRIES.
2. TEMPORARY FEEDER CABLE: (1) 500 KCM CU UNSHIELDED 2 KV EPR WITH PVC JACKET
CONDUIT: (1) Φ 2" GRS
3. SEE SHEET ET1.07 FOR FEEDER CABLE AND CONDUIT SUPPORT DETAILS.
4. CONTRACTOR SHALL REMOVE TEMPORARY FEEDER CABLES, POLE GUYS, AND ANCHORS AFTER KING COUNTY RESTORES THE OCS.

Z:\210127\KC University Pole Replacement\CADD\SHEET 41-42 ET1.05-06 OCS Temporary Feeder Span PLAN.dwg Layout: ET1.05
 PLOTTED: Jan 02, 2025 09:43:33pm By: Jane Work
 XREFS: KCM University Bridge Trolley_2D Basemap; KCTDC-BORDER-RHC Engineering Electrical; SHEET 41 ST1.01-ST1.04 PLAN AND ELEVATION; SHEET 8 T3.02 Bridge Framing Plan IMAGES

No.	REVISION	BY	APP'D	DATE

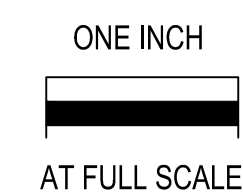

RHC ENGINEERING
 WWW.RHCENGINEERING.COM
 720 3RD AVE SUITE 1400
 SEATTLE WA 98104
 PH: 206.623.5984

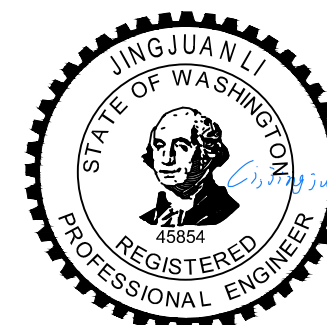

DESIGNED: J. LI	APPROVED: G. FRANCO
DRAWN: T. LOZADA	PROJECT NO: 1127254
CHECKED: G. CHEN	CONTRACT NO:
CHECKED:	



METRO TRANSIT CAPITAL DIVISION
 TROLLEY OVERHEAD SYSTEM
 UNIVERSITY BRIDGE TROLLEY POLE REPLACEMENT

OCS TEMPORARY FEEDER SOUTH END

DATE: DECEMBER 2, 2025
DRAWING NO: ET1.05
SHEET NO. OF 41 43

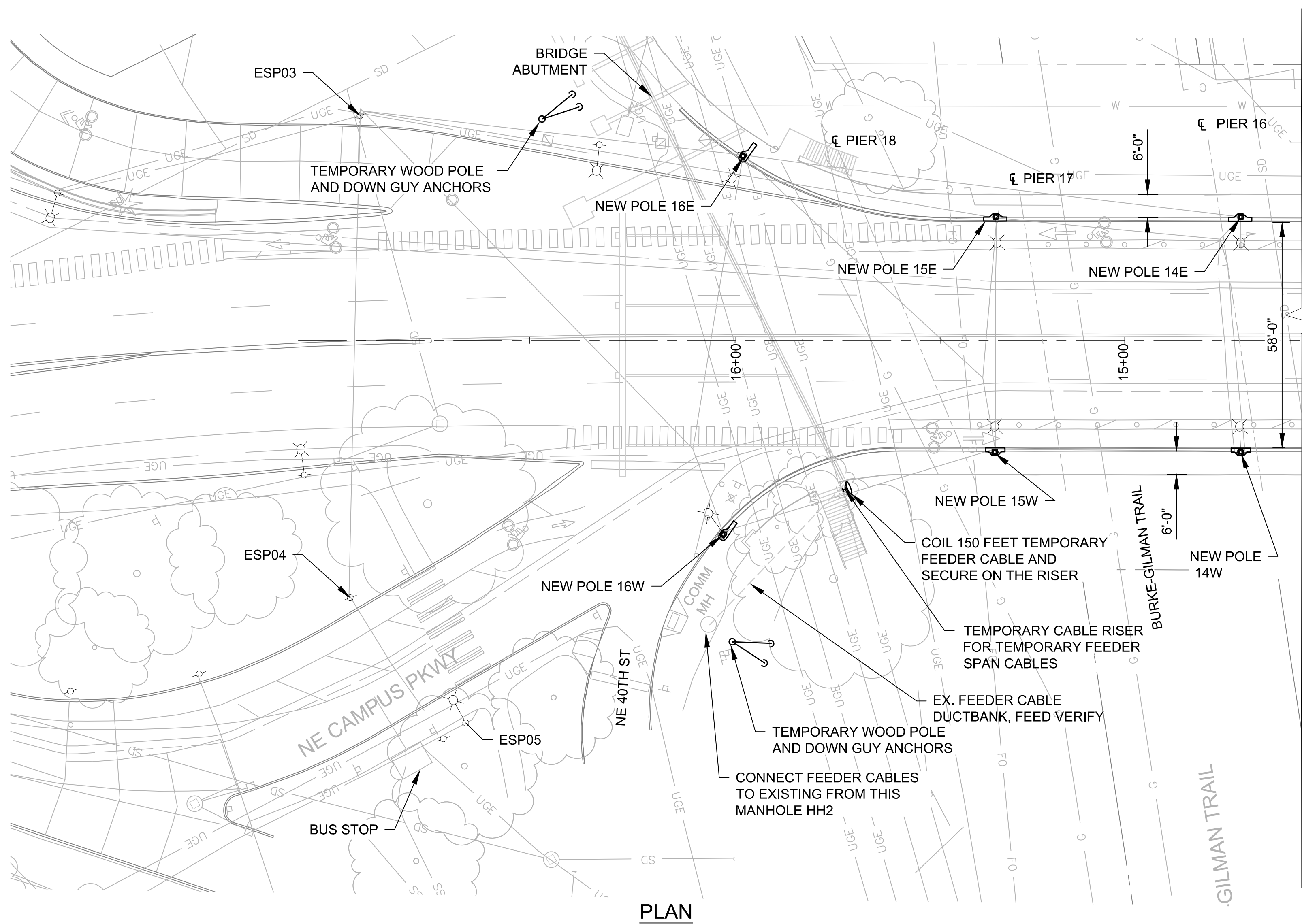
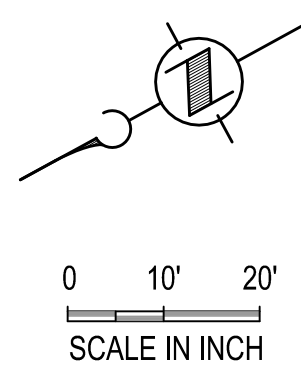

PLAN

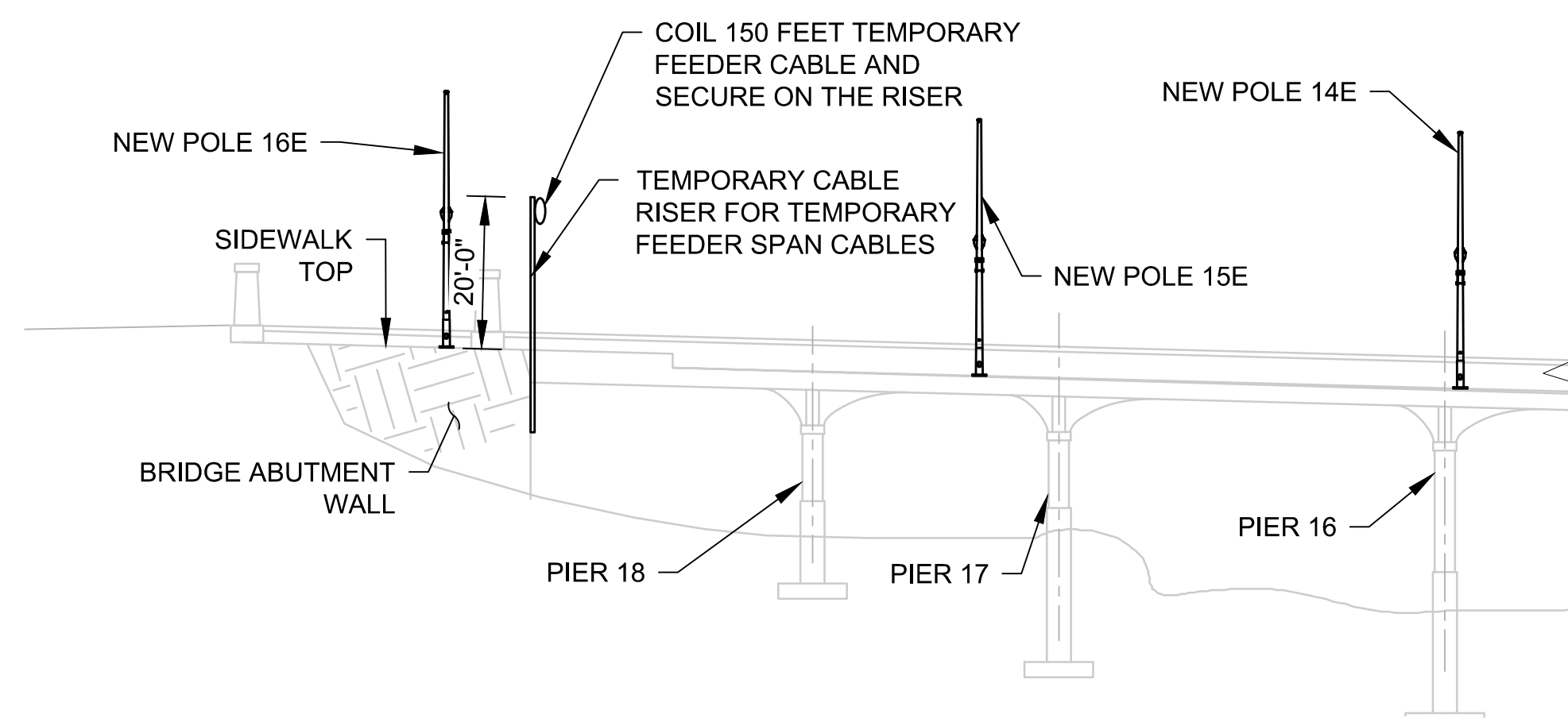

ELEVATION

NOTES:

1. FIELD VERIFY ALL EXISTING CONDITIONS AND GEOMETRIES.
2. CONNECT TEMPORARY FEEDER CABLE FROM EX. MANHOLE AT SIDEWALK. CONNECT TEMPORARY CONDUIT FROM BRIDGE ABUTMENT. SEE SHEET ET1.07 FOR DETAILS.
3. TEMPORARY FEEDER CABLE: (2) 500 KCM CU UNSHIELDED 2 KV EPR WITH PVC JACKET
CONDUIT: (2) Φ2" GRS
4. SEE SHEET ET1.07 FOR FEEDER CABLE AND CONDUIT SUPPORT DETAILS.
5. CONTRACTOR SHALL PROTECT THE INSTALLED FEEDER CABLES FROM DAMAGE OR LOSS PRIOR TO METRO'S WORK.
6. CONTRACTOR SHALL REMOVE TEMPORARY FEEDER CABLES, TEMPORARY WOOD POLES, GUYS, AND ANCHORS AFTER KING COUNTY RESTORES THE OCS. WOOD POLES SHALL BE RETURNED TO KING COUNTY WITHOUT DAMAGE.

Z:\210127\KC University Pole Replacement\CADD\SHEET 41-42 ET1.06-06 OCS Temporary Feeder Span PLAN.dwg | Layout: ET1.06
 PLOTTED: Jan 02, 2025 09:46:39pm By: Jane Work
 XREFS: KCM University Bridge Trolley_2D Basecamp; KCTDC-BORDER-RHC Engineering Electrical; SHEET 41 ST.01-ST1.04 PLAN AND ELEVATION; SHEET 8 T3.02 Bridge Framing Plan IMAGES;

No.	REVISION	BY	APP'D	DATE

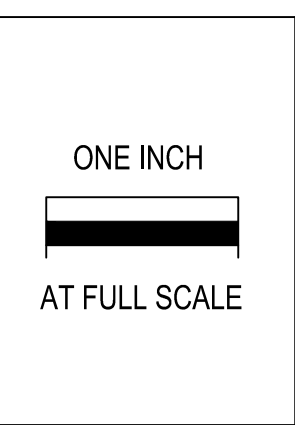

RHC ENGINEERING
 WWW.RHCENGINEERING.COM
 720 3RD AVE SUITE 1400
 SEATTLE WA 98104
 PH: 206.623.5984

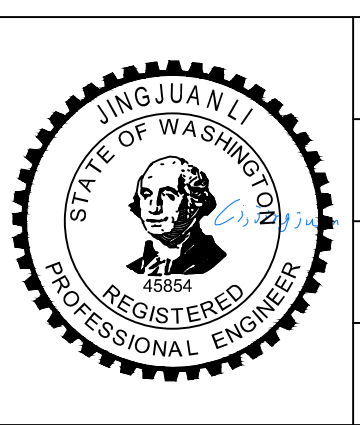

DESIGNED: J. LI	APPROVED: G. FRANCO
DRAWN: T. LOZADA	PROJECT NO: 1127254
CHECKED: G. CHEN	CONTRACT NO: -
CHECKED: -	



METRO TRANSIT CAPITAL DIVISION
 TROLLEY OVERHEAD SYSTEM
 UNIVERSITY BRIDGE TROLLEY POLE REPLACEMENT

**OCS TEMPORARY FEEDER
 NORTH END**

DATE: DECEMBER 2, 2025
DRAWING NO: ET1.06
SHEET NO. OF 42 OF 43

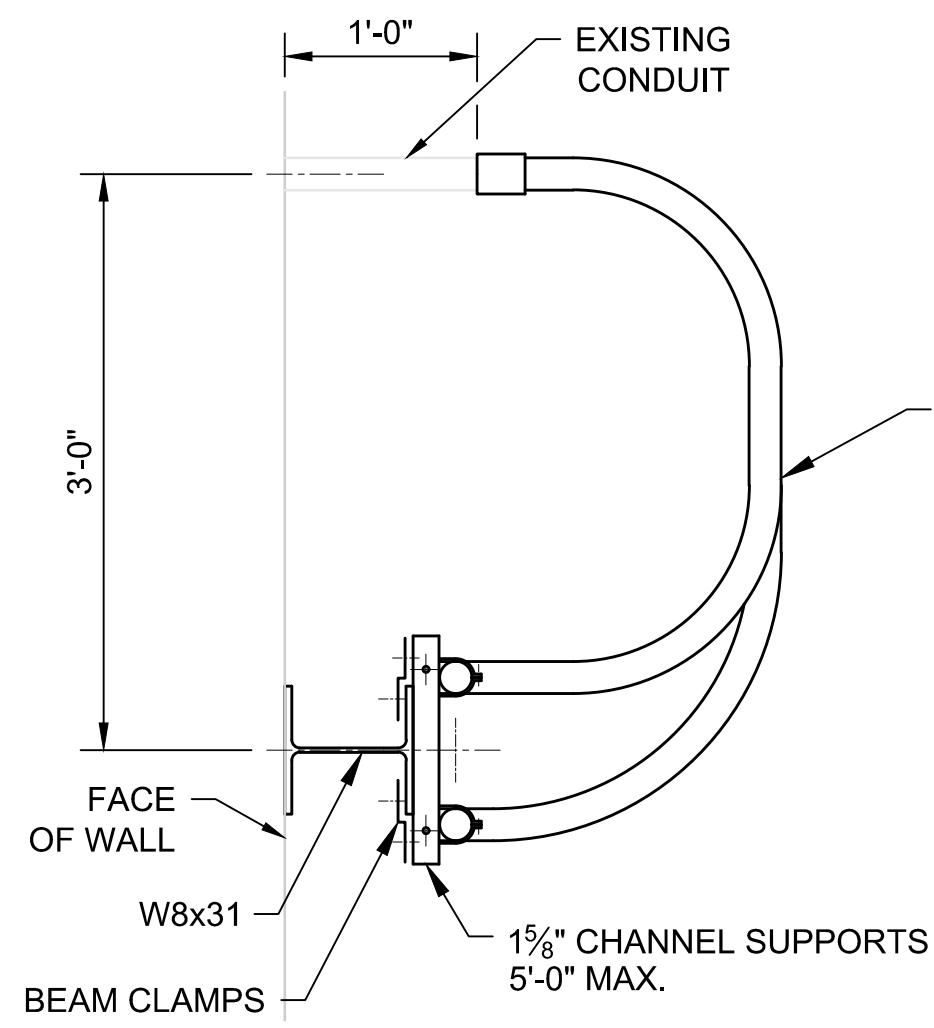

SECTION B
NTS

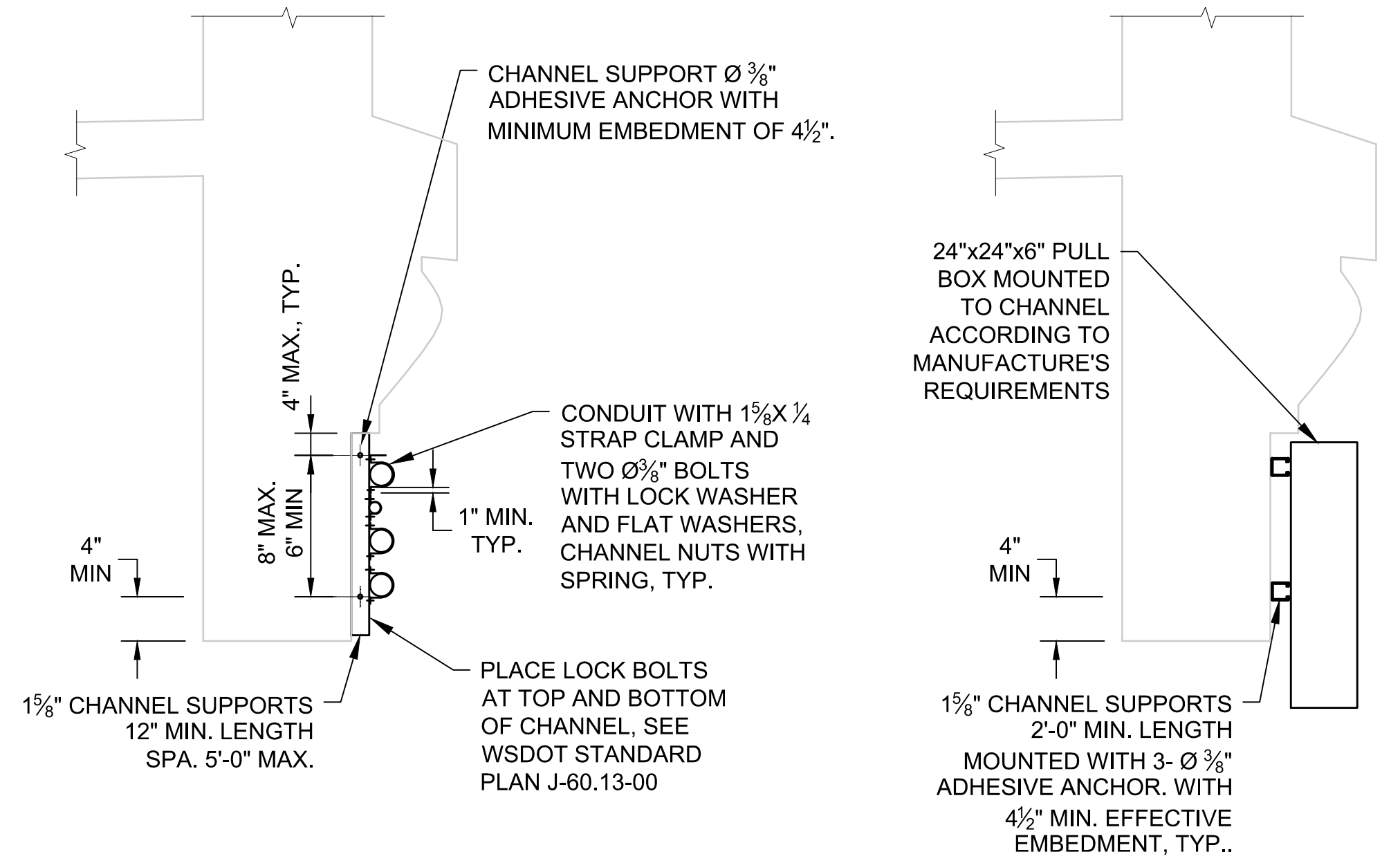

CONDUIT AND PULL BOX MOUNTING DETAIL 1
FEEDER CABLE AT NORTH END
NTS
REFER TO WSDOT STANDARD PLAN J-60.13-00 FOR MORE DETAILS

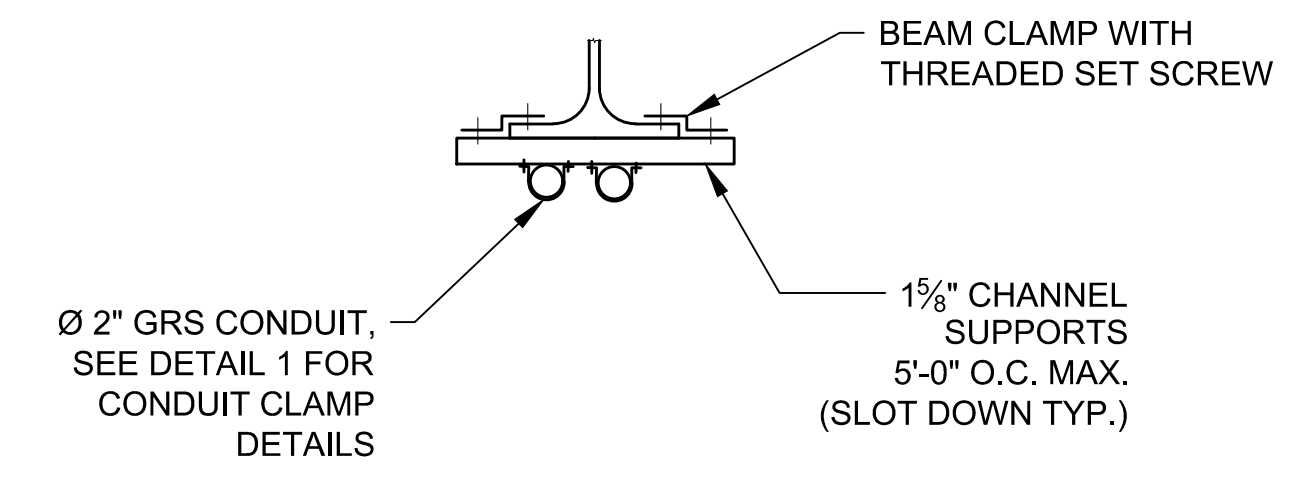

CONDUIT MOUNTING DETAIL 2
FEEDER CABLE UNDER THE BRIDGE AT SOUTH END
NTS

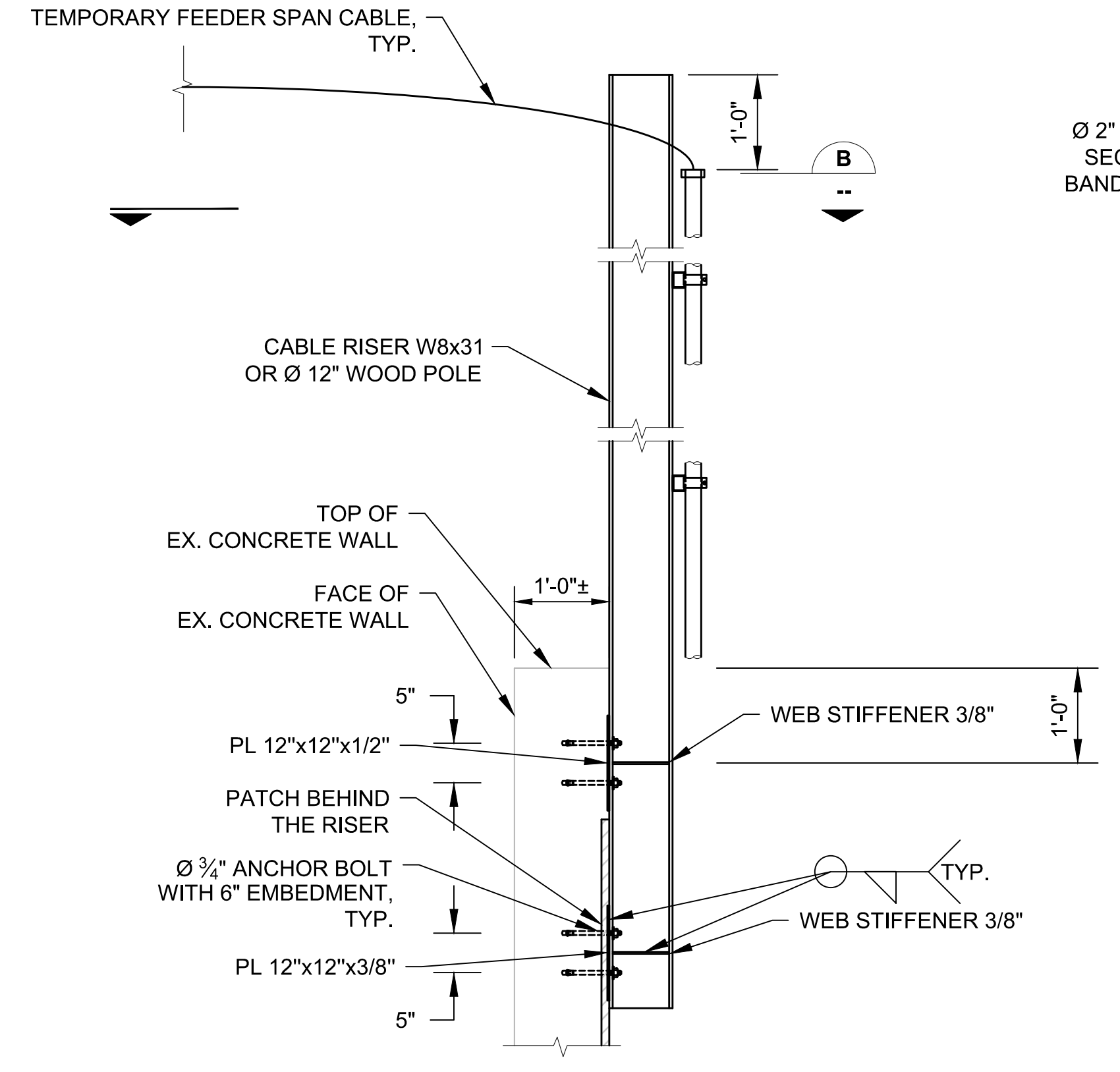

SECTION A
3/4" = 1'-0"

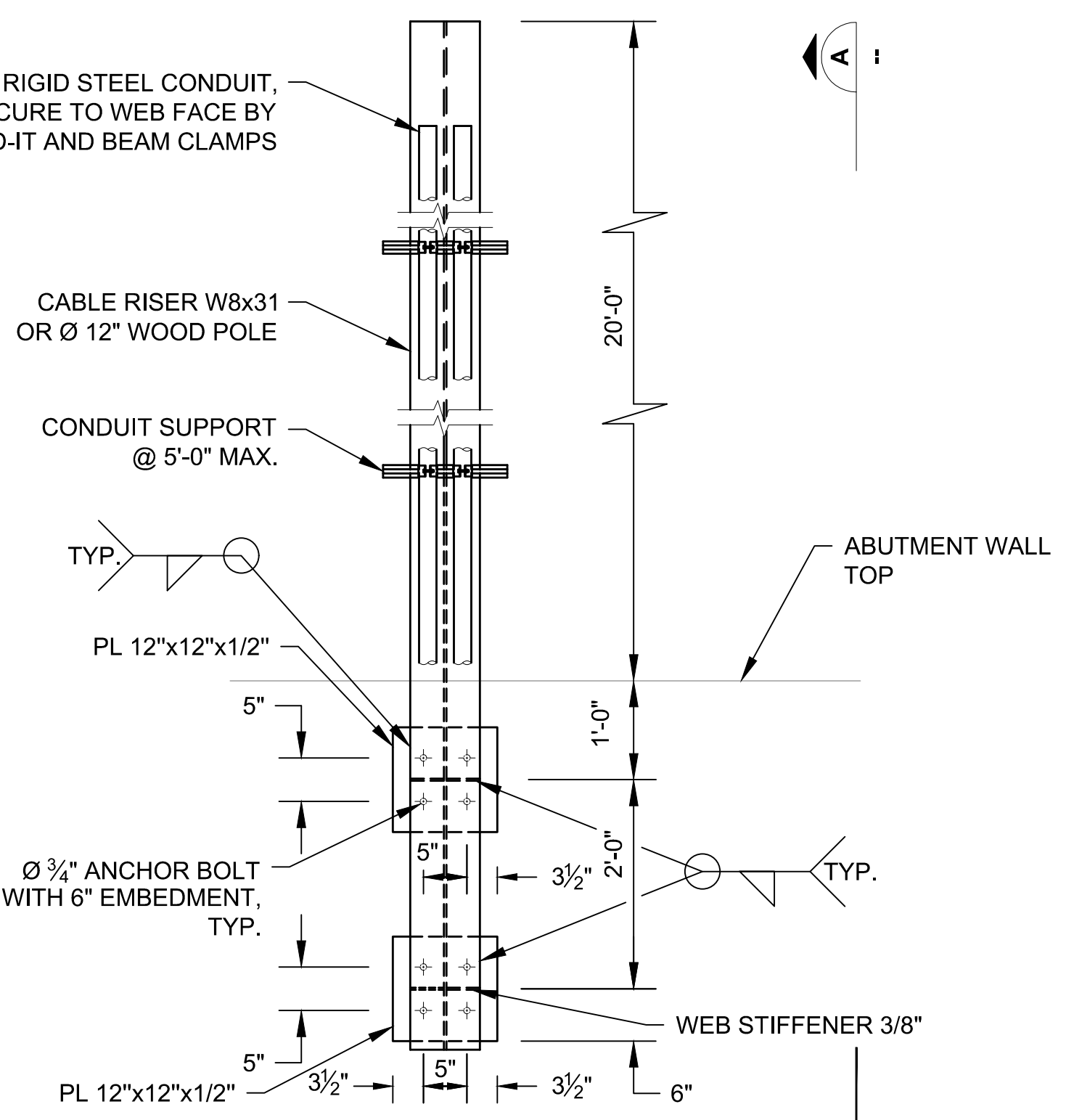

ELEVATION
3/4" = 1'-0"

TEMPORARY CABLE RISER DETAILS
3/4" = 1'-0"

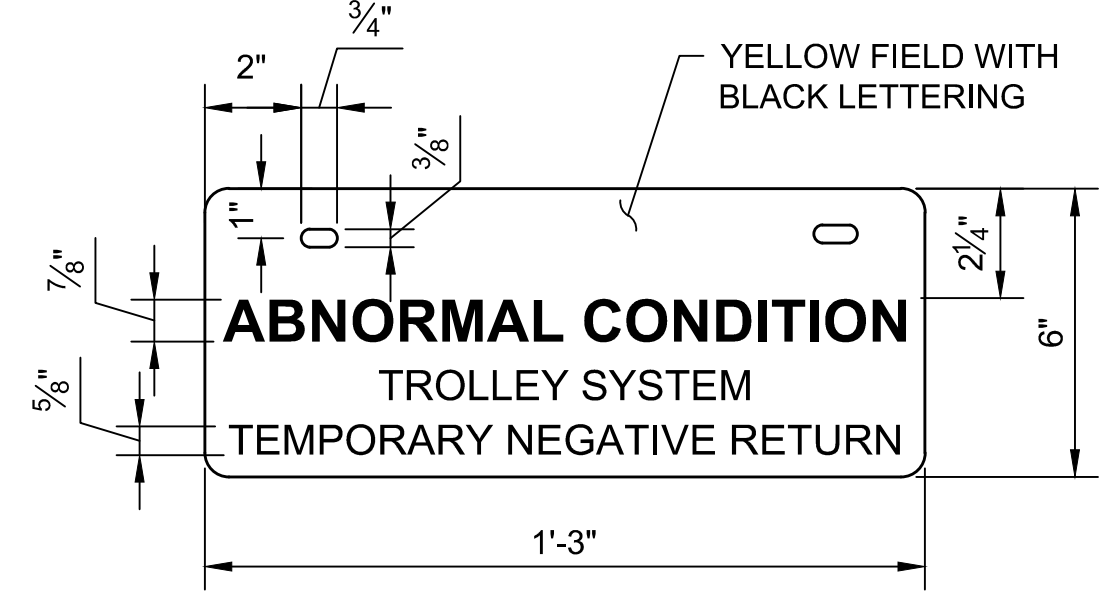

WARNING SIGN
1/8" FIBER GLASS PLATE

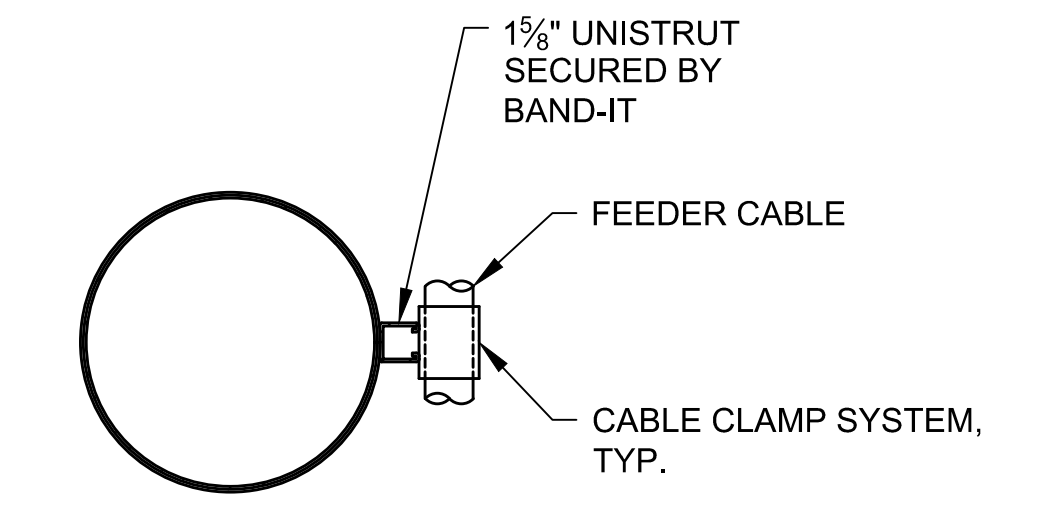

STRAIGHT CABLE SUPPORT
NTS

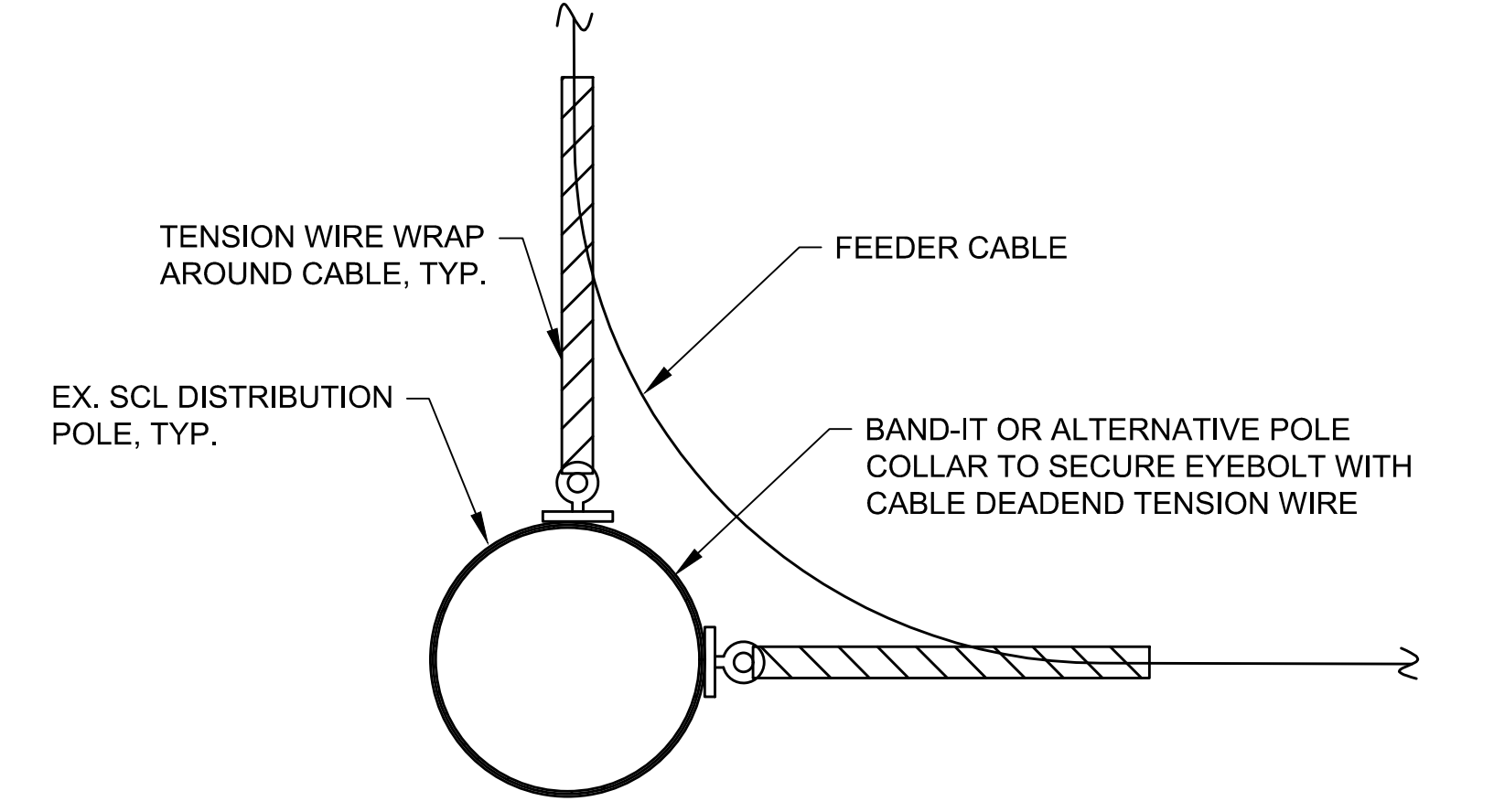

BEND OR END CABLE SUPPORT
NTS

- NOTES:**
1. FIELD VERIFY ALL EXISTING DIMENSIONS AND CONDITIONS.
 2. CONTRACTOR MAY CHOOSE EQUIVALENT ALTERNATIVE TO THE CABLE RISER AND CABLE SUPPORT DETAILS SHOWN IN THIS PLAN, SUBJECT TO ENGINEER'S APPROVAL.
 3. ANCHORS TO EX. CONCRETE SHALL BE QUALIFIED FOR SEISMIC CONDITION.
 4. CONTRACTOR SHALL DELIVER EIGHT(8) WARNING SIGNS TO BE USED ON THE TEMPORARY FEEDER SYSTEM.

7/21/2025 10:07 AM: Project Replacement/CADD/SHEET 10 ETI.07 OCS temporary feeder span details.dwg [Layout: ETI.07] PLOTTED: Dec 11, 2025 12:44:49 pm. By: Jane Work XREFS: KCTDC-ORDER-RHC Engineering IMAGES:

No.	REVISION	BY	APP'D	DATE

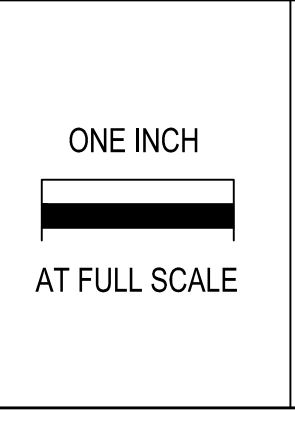

RHC ENGINEERING
 WWW.RHCENGINEERING.COM
 720 3RD AVE SUITE 1400
 SEATTLE WA 98104
 PH: 206.623.5984

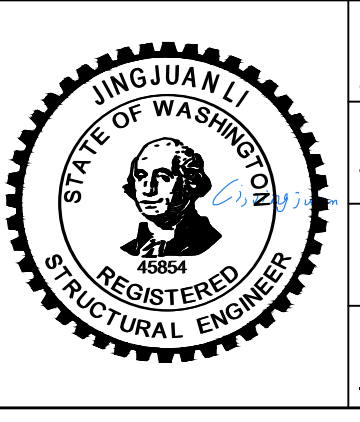

DESIGNED: J. LI	APPROVED: G. FRANCO
DRAWN: T. LOZADA	PROJECT NO: 1127254
CHECKED: G. CHEN	CONTRACT NO: -
CHECKED: -	



METRO TRANSIT CAPITAL DIVISION
 TROLLEY OVERHEAD SYSTEM
 UNIVERSITY BRIDGE TROLLEY POLE REPLACEMENT

**OCS FEEDER
 CABLE SUPPORT DETAILS**

DATE: DECEMBER 2, 2025
DRAWING NO: ET1.07
SHEET NO. OF 43 OF 43